



AUTOMATED DRY ADDITIVE FEEDER

Operators Manual



Software Release: Dry Additive Feeder v1.0

Document: TD-09-06-1020

Revision: D



INTRODUCTION

Thank you for choosing USC, LLC for your equipment needs. We appreciate your business and will work diligently to ensure that you are satisfied with your choice.

OVERVIEW

The purpose of this manual is to provide you with the basic information needed to operate and maintain the Dry Additive Feeder. It does not hold USC, LLC liable for any accidents or injuries that may occur.

The technical information provided in this document is based on extensive testing under controlled conditions at the USC research and development facility.

This information is given without guarantee as the conditions of operation and storage of the equipment are beyond our control. Variables such as temperature, humidity, viscosity of chemical products and changes in seed size or variety may all effect the accuracy of application and seed coverage. Periodically check the equipment calibration while treating and make adjustments as required. This will insure the optimum seed coverage.

OPERATOR RESPONSIBILITIES

As the purchaser/owner/operator of this equipment and control system, you have an obligation to install, operate, and maintain the equipment in a manner that minimizes the exposure of people in your care to any potential hazards inherent in using this equipment. It is critical that the owner of this equipment:

- Has a clear and documented understanding of the process this machine is being used in and of any resulting hazards or special requirements arising from this specific application.
- Allow only properly trained and instructed personnel to install, operate or service this equipment.
- Maintain a comprehensive safety program involving all who work with this machine and other associated process equipment.
- Establish clear areas of staff responsibility (e.g. operation, setup, sanitation, maintenance, and repairs).
- Provide all personnel with necessary safety equipment.
- Periodically inspect the equipment to insure that the doors, covers, guards, and safety devices are in place and functioning, that all safety instructions and warning labels are intact and legible, and that the equipment is in good working order.
- In addition to the operating instructions, observe and enforce the applicable legal and other binding regulations, national and local codes.

DRY ADDITIVE FEEDER

As the person with the most to gain or lose from working safely, it is important that you work responsibly and stay alert. By following a few simple rules, you can prevent an accident that could injure or kill you or a co-worker.

- Disconnect, lockout, and tagout electrical and all other energy sources before inspecting, cleaning, servicing, repairing, or any other activity that would expose you to the hazards of electrical shock.
- Do not operate, clean, or service this equipment until you have read and understood the contents of this manual. If you do not understand the information in this manual, bring it to the attention of your supervisor, or call USC at (785) 431-7900 for assistance.
- Any operator who is known or suspected to be under the influence of alcohol or drugs should not be allowed to operate the equipment.
- Understand and follow the safety practices required by your employer and this manual.
- **PAY ATTENTION** to what you and other personnel are doing and how these activities may affect your safety.
- **Failure to follow these instructions may result in serious personal injury or death.**

RECEIVING YOUR EQUIPMENT

As soon as the equipment is received, it should be carefully inspected to make certain that it has sustained no damage during shipment and that all items listed on the packing list are accounted for. If there is any damage or shortages, the purchaser must immediately notify USC, LLC. Ownership passes to purchaser when the unit leaves the USC, LLC. premises. The purchaser is responsible for unloading and mounting all components of the equipment.

Document the serial number of the machine for future reference. The serialization label is located on the back side of the unit.



SERIAL NUMBER: _____

TABLE OF CONTENTS

<u>Section</u>	<u>Contents</u>	<u>Page #</u>
Section A	Safety Instructions	5
Section B	Installation	14
Section C	Mechanical Operation	18
	System Overview.....	18
	Sprocket Configuration	20
Section D	Electrical Operation.....	22
	Start-up Screen	23
	Main Screen	24
	Recipes Screen	26
	Recipe Editing Screen	27
	Calibration Calculator Screen	28
	Alarms Screen	29
	H-O-A Screen.....	30
	Utilities Screen	31
	Security Screen	32
	Setpoints Screen	33
Section E	Calibration.....	34
Section F	Troubleshooting	36
	Proximity Switch Adjustment Guide	37
Section G	Maintenance.....	38
Section H	Storage.....	40
Section I	Mechanical Drawings	42
Section J	Limited Warranty	69

SAFETY INSTRUCTIONS

SECTION A

Every year accidents in the work place maim, kill, and injure people. Although it may be impossible to prevent all accidents, with the right combination of training, operating practices, safety devices, and operator vigilance, the number of accidents can be significantly reduced. The purpose of this section is to educate equipment users about hazards, unsafe practices, and recommended hazard avoidance techniques.

SAFETY WORDS AND SYMBOLS

It is very important that operators and maintenance personnel understand the words and symbols that are used to communicate safety information. Safety words, their meaning and format, have been standardized for U.S. manufacturers and published by the American National Standards Institute (ANSI). The European Community (E.C.) has adopted a different format based on the International Standards Organization (I.S.O.) and applicable machinery directives. Both formats are presented below. Graphic symbols are not standardized, but most manufacturers will use some variation of the ones seen in this manual.



Indicates an imminently hazardous situation which, if not avoided, **will** result in death or serious injury.



Indicates a potentially hazardous situation which, if not avoided, **could** result in death or serious injury.



Indicates a potentially hazardous situation which, if not avoided, **may** result in minor or moderate injury and/or property damage.



Provides additional information that the operator needs to be aware of to avoid a potentially hazardous situation.



Mandatory Lockout Power Symbol. Disconnect, lockout and tag-out electrical and other energy sources before inspecting, cleaning or performing maintenance on this panel.



International Safety Alert Symbol. The exclamation point (!) surrounded by a yellow triangle indicates that an injury hazard exists. However, it does not indicate the seriousness of potential injury. The exclamation point (!) is also used with the DANGER, WARNING and CAUTION symbols so the potential injury is indicated.



Electrocution Hazard Symbol. This symbol indicates that an electrocution hazard exists. Serious injury or death could result from contacting high voltage.



International Electrocution Hazard. This symbol indicates that an electrocution hazard exists. Serious injury or death could result from contacting high voltage.



Mandatory Read Manual Action Symbol. (I.S.O. format) This symbol instructs personnel to read the Operators Manual before servicing or operating the equipment.



Mandatory Read Manual Action Symbol. This symbol instructs personnel to read the Operators Manual before servicing or operating the equipment.

NOTICE

Notice is used to notify people of important installation, operation or maintenance information which is not hazard related.

LOCKOUT / TAGOUT PROCEDURES

Lockout/Tagout is the placement of a lock/tag on an energy isolating device in accordance with an established procedure. When taking equipment out of service to perform maintenance or repair work, always follow the lockout/tagout procedures as outlined in ANSI Z344.1 and/or OSHA Standard 1910.147. This standard “requires employers to establish a program and utilize procedures for affixing appropriate lockout devices or tagout devices to energy isolating devices and to otherwise disable machines or equipment to prevent unexpected energizing, start-up, or release of stored energy in order to prevent injury to employees.”

HAZARD REVIEW



Electrocution Hazard

Electrocution accidents are most likely to occur during maintenance of the electrical system or when working on or near exposed high voltage wiring. This hazard does not exist when the electrical power has been disconnected, properly locked, and tagged out.



Automatic Start Hazard

This equipment may be controlled by an automated system and may start without warning. Failure to properly disconnect, lockout, and tagout all energy sources of remotely controlled equipment creates a very hazardous situation and could cause injury or even death. PLEASE STAY CLEAR AND BE ALERT.

YOU are responsible for the **SAFE** operation and maintenance of your USC, LLC equipment . **YOU** must ensure that you and anyone else who is going to operate, maintain or work around the equipment be familiar with the operating and maintenance procedures and related **SAFETY** information contained in this manual. This manual will take you step-by-step through your working day and alert you to good safety practices that should be adhered to while operating the equipment

Remember, **YOU** are the key to safety. Good safety practices not only protect you, but also the people around you. Make these practices a working part of your safety program. Be certain that **EVERYONE** operating this equipment is familiar with the recommended operating and maintenance procedures and follows all the safety precautions. Most accidents can be prevented. Do not risk injury or death by ignoring good safety practices.

- Equipment owners must give operating instructions to operators or employees before allowing them to operate the machine, and at least annually thereafter per OSHA (Occupational Safety and Health Administration) regulation 1928.57.
- The most important safety device on this equipment is a **SAFE** operator. It is the operator's responsibility to read and understand **ALL** Safety and Operating instructions in the manual and to follow them. All accidents can be avoided.
- A person who has not read and understood all operating and safety instructions is not qualified to operate the machine. An untrained operator exposes himself and bystanders to possible serious injury or death.
- Do not modify the equipment in any way. Unauthorized modification may impair the function and/or safety and could affect the life of the equipment.
- Think SAFETY! Work SAFELY!

GENERAL SAFETY

1. Read and understand the operator's manual and all safety labels before operating, maintaining, adjusting or unplugging the equipment .
2. Only trained persons shall operate the equipment . An untrained operator is not qualified to operate the machine.
3. Have a first-aid kit available for use should the need arise, and know how to use it.



DRY ADDITIVE FEEDER

4. Provide a fire extinguisher for use in case of an accident. Store in a highly visible place.
5. Do not allow children, spectators or bystanders within hazard area of machine.
6. Wear appropriate protective gear. This includes but is not limited to:
 - A hard hat
 - Protective shoes with slip resistant soles
 - Protective goggles
 - Heavy gloves
 - Hearing protection
 - Respirator or filter mask
7. Place all controls in neutral or off, stop motor, and wait for all moving parts to stop. Then disable power source before servicing, adjusting, repairing, or unplugging.
8. Review safety related items annually with all personnel who will be operating or maintaining the equipment.



OPERATING SAFETY:

1. Read and understand the operator's manual and all safety labels before using.
2. Disconnect and disable electrical supply completely and wait for all moving parts to stop before servicing, adjusting, repairing or unplugging.
3. Clear the area of bystanders, especially children, before starting.
4. Be familiar with the machine hazard area. If anyone enters hazard area, shut down machine immediately. Clear the area before restarting.
5. Keep hands, feet, hair and clothing away from all moving and/or rotating parts.
6. Stay away from overhead obstructions and power lines during operation and transporting. Electrocution can occur without direct contact.
7. Do not operate machine when any guards are removed.
8. Inspect welds and repair if needed.

PLACEMENT SAFETY

1. Move only with the appropriate equipment
2. Stay away from overhead power lines when moving equipment. Electrocutation can occur without direct contact.
3. Be familiar with machine hazard area. If anyone enters hazard areas, shut down machine immediately. Clear the area before restarting.
4. Operate the equipment on level ground free of debris. Anchor the equipment to prevent tipping or upending.



Before placement of the equipment, be sure that ground is reasonably level. The equipment may topple or work improperly if the ground is too uneven, damaging the equipment and/or causing personal injury.

MAINTENANCE SAFETY

1. Review the operator's manual and all safety items before working with, maintaining or operating the equipment.
2. Place all controls in neutral or off, stop motors, disable power source, and wait for all moving parts to stop before servicing, adjusting, repairing or unplugging.
3. Follow good shop practices:
Keep service area clean and dry.
Be sure electrical outlets and tools are properly grounded.
Use adequate light for the job at hand.
4. Keep hands, feet, hair and clothing away from all moving and/or rotating parts.
5. Clear the area of bystanders, especially children, when carrying out any maintenance and repairs or making any adjustments.
6. Before resuming work, install and secure all guards when maintenance work is completed.
7. Keep safety labels clean. Replace any sign that is damaged or not clearly visible.



SAFETY LABELS

1. Keep safety labels clean and legible at all times.
2. Replace safety labels that are missing or have become illegible.
3. Replaced parts that displayed a safety label should also display the current label.
4. Replacement safety labels are available. Contact USC at (785) 431-7900 .

How to Install Safety Labels:

- Be sure that the installation area is clean and dry.
- Be sure temperature is above 50°F (10°C).
- Decide on the exact position before you remove the backing paper.
- Remove the smallest portion of the split backing paper.
- Align the sign over the specified area and carefully press the small portion with the exposed sticky backing in place.
- Slowly peel back the remaining paper and carefully smooth the remaining portion of the sign in place.
- Small air pockets can be pierced with a pin and smoothed out using the piece of sign backing paper.



Located on the USC equipment you will find safety labels. Always be sure to read and follow all directions on the labels.



Guards provided with USC equipment are to remain in place during operation.

DRY ADDITIVE FEEDER



Part # 09-02-0001



Part # 09-02-0002



Part # 09-02-0012

DRY ADDITIVE FEEDER



Part # 09-02-0023



Part # 09-02-0010



Part # 09-02-0009

**SECTION
B**

INSTALLATION



HIGH VOLTAGE ~ Always disconnect the power source before working on or near the control panel or lead wires.



HIGH VOLTAGE ~ Use insulated tools when making adjustments while the controls are under power.



Permanent installation may require additional electrical cords, liquid hose, and air lines, since each installation is unique.



DO NOT modify any part of the Dry Additive Feeder, including the auger tube or add any mechanical device to attempt to change the way the product discharges from the end of the tube. This could pack the product tighter and change the flow rate of the product being added. It could also increase the pressure on the mechanical components of the drive assembly causing it to fail.

DO NOT leave product in the Dry Additive Feeder for extended periods of time as moisture could be absorbed causing the product to solidify. When the machine is started and the drive assembly is bound and unable to move, it will fail.

Failures caused by these actions will not be covered under the factory warranty (see page 59).

SET-UP

The following steps outline the initial set-up of the Dry Additive Feeder:

1. Clear the area of bystanders, especially small children, before moving.



USC highly recommends that the equipment be set up inside a building or any covered structure to protect the machine from weathering.

2. Remove the auger tube and the main assembly from the pallet.
3. Place the main assembly in the desired position on a level surface.
4. Remove the chain guard and set aside.

DRY ADDITIVE FEEDER

5. Remove the auger assembly from the feeder tube. Remove the nut and bolt from the reduced diameter end of the auger shaft. Insert the hex end into the feeder tube adjustment collar and into the shaft bearing adapter attached to the bearing on the other side of the assembly (bottom). The person inserting the auger can not see inside the machine. The process is much easier if a second person is looking down from the top of the hopper to help them guide the shaft into the adapter.

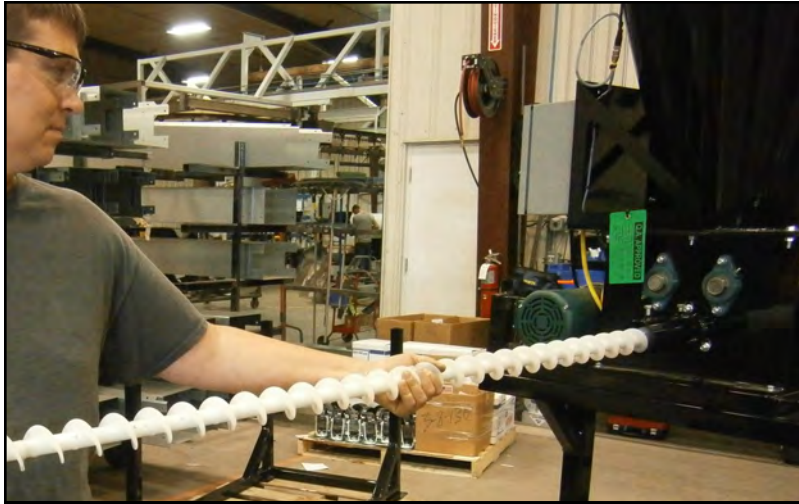

6. Once the shaft touches the end of the adapter, rotate the shaft slowly until the hex shaped end of the auger assembly engages the hex shaped opening of the bearing shaft adapter. Continue until the assembly is seated against the adapter.

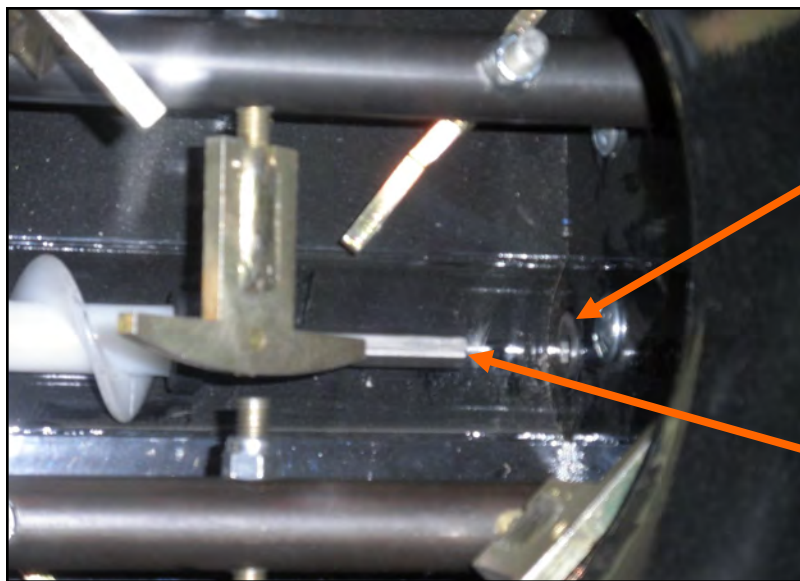

*Shaft Bearing
Adapter*

*Hex Shaft
End*

DRY ADDITIVE FEEDER

7. Use the washer and nut removed from the end of the hex shaft to fasten the end of the shaft assembly to the bearing shaft adapter on the opposite end of the machine. Then install the sprocket and drive chain.



8. Back off the auger tube mounting collar bolts far enough that they do not extend into the inside of the collar.

*Auger Tube
Mounting
Collar Bolts*

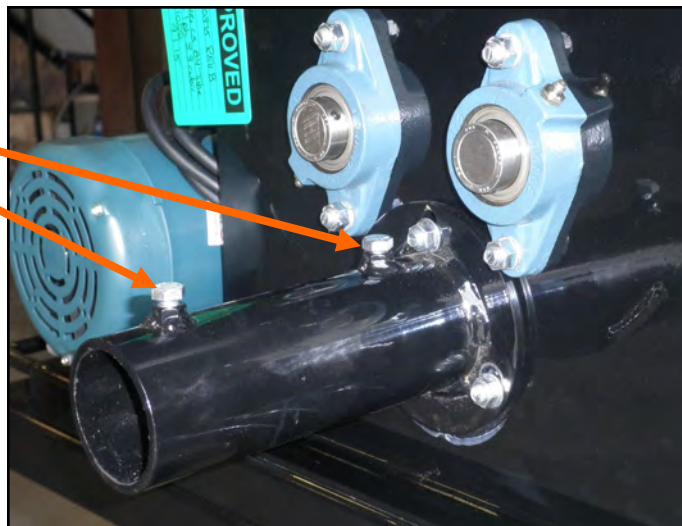

9. Slide the tube over the auger assembly and into the tube mounting collar until it is dead stop. Ensure that the slots in the tube are facing downward. Tighten both bolts to hold the tube in place.

10. Re-install the chain guard.

DRY ADDITIVE FEEDER

- 11. The Dry Additive Feeder may be installed in conjunction with a seed treater. This will allow the rotating drum to mix the dry product being applied with the seed.
- 12. The top portion of the feeder may be rotated and the height may be adjusted to accommodate most systems. The Dry Additive Feeder Assembly (13-05-0373) is bolted to the Adjustable Stand Assembly (13-05-0060). It may be rotated in 90 degree increments to allow for an easier working position in relation to other components such as the discharge conveyor.



Dry Additive Feeder in Conjunction with Seed Treater

- 13. Connect the 2-wire cable (PJ114) coming from the Dry Additive Feeder control panel to the auxiliary receptacle located on the bottom of the seed treater control panel. This will allow the operator to control the Dry Additive Feeder in the AUTO mode. For more information refer to the electrical operation section (see page 22).

Auxiliary Receptacle LPH800

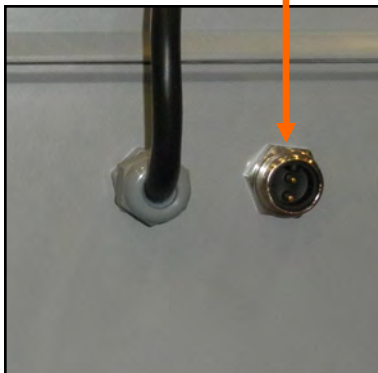

Auxiliary Receptacles Version 4 Treater

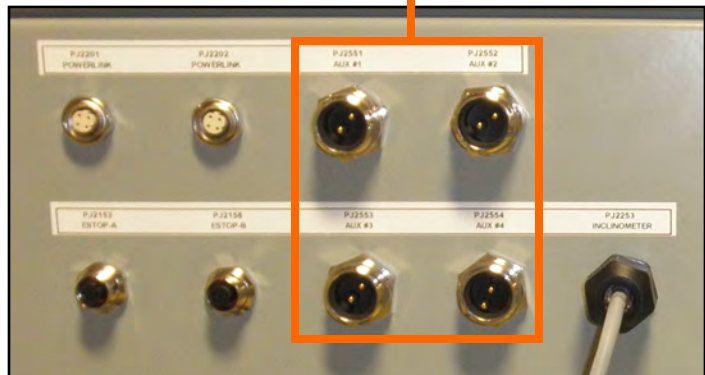

NOTICE

Some seed treaters may not be pre-wired with the auxiliary receptacle. Contact your local dealer for a kit to mount this receptacle in the seed treater control panel.

Part number: 03-12-0014.

SYSTEM OVERVIEW

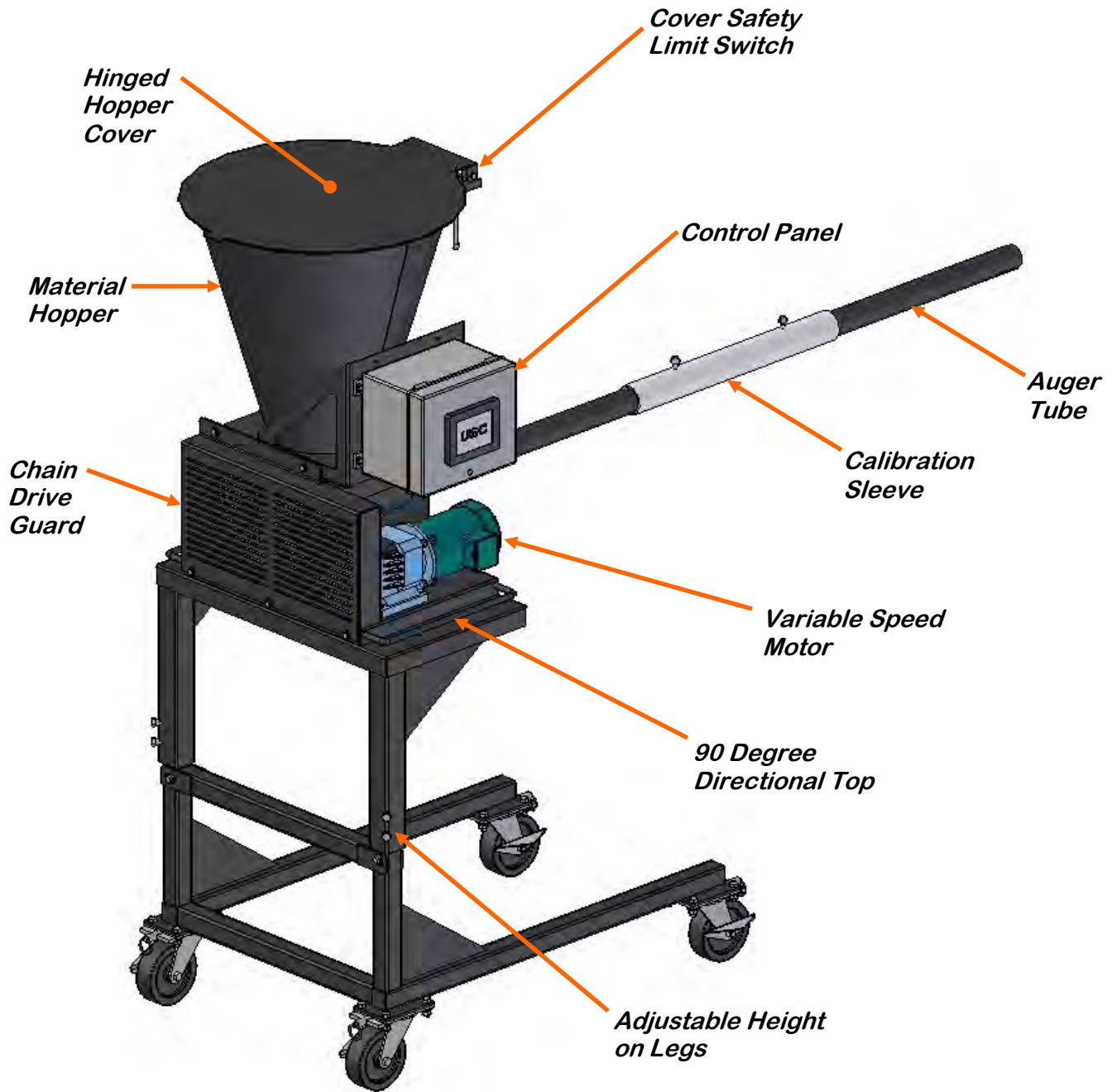

SYSTEM OVERVIEW

The USC Dry Additive Feeder is equipped with a holding bin, it has a capacity of 3.25 cubic feet. A 2 inch by 7 foot long auger is used to apply the dry products. Agitation paddles keep the product sifted so it feeds more efficiently into the auger. A variable speed motor drives the feeder auger and agitation paddles. The dry products are dispensed through openings in the last 22 inches of the auger tube.

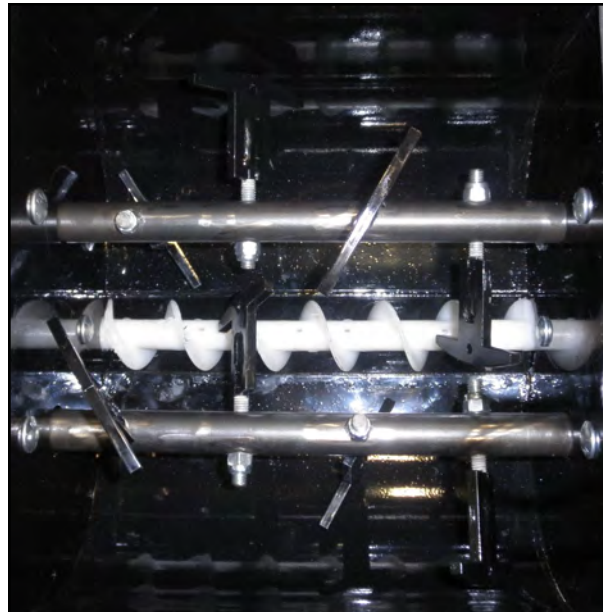

Agitation Paddles and Auger

The dry product is dispensed through small slots in the auger tube to create a curtain effect when the dry products are applied. The tube may be rotated to increase or decrease the coverage area.



SPROCKET CONFIGURATION

Proper calibration of the system is critical to achieve a proper application. The feeder auger is controlled by a variable speed motor. Use the calibration sleeve and measuring cup to determine the amount of dry product being dispensed. Rates should be determined in QTY / TIME. This will allow for proper mixtures.

The drive portion of the dry additive feeder may be re-configured to allow the motor to operate at a higher speed when the rate of product needed is low. For higher rates, the larger sprocket (30 tooth) should be mounted to the motor, and the smaller sprocket (21 tooth) should be mounted on the auger. Interchange the two sprockets if a very low rate is desired. For example, when using the dry additive feeder with a LPH800 treater, the smaller sprocket should be mounted to the motor. And when using the dry additive feeder with a LPX2000, the larger sprocket should be mounted to the motor (see below).

The gear mode in the HMI program needs to be set for the sprocket configuration. If the 30 tooth sprocket is on the motor shaft, it needs to be set to HIGH mode. If the 21 tooth sprocket is on the motor shaft, it needs to be set to LOW mode (see page 33).

***Auger Sprocket:
21 Tooth***

***Motor Sprocket:
30 Tooth***

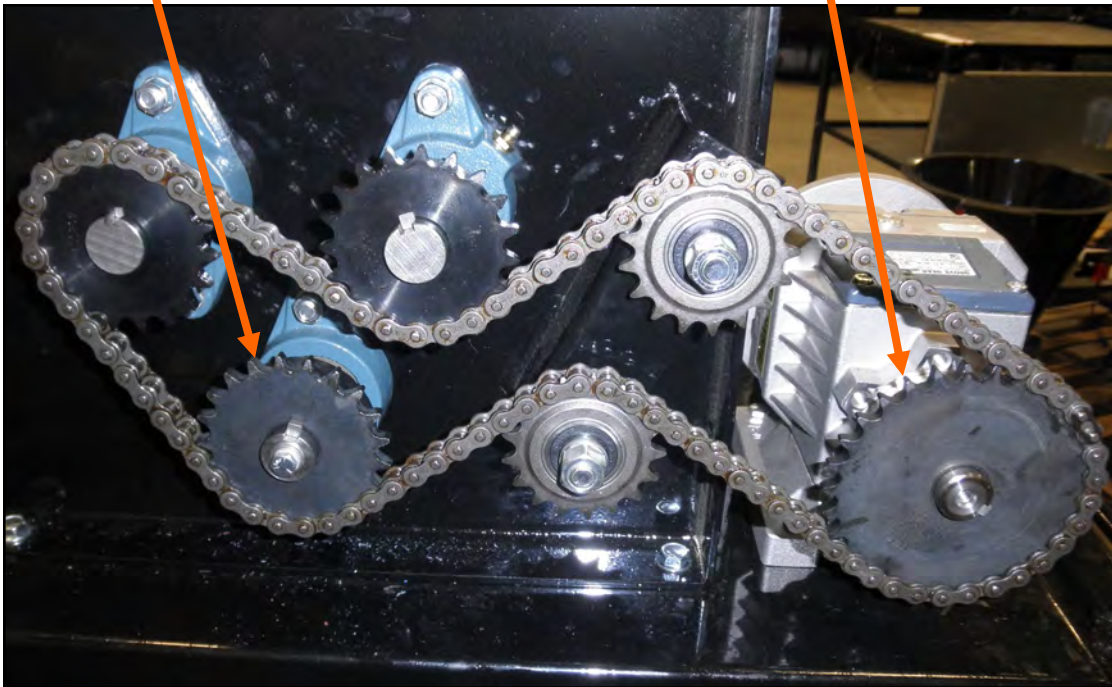

Sprocket configuration set up for use with LPX2000 Seed Treater

SPROCKET CONFIGURATION

⚠ WARNING

Before interchanging the motor and auger sprockets, be sure and mark the two agitation paddle shafts with arrows as illustrated below. Line the arrows back up when reinstalling the sprockets. Failure to line shafts back in original positions may cause the agitation paddles to collide and damage the machine.

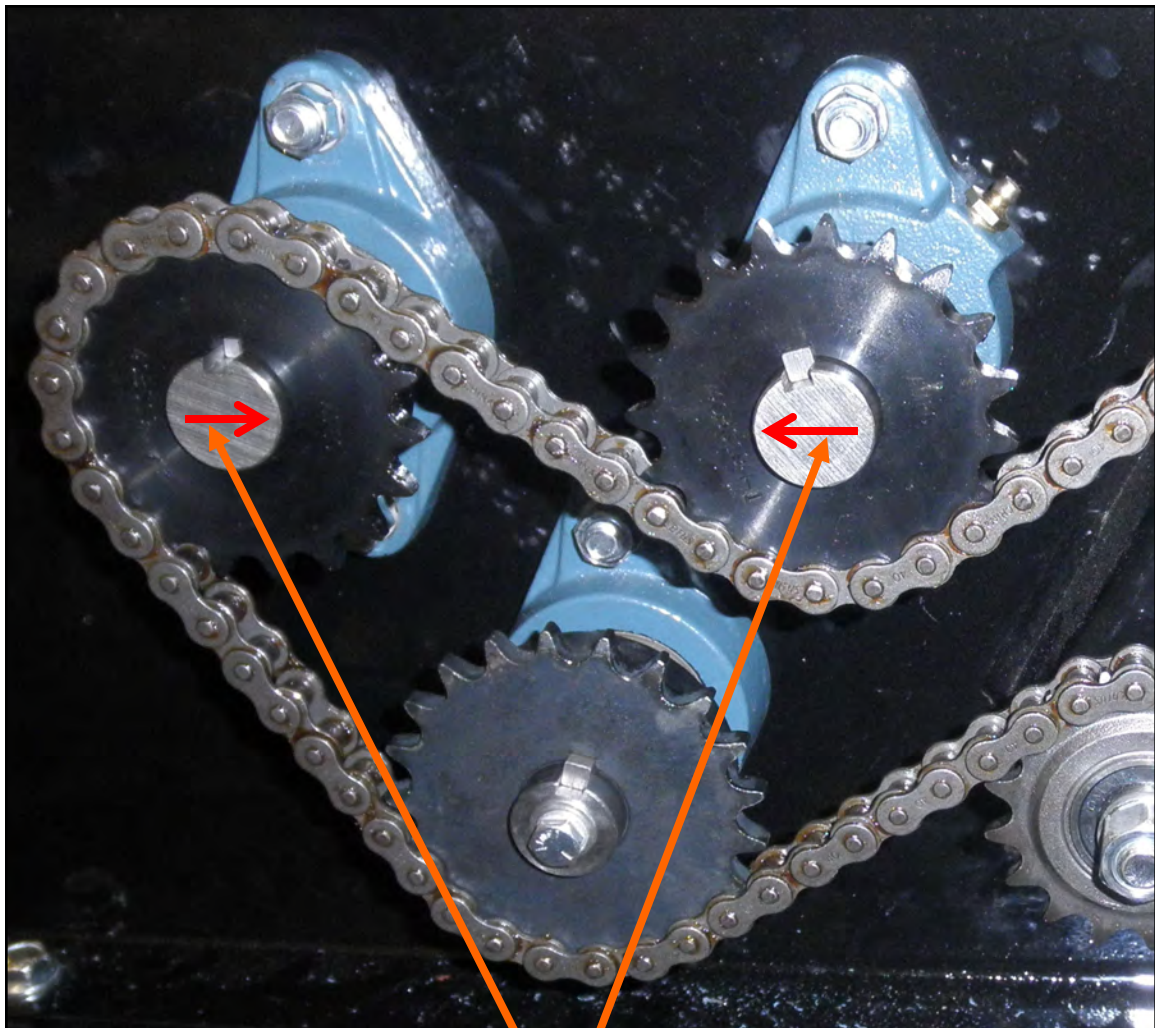

Agitation Paddle Shafts

SECTION
D

ELECTRICAL OPERATION



HIGH VOLTAGE ~ Always disconnect the power source before working on or near the control panel or lead wires.



HIGH VOLTAGE ~ Use insulated tools when making adjustments while the controls are under power.



AUTHORIZED PERSONNEL only shall work on the control panel. Never allow anyone who has not read and familiarized themselves with the owner's manual to open or work on the control panels.

DRY ADDITIVE FEEDER CONTROL PANEL

This section provides a general overview and description of the operator control panel for the Dry Additive Feeder. The Dry Additive Feeder panel is an enclosure that is attached to the side of the feeder and contains the electrical components required to actuate the feeder. This includes the VFD for the motor that runs the mixing paddles and auger. Power for the feeder is supplied here.



USC recommends the use of a surge protection device with a minimum rating of 400 Joules for all automated main control panels.



USC START UP SCREEN

The following pages explain the function of the touch screen controls for the Dry Additive Feeder v1.0.03 program.

While the system is booting up, the touch screen will display a timer bar at the bottom of the Start Up Screen. Once the timer bar reaches the end it will disappear and be replaced with flashing piece of text that reads **CLICK TO CONTINUE**. Select any where on the screen and it will advance to the Main screen.

This screen also displays the version of the software currently installed.



MAIN SCREEN

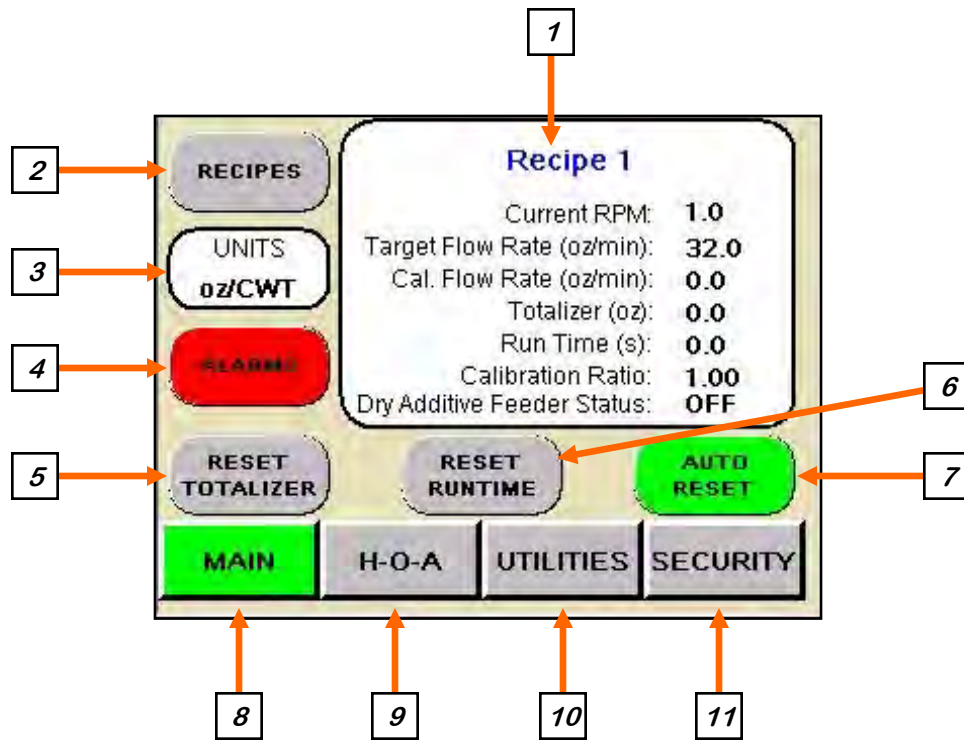

1. RECIPE STATUS BOX: Displays the name of the active recipe at the top, as well as the current RPM of the auger, target flow rate and the calculated flow rate. The totalizer displays the amount of material used. Run time displays the amount of elapsed time since the current run was started and the calibration ratio for the material being used.

2. RECIPES: Pressing this button advances the operator to the recipe screen (see page 26).

3. WEIGHT UNITS DISPLAY: This display indicates the unit of measurement being used for this recipe.

4. ALARMS: Pressing this button advances the operator to the alarms screen. When there is an active alarm it will turn red (see page 29).

5. RESET TOTALIZER: Pressing this button will reset the totalizer display after a run is complete.

6. RESET RUN TIME: Pressing this button will reset the run time display after a run is complete.

MAIN SCREEN

7. AUTO RESET: When this button is active it will automatically reset the totalizer and run time after each run is completed. If it is active it will be green.

8. MAIN: This button advances the operator to the main screen (see page 24).

9. H-O-A: This button advances the operator to the H-O-A screen (see page 30).

10. UTILITIES: This button advances the operator to the utilities screen (see page 31).

11. SECURITY: This button advances the operator to the security screen (see page 32).

NOTICE

Some of the screens have a round blue button with a question mark in the upper left corner of the screen. Selecting this button will bring up a help screen covering the functions of that screen.

RECIPES SCREEN

1. RECIPE SELECTION: Pressing this button advances the operator to the Select Recipe screen (bottom, left). Use the arrows to scroll through the list to find the recipe you wish to use. The system can store up to 20 recipes. Selecting an existing recipe will return you to the main screen. The recipe chosen is now displayed in the recipe status box.

2. RECIPE EDITING: Pressing this button advances the operator to the Editing Recipe screen (bottom, right). Select a recipe from the listing to modify or an unused

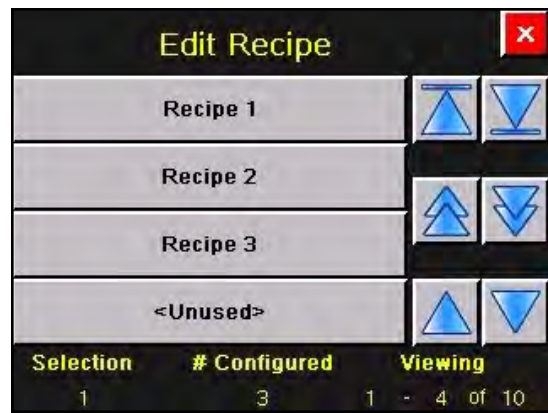
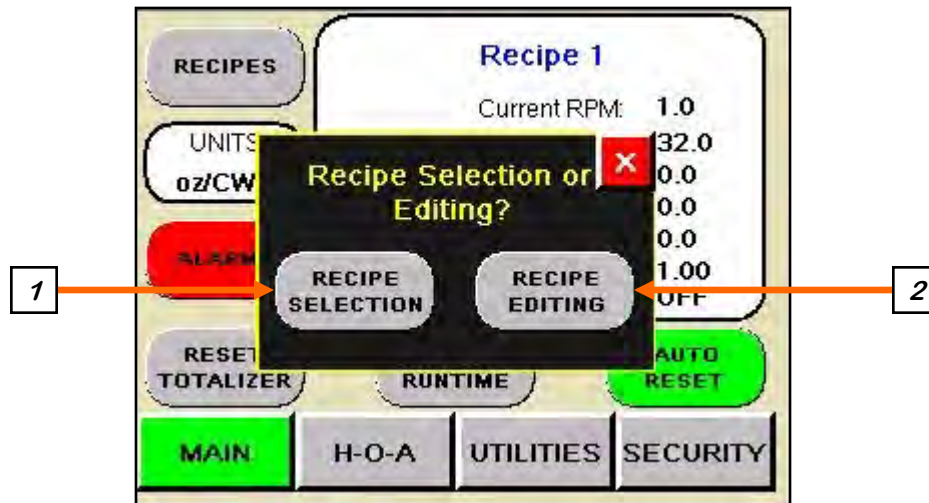

RECIPE EDITING SCREEN



1. NAME: Pressing this button brings up a keypad used to enter the name of the recipe.

2. UNIT OF MEASURE: Press this button and the Select Unit screen will appear (right). Use the arrows to scroll down through the options and select a measuring unit of product to apply to a measuring unit of seed.

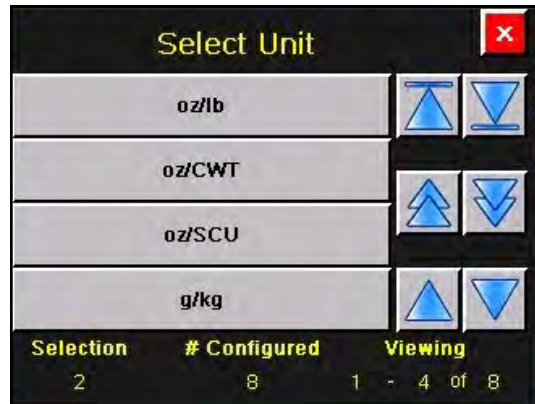

3. CALIBRATION RATIO: This button indicates the current calibration ratio defined on the calibration calculator screen (see page 28). Pressing this button brings up a keypad to allow the ratio to be changed directly from this screen.

4. PRODUCT APPLICATION: Pressing this button brings up a keypad to enter the volume of product to be applied per weight of seed.

5. PRODUCT FLOW RATE: Pressing this button brings up a keypad to enter the product flow rate for this recipe. This number must match the seed flow rate of the treater.

RECIPE EDITING SCREEN

6. PRODUCT DENSITY: Pressing this button brings up a keypad to enter the product density value. This option is only available when the density option setpoint is in the ON position (see page 33). It allows the operator to define a different density value for each recipe

7. SCREEN EXIT: Pressing this button returns the operator to the main screen.

8. CALIB.: Pressing this button advances the operator to the calibration calculator screen (below).

9. CLEAR: Pressing this button clears all of the parameters defined for this recipe

10. SAVE: When a parameter has been modified, the SAVE button will begin to flash green on and off as a reminder to press the button. If you leave the screen without pressing save, none of the information entered will be filed in the system.

CALIBRATION CALCULATOR SCREEN

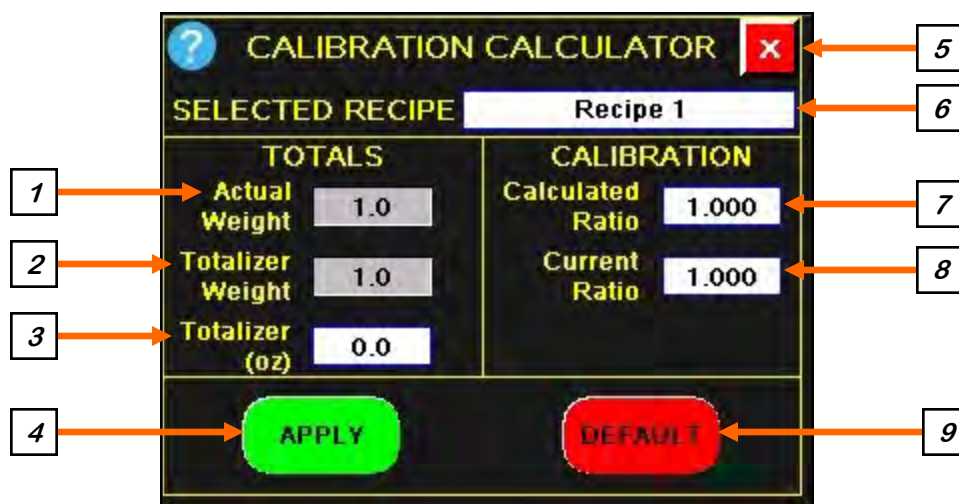

1. ACTUAL WEIGHT: Pressing this button brings up a keypad used to enter the actual weight applied during the calibration procedure (see page 34).

2. TOTALIZER WEIGHT: Pressing this button brings up a keypad to enter the number from the Totalizer (oz) display below it.

3. TOTALIZER (oz): This display indicates the amount of product the program estimates it received from the last run in ounces.

4. APPLY: After the actual weight and totalizer weight have been entered, the calculated ratio will be updated. Pressing this button returns the operator to the recipe editing screen and updates the calibration ratio.

CALIBRATION CALCULATOR SCREEN

5. SCREEN EXIT: Pressing this button returns the operator to the recipe editing screen.

6. SELECTED RECIPE: This display indicates the name of the recipe for this calibration.

7. CALCULATED RATIO: This display indicates the amount the current calibration will be adjusted when the apply button is pressed

8. CURRENT RATIO: This display indicates the current calibration.

9. DEFAULT: Pressing this button returns all values to the default setting of one.

ALARMS SCREEN

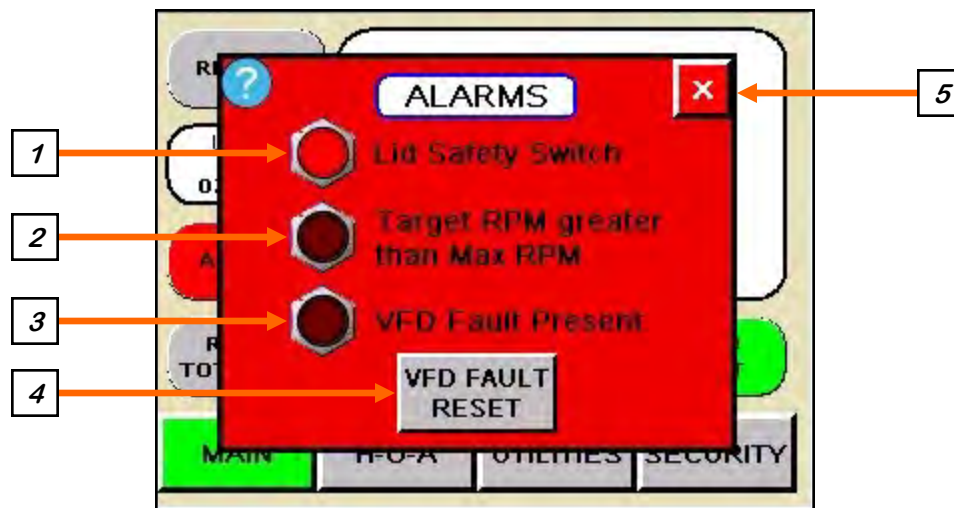

1. LID SAFETY SWITCH: This alarm occurs when the hopper lid is open. There is a limit switch that detects if the lid is open. Close the lid and the alarm will reset.

2. TARGET RPM GREATER THAN MAX RPM: There is a setpoint defining a maximum RPM for the auger. If the system settings are configured so the RPM exceeds the setpoint value, the system will shutdown.

3. VFD FAULT PRESENT: This alarm occurs when the drive motor VFD fault is detected.

4. VFD FAULT RESET: Pressing this button sends a reset VFD fault command to the VFD. If this does not clear the fault, the operator may need to re-start the system.

5. SCREEN EXIT: Pressing this button closes the alarm screen.

H-O-A SCREEN

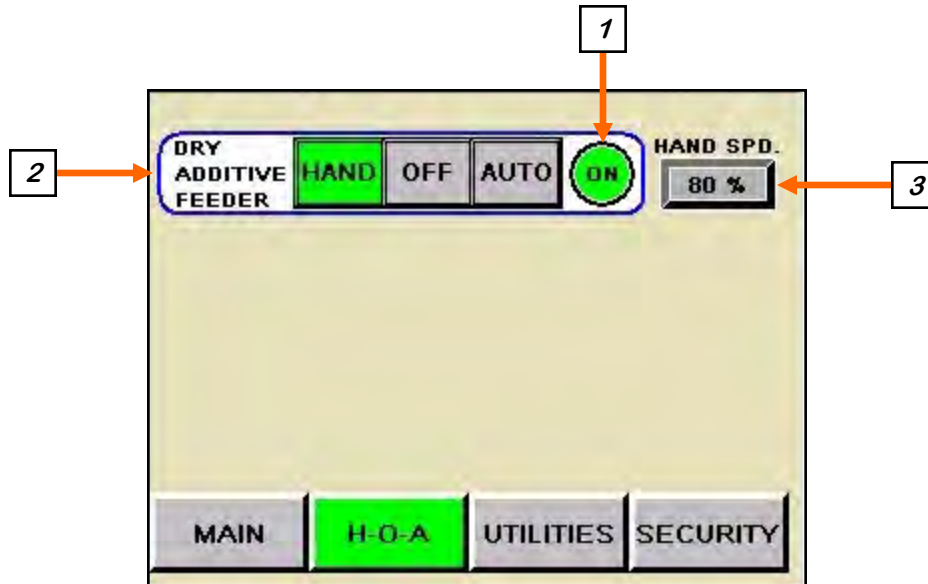

1. MOTOR STATUS INDICATOR: This displays the motor status. When the motor is on it will be green. When it is off it will be red.

2. DRY ADDITIVE FEEDER H-O-A MODULE: This module controls the function of the feeder motor. The HAND button will place the feeder motor on in the manual mode of operation. When it is active it will turn green. The OFF button will turn the motor OFF in the manual mode of operation. When it is active it will turn red. The AUTO button will place the device in the automatic mode of operation. When it is active it will turn yellow. This button is used when the feeder is attached to a seed treater. This allows the treater to turn the feeder on and off at the appropriate time.

5. HAND SPD.: This button brings up a keypad that allows the operator to enter a percentage of maximum speed to control the motor when operating in HAND mode.

UTILITIES SCREEN

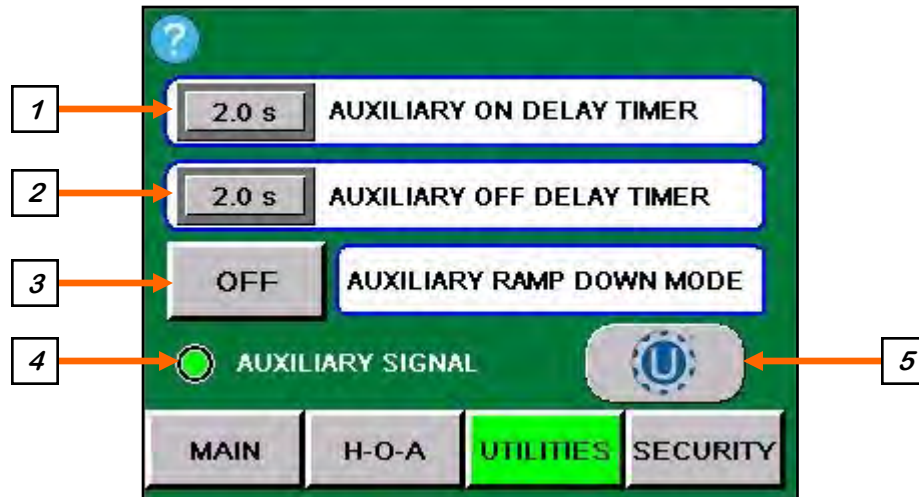

1. AUXILIARY ON DELAY TIMER: Pressing this button allows the operator to adjust the delay time in one tenth of a second increments to determine how long after the treater has sent the start signal to the feeder before the motor starts. This is active when the feeder is operating in AUTO mode.

2. AUXILIARY OFF DELAY TIMER: Pressing this button allows the operator to adjust the delay time in one tenth of a second increments to determine how long after the treater has sent the stop signal to the feeder before the motor stops. This is active when the feeder is operating in AUTO mode.

3. AUXILIARY RAMP DOWN MODE: If this button is OFF, the machine will run at the designated speed from the time the treater sends the stop signal until the specified delay time has elapsed. If it is ON, it will gradually reduce speed from the time the stop signal is received until the specified delay time has elapsed. The longer the delay time that is entered, the more gradual the speed reduction will be.

4. AUXILIARY SIGNAL: This indicator will be green when the feeder is receiving an auxiliary signal from the treater. It will be black when it is not.

5. START-UP SCREEN: This button returns the operator to the starter screen (see page 23).

SECURITY SCREEN

1. PASSWORD ENTRY: The operator uses this input to obtain access to the setpoints screen. When this button is pressed an alpha numeric keypad will appear. The password is **USC** and should only be made accessible to personnel qualified to operate the system.

2. LOGIN: Pressing this button **after** the password has been entered will activate the SETPOINT button.

3. LOGOUT: Pressing this button will de-activate the SETPOINT button.

4. SETPOINTS: Pressing this button advances the operator to the SETPOINTS screen (see page 33).

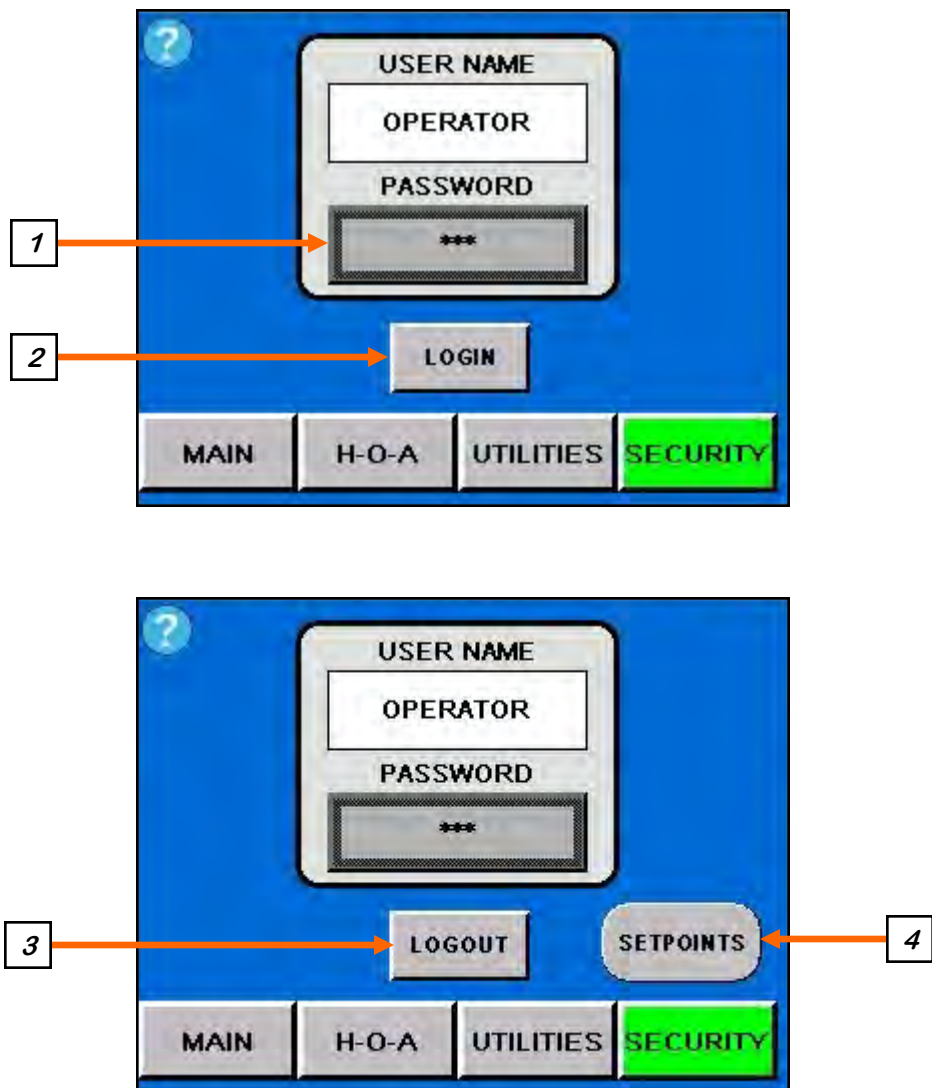

SETPOINTS SCREEN

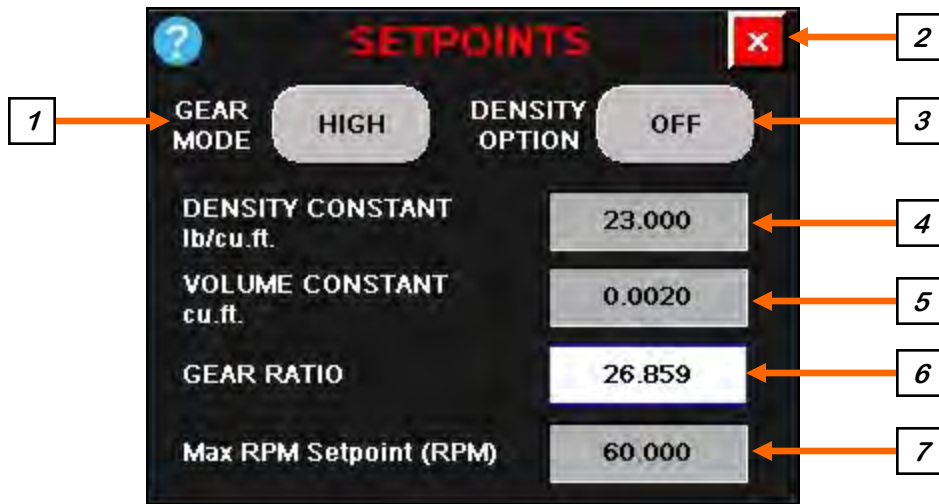

1. GEAR MODE: This button toggles between the HIGH and LOW gear mode. The feeder is shipped with the gears set in the high speed configuration and with this set to high. The low setting is for use with a low flow rate treater (see page 20).

2. SCREEN EXIT: Pressing this button returns the operator to the security screen.

3. DENSITY OPTION: This button toggles between the ON and OFF mode. If off, it allows the operator to set a density that will be used for all recipes. When on, the density may be set for each individual recipe.

4. DENSITY CONSTANT: This value becomes the system default when the density option is in the off mode. It would then be used for all recipes.

5. VOLUME CONSTANT: This value represents the volume of material dispensed by the system from one revolution of the auger .

6. GEAR RATIO: This indicator displays the motor to auger gear ration. It only changes when the gear mode is toggled from one setting to the other.

7. MAX RPM: This value sets the maximum RPM for the auger. If the target RPM exceeds this number the system will go to an alarm state and stop the run. The speed entered must not be higher than the auger can physically achieve. The maximum RPM in high speed mode is 64, for low speed mode it is 30 (see page 29).

SECTION
E

CALIBRATION

DRY PRODUCT CALIBRATION

When calibrating the dry product, a small scale and a measuring cup or bucket will be needed. Additional information such as treater seed flow rate and dry product application rate will also be needed for calibration.

1. Calibrate the seed flow of the seed treater before calibrating the Dry Additive Feeder. Refer to the operators manual for seed treater calibration instructions.
2. Fill the supply hopper with the dry product being applied.
3. Slide the calibration sleeve toward the end of the auger tube to cover the distribution slots (top picture).
4. From the H-O-A screen, set the hand speed to 75%, then press the HAND button.
5. Allow product to fill the auger all the way to the end of the tube. Use the measuring cup or bucket to catch the product as it empties out the end of the tube. Continue running the auger until there is a consistent stream of product coming out the end. Then turn the H-O-A to OFF. Empty the receptacle.
6. From the Security screen, select the Password button and key in **USC**, then press the Login button. It will toggle to Logout and the Setpoints button will appear
7. The next step is to define the product density. Press the setpoints button and choose one of two density options. If the operator is using similar products for all recipes, set the Density Option button to OFF and enter the density value for that product using the Density Constant button. If they want the flexibility to define a unique density for each individual recipe, set the button to ON. When set to ON, a Product Density button will appear at the bottom of the Recipe Editing screen.



Calibration Sleeve at end of Auger Tube

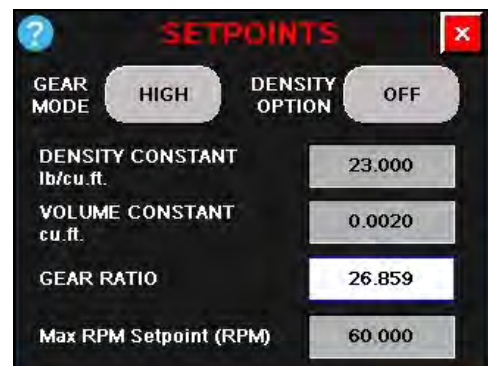
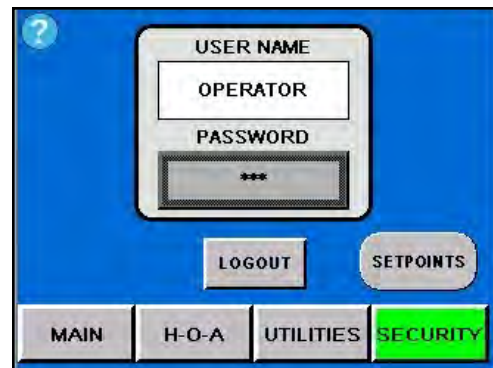

8. From the recipe editing screen, select the unit of measure, enter a value for product to seed application rate, treater seed flow rate and if the button is present, product density. Press the save button. The information for these variables will need to be obtained by the operator from the treater settings and product labels or vendors.
9. Place the measuring cup on the scale and zero the weight of the cup. Then place the measuring cup under the end of the feeder tube.
10. The calibration should run at a rate similar to the rate the product will be applied, which is the calculated rate based on the settings. From the H-O-A screen, press the HAND button. Return to the main screen and monitor the run time display at the bottom of the recipe status box. The run time needs to be a minimum of one minute before returning to the H-O-A screen and pressing the OFF button. The longer the system is run during calibration the more accurate it will be. Be careful not to let any of the product overflow the catch receptacle as this will give an incorrect scale reading when it is weighed.
11. Place the cup of product on the scale to weigh the amount of product that was dispensed.
12. From the calibration calculation screen, press the Totalizer Weight button and enter the number from the Totalizer (oz) display. Press the Actual Weight button and enter the weight of the product in the cup. Press the apply button to be returned to the recipe editing screen. Notice the calibration ratio has been updated. Press the save button to file the calibration and to be returned to the main screen.

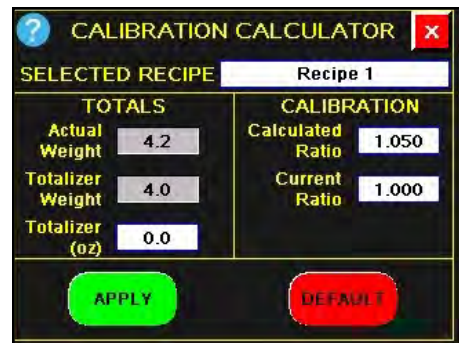
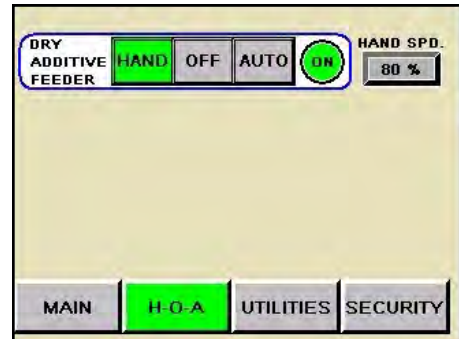
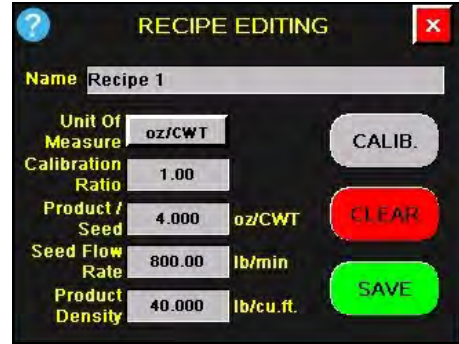

NOTICE The unit of measurement of the scale used must be the same as the unit of measurement defined in the recipe. Both in ounces or both in grams.

NOTICE A higher calibration ratio will result in a lower auger RPM and a Lower calibration ratio in a higher auger RPM.

SECTION F TROUBLESHOOTING

Below is a table describing the most frequent mechanical problems and solutions with the USC Dry Additive Feeder. For further assistance, contact USC at (785) 431-7900.

Problem	Possible Cause	Solution
Dry Additive Feeder will not turn on in AUTO	<ol style="list-style-type: none"> 1. Proximity Switch in treater is not detecting seed. 2. Proximity switch in treater is not sensitive enough. 3. Atomizer is not running. 	<ol style="list-style-type: none"> 1. Clean proximity switch. 2. Adjust proximity switch clockwise to make more Sensitive (see page 37). 3. Turn on atomizer.
Dry Additive Feeder will not turn off in AUTO when seed runs out.	<ol style="list-style-type: none"> 1. Proximity Switch in treater is still detecting seed after run. Switch is dirty. 2. Proximity Switch is too sensitive. 	<ol style="list-style-type: none"> 1. Clean proximity Switch 2. Adjust proximity switch counter-clockwise to make less Sensitive (see page 37).
Feeder Rate is Fluctuating.	<ol style="list-style-type: none"> 1. Product is not feeding into auger. 2. Agitators are not working properly. 3. Running auger too slow. 	<ol style="list-style-type: none"> 1. Check to see if product is feeding into the auger. 2. Check tightness on chain 3. Interchange sprockets to make auger shaft to run faster (see pages 20-21).
Auger will not turn.	<ol style="list-style-type: none"> 1. Agitation paddles are hitting each other. 2. Chain is loose. 	<ol style="list-style-type: none"> 1. Readjust agitation paddles so they do not collide when running. 2. Check tightness on chain.

PROXIMITY SWITCH ADJUSTMENT GUIDE

If the proximity switch is not working properly, this can be caused by wear, dust, or even moisture. The first step is to clean the lens of the proximity switch. If this does not solve the problem, the next step would be to adjust the sensitivity of the proximity switch.

The green light indicates the power status. If it is active the device is powered.

The amber light indicates when seed is being detected. If it is active it detects seed, if inactive it does not detect seed.

Using the small screwdriver provided inside the control panel, you can adjust the proximity switch by turning the adjusting screw on the back of the proximity switch.

- Turn Clockwise to make the proximity switch more sensitive.
- Turn Counterclockwise to make the proximity switch less sensitive.

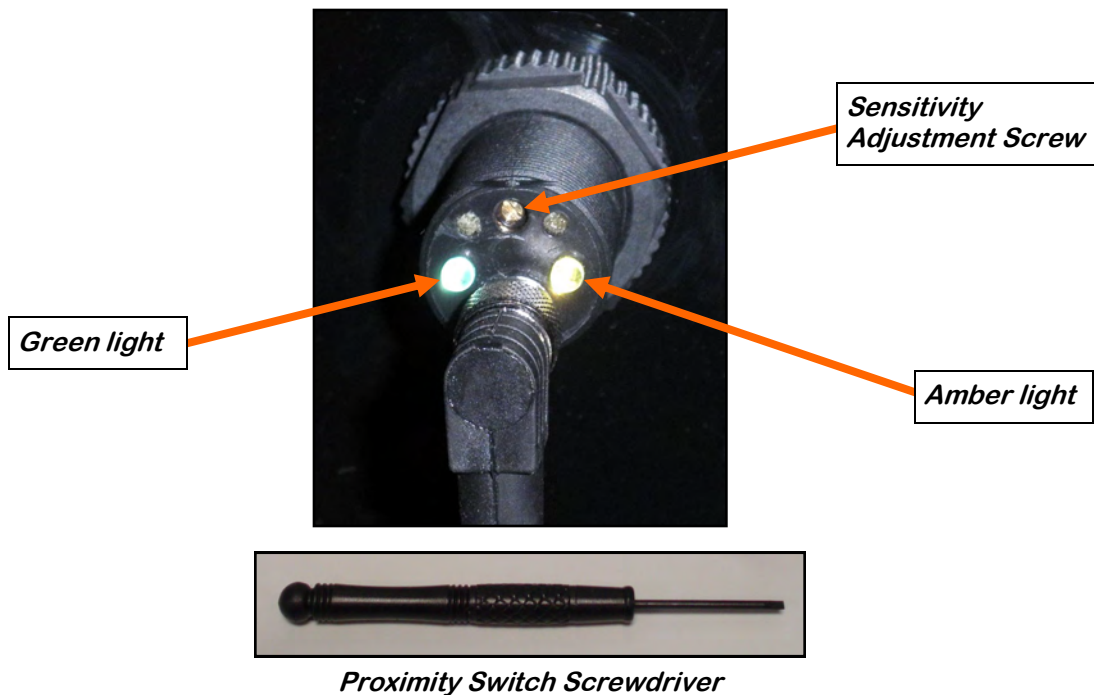

**SECTION
G****MAINTENANCE**

Proper maintenance of the USC Dry Additive Feeder is critical for peak performance, reliability and accuracy of this system. The following is a guideline for the type of maintenance and servicing that should be performed on this unit. Your environment and uses may require additional maintenance and service beyond this list to assure a reliable and safe unit. The operator of this unit has ultimate responsibility to identify areas of concern and rectify them before they become a hazard or safety issue. There is no substitute for a trained, alert operator.



Do not put this unit into operation with any questionably maintained parts. Poor performance or a hazard may occur.

GREASING

Use an SAE multipurpose high temperature grease with extreme pressure (EP) performance. Also acceptable is an SAE multipurpose lithium-based grease.

1. Use a Maintenance Checklist to keep record of all scheduled maintenance.
2. Use a hand-held grease gun for all greasing.
3. Wipe grease fitting with a clean cloth before greasing to avoid injecting dirt and grit.
4. Replace and repair broken fittings immediately.

NOTICE

If fittings will not take grease, remove and clean thoroughly. Also clean lubricant passageway. Replace fitting if necessary.

SUPPLY HOPPER

1. Periodically clean out any build up of dry material in the hopper.
2. Check agitation paddles for wear, breaks or an loose fasteners.
3. Check auger for wear or breaks.

CHAIN DRIVE AND BEARINGS

1. Remove chain drive guard and inspect all welds and structural components on the frame bends, cracks and damage.
 2. Tighten and lubricate chain every 40 hours of operation.
 3. Inspect pillow block bearings and grease every 40 hours of operation.
-

ELECTRICAL PANEL

1. Check and tighten wire connections.
2. Check quick connects on bottom of control panel.
3. Check to see if starters and/or overloads are tripped.
4. Check to see if relays, timers and/or breakers are tripped.
5. Check quick connects on end of Auxiliary cord.
6. Check relay and fuse holder.
7. Check power cords for cuts or frays and ensure ground is present.

**SECTION
H**

STORAGE

When storing the USC Dry Additive Feeder for long periods of time, the following procedure must be followed to reduce the chance of rust, corrosion and fatigue of the equipment. You can also use these steps when storing the machine for the winter.



A dust mask and protective rubber gloves shall be used when cleaning the machine.

1. Disconnect power to the machine.
2. Clean out the supply hopper of any debris (compressed air may be used).
3. Remove auger tube and clean the auger (compressed air may be used). Then reinstall the auger tube.
4. Remove the drive chain guard and clean out any material that may have fallen behind the guard.
5. Follow the maintenance procedures specified for the chain drive and bearings on page 39.
6. Disconnect power to the machine.
7. Store the machine inside a protective building to keep it from being exposed to the weather.
8. Cover the Dry Additive Feeder with a tarpaulin to keep dust and dirt out of the machine.

DRY ADDITIVE FEEDER

NOTES:

SECTION
I

MECHANICAL DRAWINGS

HOPPER AND LID ASSEMBLY (05-07-0836)

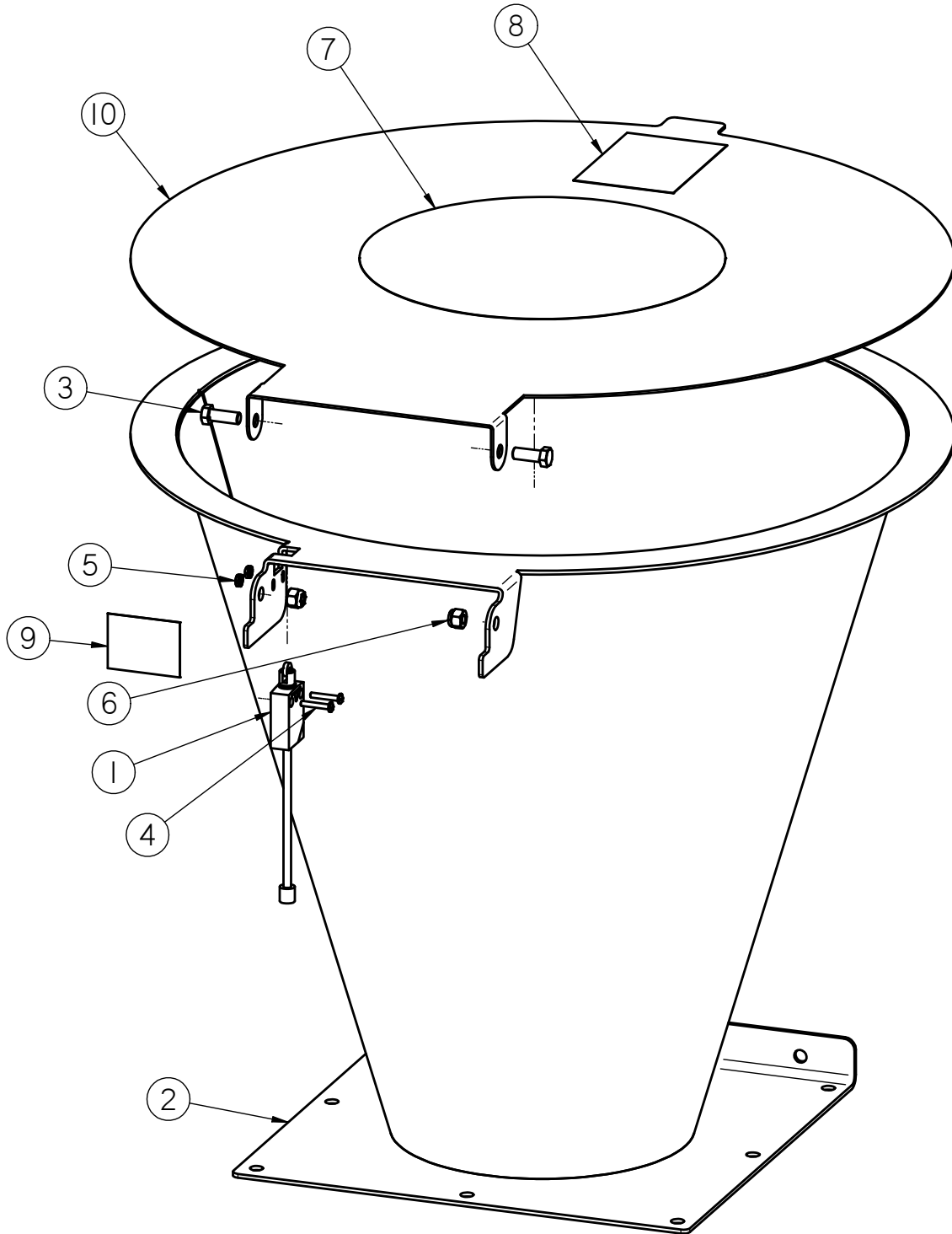

DRY ADDITIVE FEEDER

HOPPER AND LID ASSEMBLY (05-07-0836)

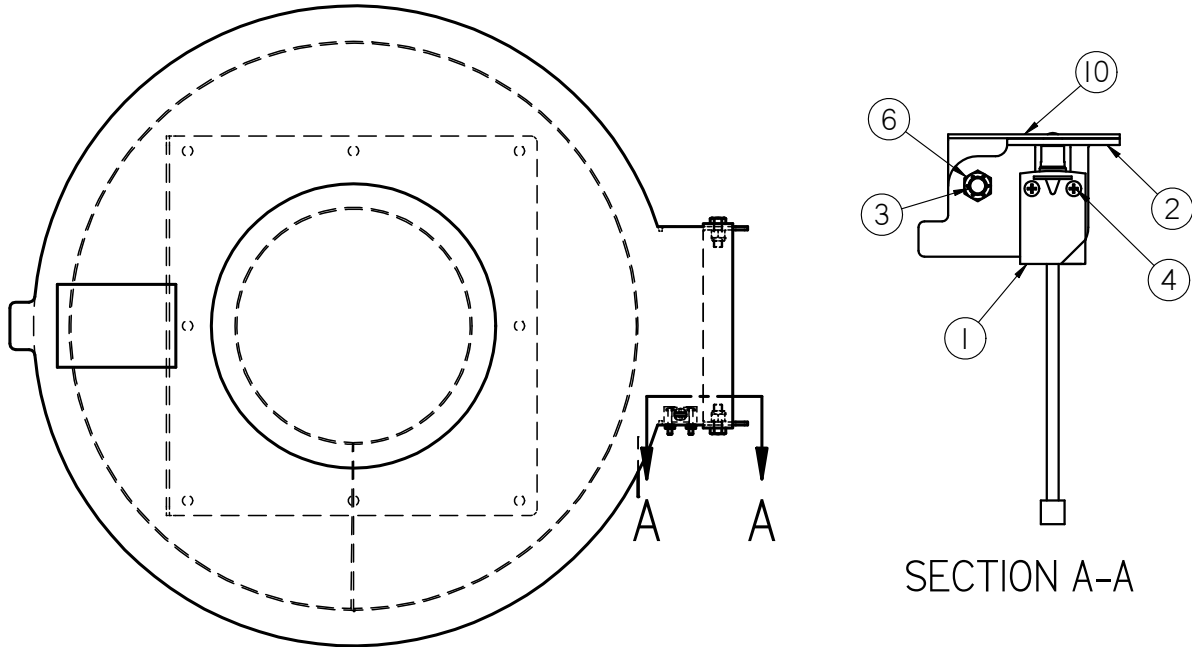

Item #	Part #	Description	Qty
1	03-10-0156	SW LMT AB RLR PLNGR 440P-ARPS11D5	1
2	05-07-0833	WDMT DAF TOP HPPR CONE CS	1
3	06-01-0016	BOLT .375-16 X 1.00 ZP GR5	2
4	06-01-0094	SCRW PAN HD 8-32 X 1.00 ZP	2
5	06-02-0034	NUT 8-32 K-LOCK ZP	2
6	06-03-0003	NUT NYL LOCK .375-16 ZP GR5	2
7	09-01-0044	LABEL USC LOGO	1
8	09-02-0002	ATWK LBL DANGER GUARDS	1
9	09-02-0023	ATWK LBL DO NOT BYPASS INTERLOCK	1
10	104521	DAF LID	1

ADJUSTABLE SUPPORT FRAME ASSEMBLY (13-05-0060)

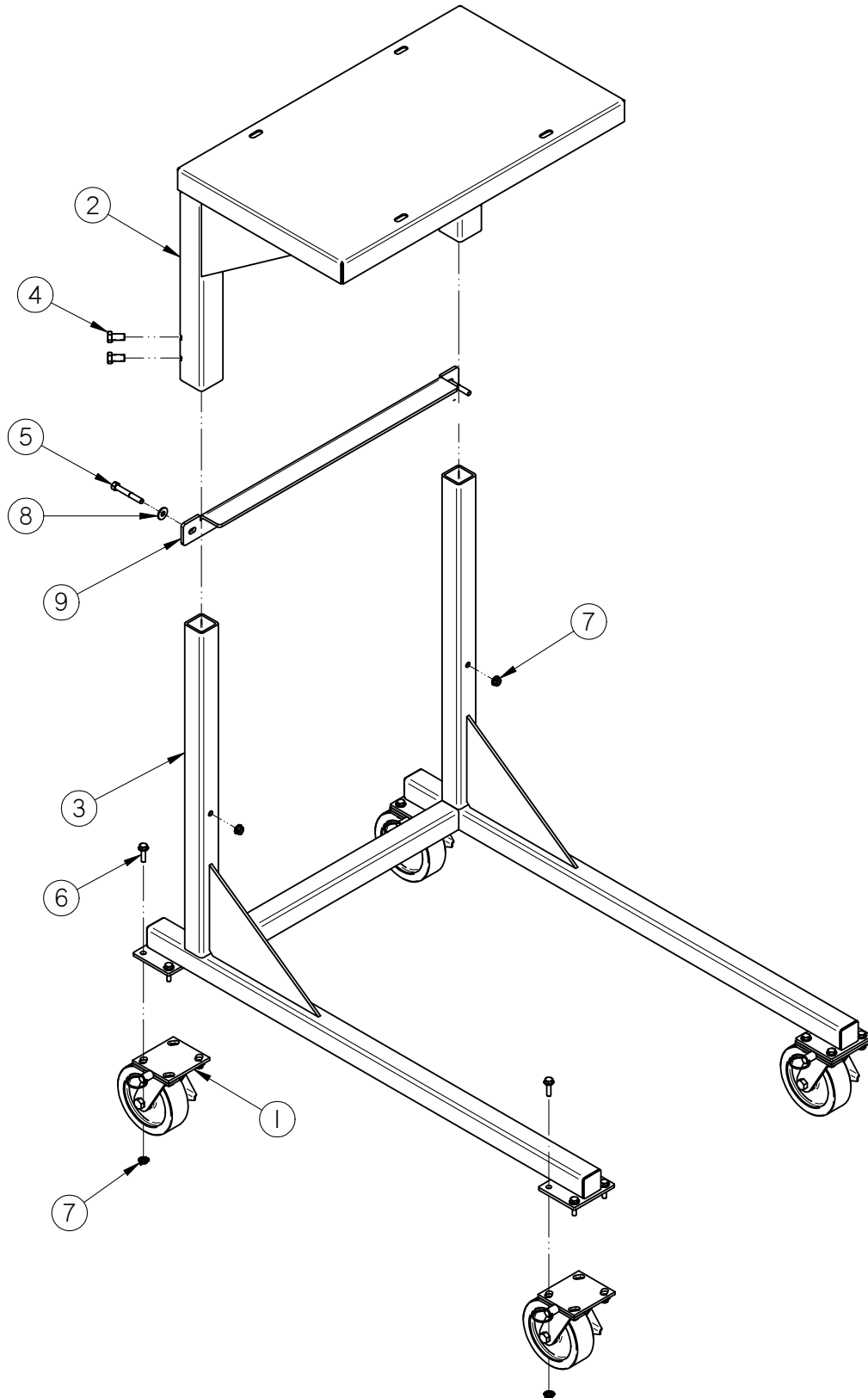

DRY ADDITIVE FEEDER

ADJUSTABLE SUPPORT FRAME ASSEMBLY (13-05-0060)

Item #	Part #	Description	Qty
1	01-06-0172	WHL CSTR 6.0 X 2.0 SWVL CI 1100#	4
2	05-03-0294	WDMT DAF FRM UPPER CS	1
3	05-03-0295	WDMT DAF FRM LOWER CS	1
4	06-01-0069	BOLT .500-13 X 1.00 ZP GR5	4
5	06-01-0116	BOLT .375-16 X 2.75 ZP GR5	2
6	06-01-0189	BOLT FLG .375-16 X 1.250 ZP GR5	16
7	06-03-0014	NUT LOCK FLG .375-16 ZP GR5	18
8	06-05-0004	WSHR FLAT .375 ZP	2
9	1056F0	ANGLE BRACE DAF	1

DRY ADDITIVE FEEDER
BASE ASSEMBLY (13-05-0535)

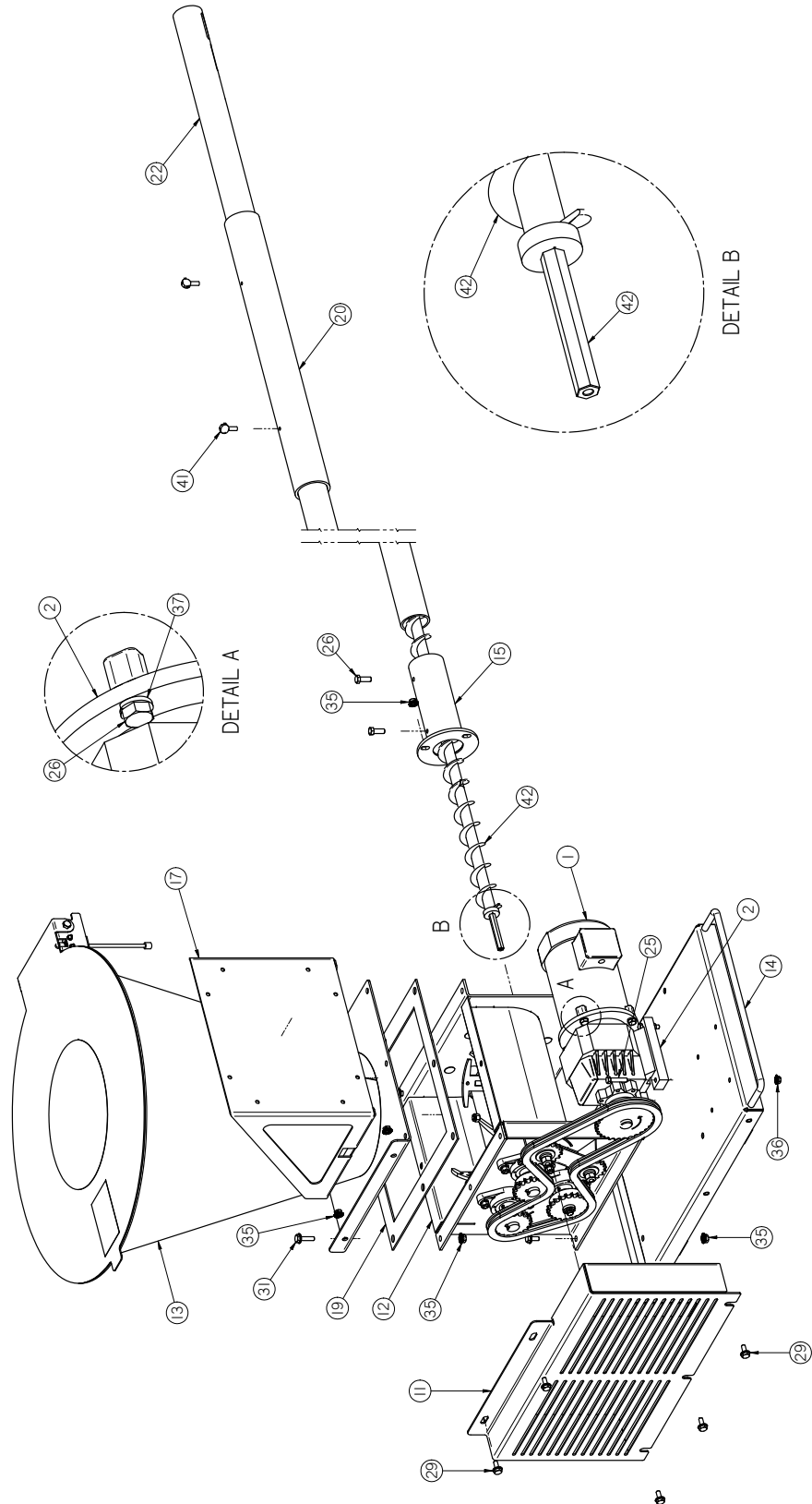

DRY ADDITIVE FEEDER
BASE ASSEMBLY (13-05-0535)

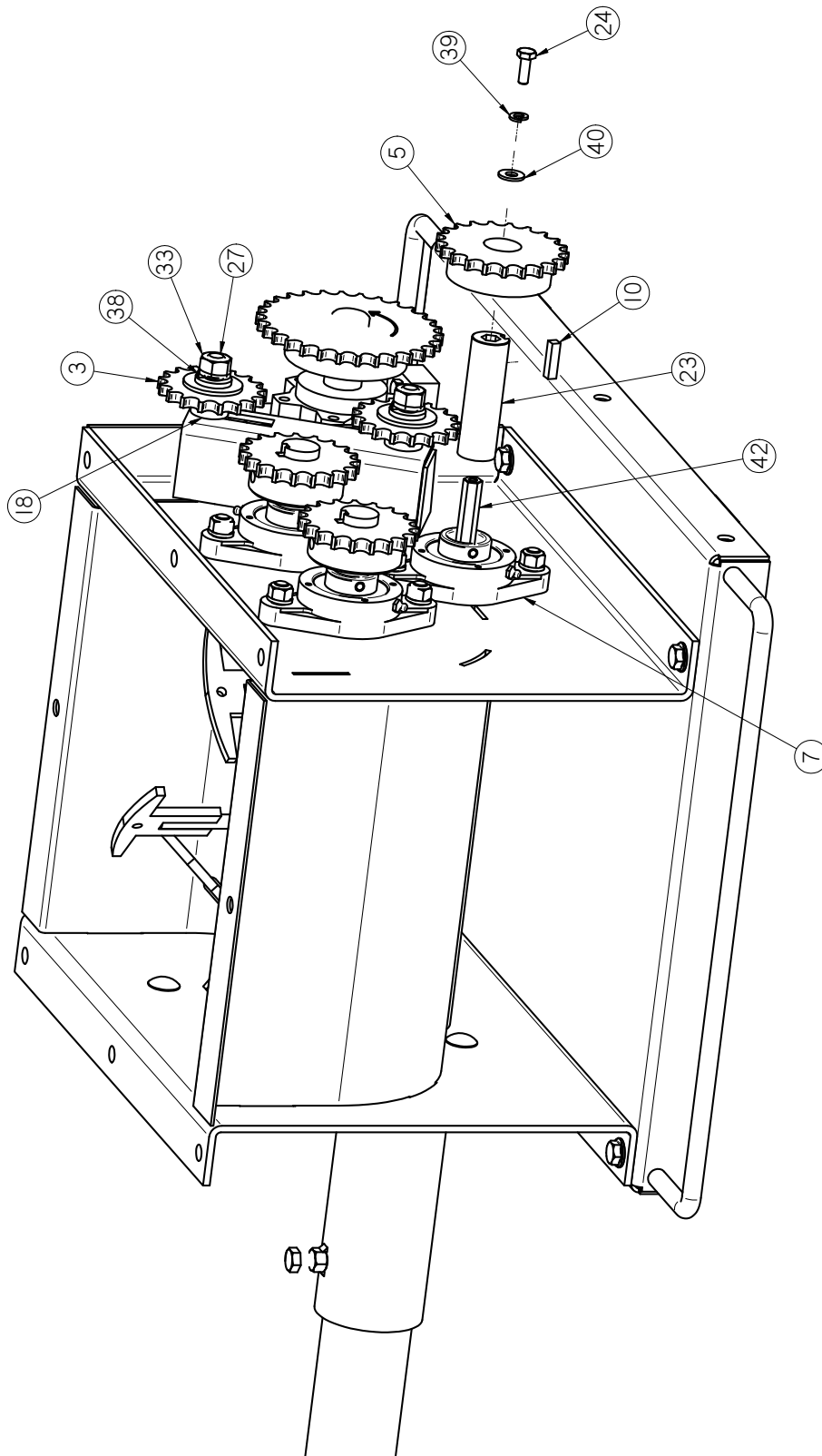

DRY ADDITIVE FEEDER
BASE ASSEMBLY (13-05-0535)

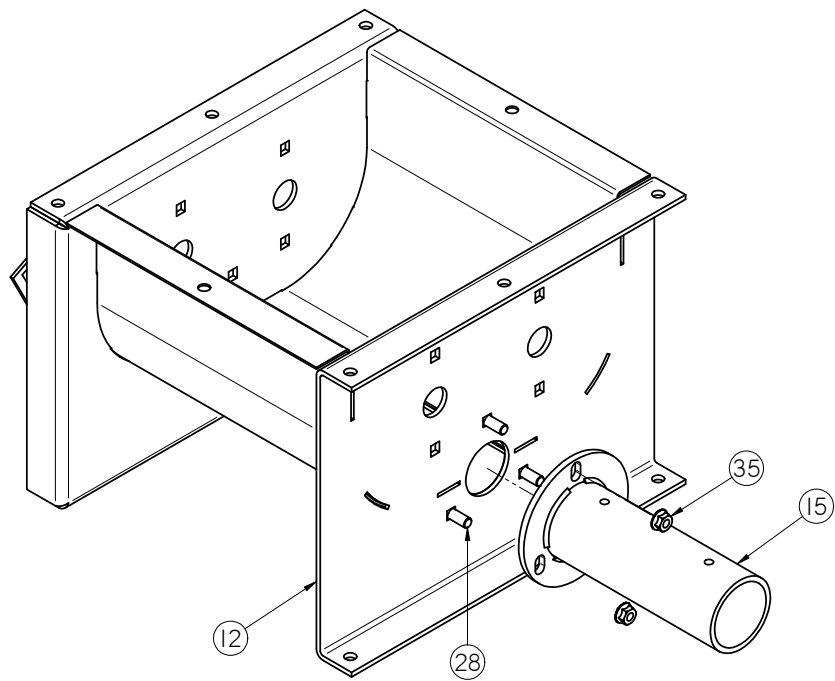
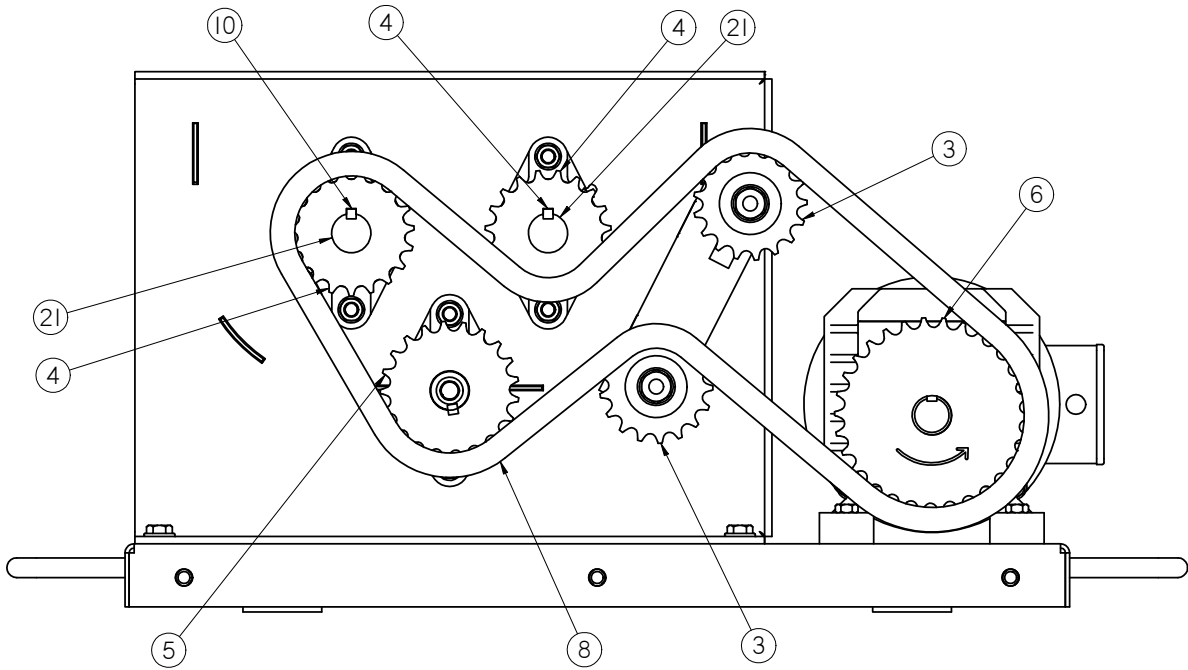

DRY ADDITIVE FEEDER

BASE ASSEMBLY (13-05-0535)

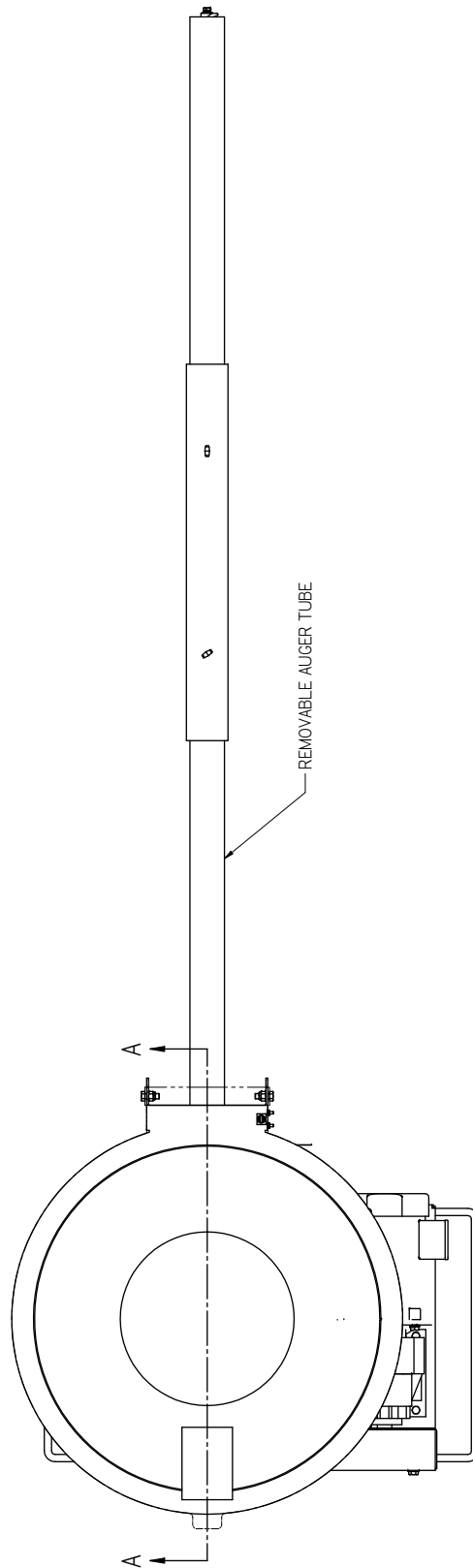

DRY ADDITIVE FEEDER
BASE ASSEMBLY (13-05-0535)

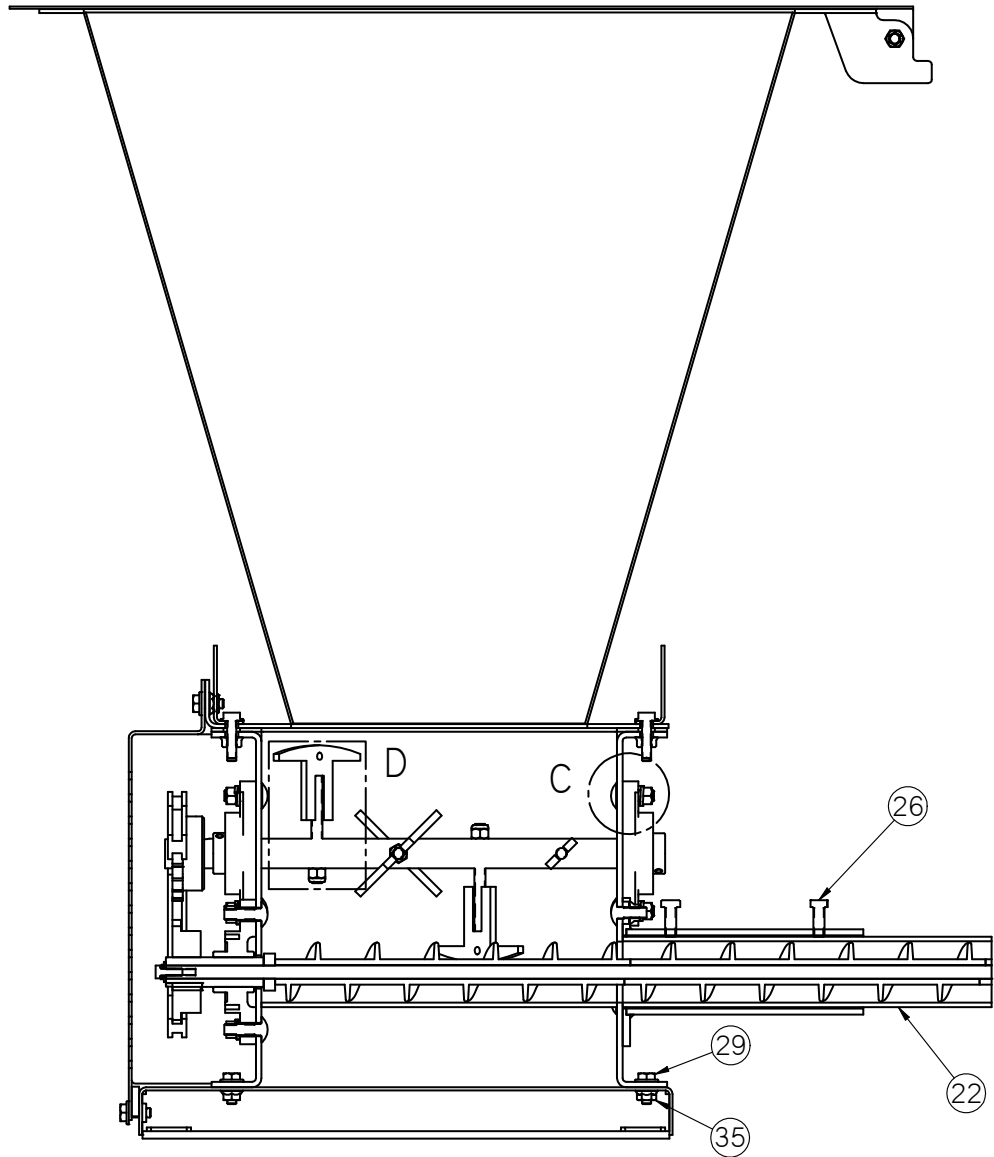

SECTION A-A

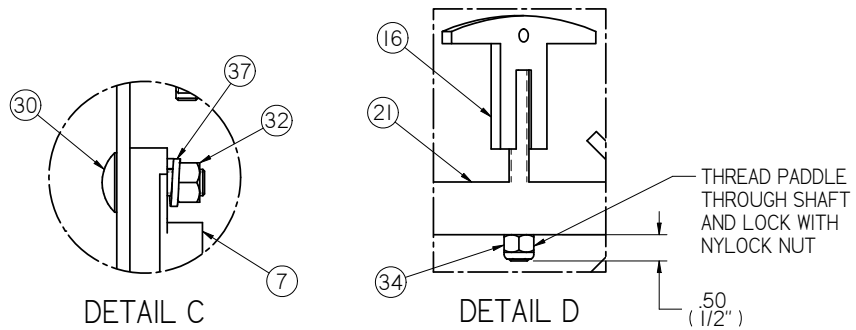

DRY ADDITIVE FEEDER

BASE ASSEMBLY (13-05-0535)

Item #	Part #	Description	Qty
1	01-01-0087	MTR .5HP 1725RPM S56C 3PH INDY	1
2	01-01-0109	GBOX 56C FR 38.37:1 GR 46 RPM OUT	1
3	01-02-0001	SPKT 17T 40P .500ID IDLER	2
4	01-02-0003	SPKT 19T 40P 1.00ID KWY	2
5	01-02-0050	Sprocket #40 21T 1.0000 in Bore Type B	1
6	01-02-0065	Sprocket #40 30T 1.0000 Bore Type B	1
7	01-03-0003	BRG FLG MNT 1.000ID 2BOLT	5
8	01-04-0001	CHAIN RLR #40 49IN LONG	1
9	01-04-0004	#40 CONNECTING LINK	1
10	01-10-0004	KEY .250 X 1.00 CS	3
11	05-06-0028	WDMT,CHAIN GRD DAF CS	1
12	05-07-0111	WDMT DAF FEED BOX CS	1
13	05-07-0836	ASSY DAF HOPP W LID AND SW	1
14	05-08-0045	WDMT MTR MNT BRKT DAF CS	1
15	05-08-0048	WDMT,AUGER TBG ADJ DAF CS	1
16	05-08-0522	WDMT DAF PADDLE	8
17	05-10-1895	DAF PANEL MOUNT PLATE CS	1
18	05-10-2036	WSHR 1IN OD 9/16IN SQ CS	2
19	05-10-4423	GSKT DAF HSG	1
20	05-11-0136	SLV DAF CALB	1
21	05-11-0467	DAF DRV SHAFT CS THD PADDLES	2
22	05-11-0468	TUBE DAF DSCHG CS 84LG .375 SLOT	1
23	05-11-0494	SHAFT ADPT 1.0 OD TO .437 HEX	1
24	06-01-0006	BOLT, .250-20 X .75 UNC ZP GRADE 5	1
25	06-01-0013	BOLT, .312-18 UNC ZP GRADE 5; 1.50" LG	4
26	06-01-0016	BOLT .375-16 X 1.00 ZP GR5	6
27	06-01-0026	BOLT CRG .500-13 X 1.75 ZP GR5	2
28	06-01-0115	BOLT CRG .375-16 X 1.00 ZP GR5	3
29	06-01-0124	BOLT FLG .375-16 X .750 ZP GR5	9
30	06-01-0127	BOLT CRG .375-16 X 1.25 ZP GR5	10
31	06-01-0189	BOLT FLG .375-16 X 1.250 ZP GR5	8
32	06-02-0003	NUT FULL .375-16 ZP GR5	10
33	06-02-0004	NUT FULL .500-13 ZP GR5	2
34	06-03-0003	NUT NYL LOCK .375-16 ZP GR5	8
35	06-03-0014	NUT LOCK FLG .375-16 ZP GR5	17

DRY ADDITIVE FEEDER

BASE ASSEMBLY (13-05-0535)

Item #	Part #	Description	Qty
36	06-03-0019	NUT LOCK FLG .3125-18 ZP GR5	4
37	06-04-0003	WSHR LOCK SPLT .375 ZP	14
38	06-04-0004	WSHR LOCK SPLT .500 ZP	2
39	06-04-0009	WSHR LOCK SPLT .250 SS 18-8	1
40	06-05-0002	WSHR FLAT .250 X .625OD SS 18-8	1
41	06-06-0042	SCRW THMB .313-18X0.75 ZP	2
42	11-05-0030	ASSY AUGER SGMT 2.0OD 2.0P 84L REMV	1

DRY ADDITIVE FEEDER
AUGUR ASSEMBLY (11-05-0030)

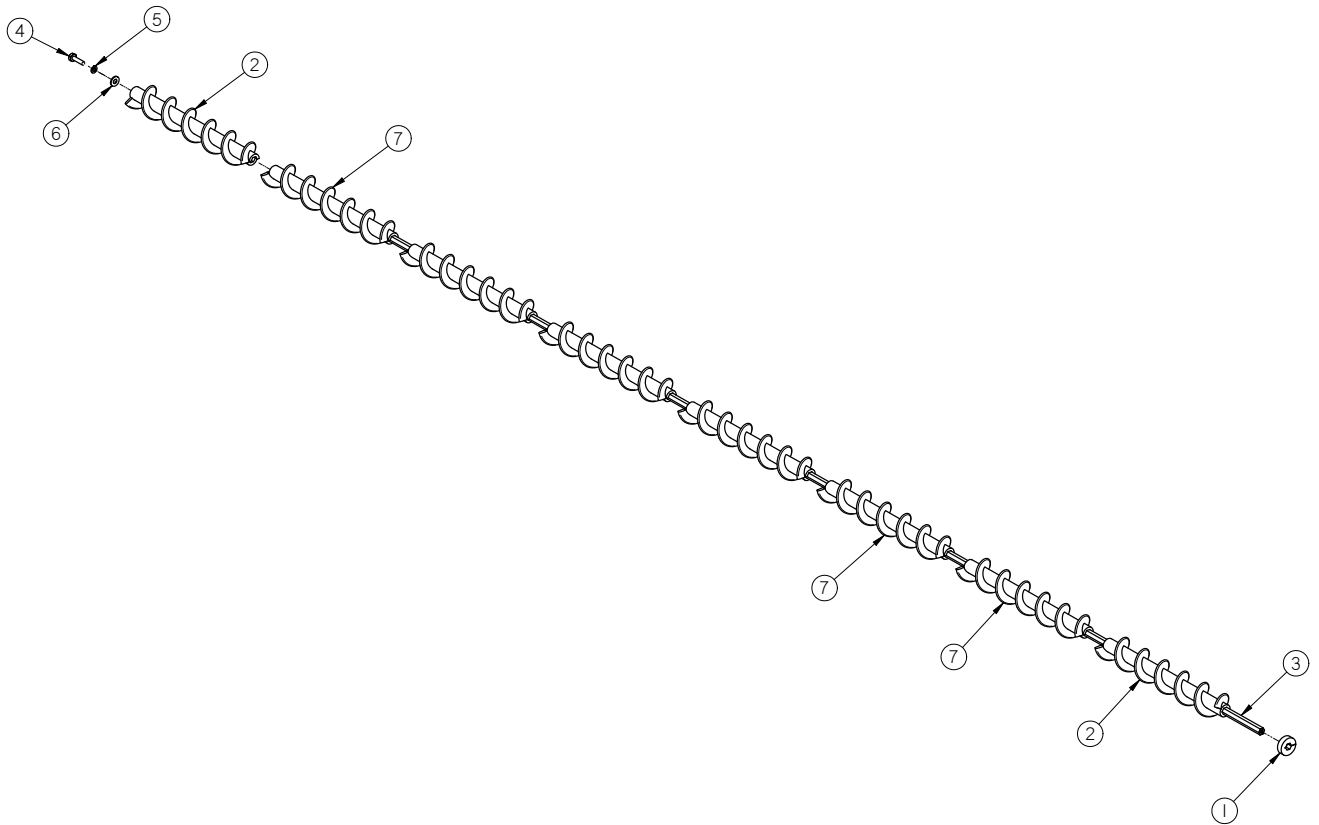

Item #	Part #	Description	Qty
1	01-05-0029	SHAFT CLR .4375 HEX SPLIT	1
2	05-11-0131	AUGER SGMT END 2.0 OD HDPE	2
3	05-11-0495	SHAFT DAF SGMT HEX DRV CS 84LG REMV	98.50 IN
4	06-01-0051	BOLT, .250-20 X 1.00 UNC 316 SS	1
5	06-04-0009	WSHR LOCK SPLT .250 SS 18-8	1
6	06-05-0002	WSHR FLAT .250 X .625OD SS 18-8	1
7	11-05-0008	AUGER SGMT HDPE 2.0OD 2.0P 12.0LG	6

DRY ADDITIVE FEEDER

DRY ADDITIVE FEEDER BASE & 120V PANEL ASSEMBLY (13-05-0373)

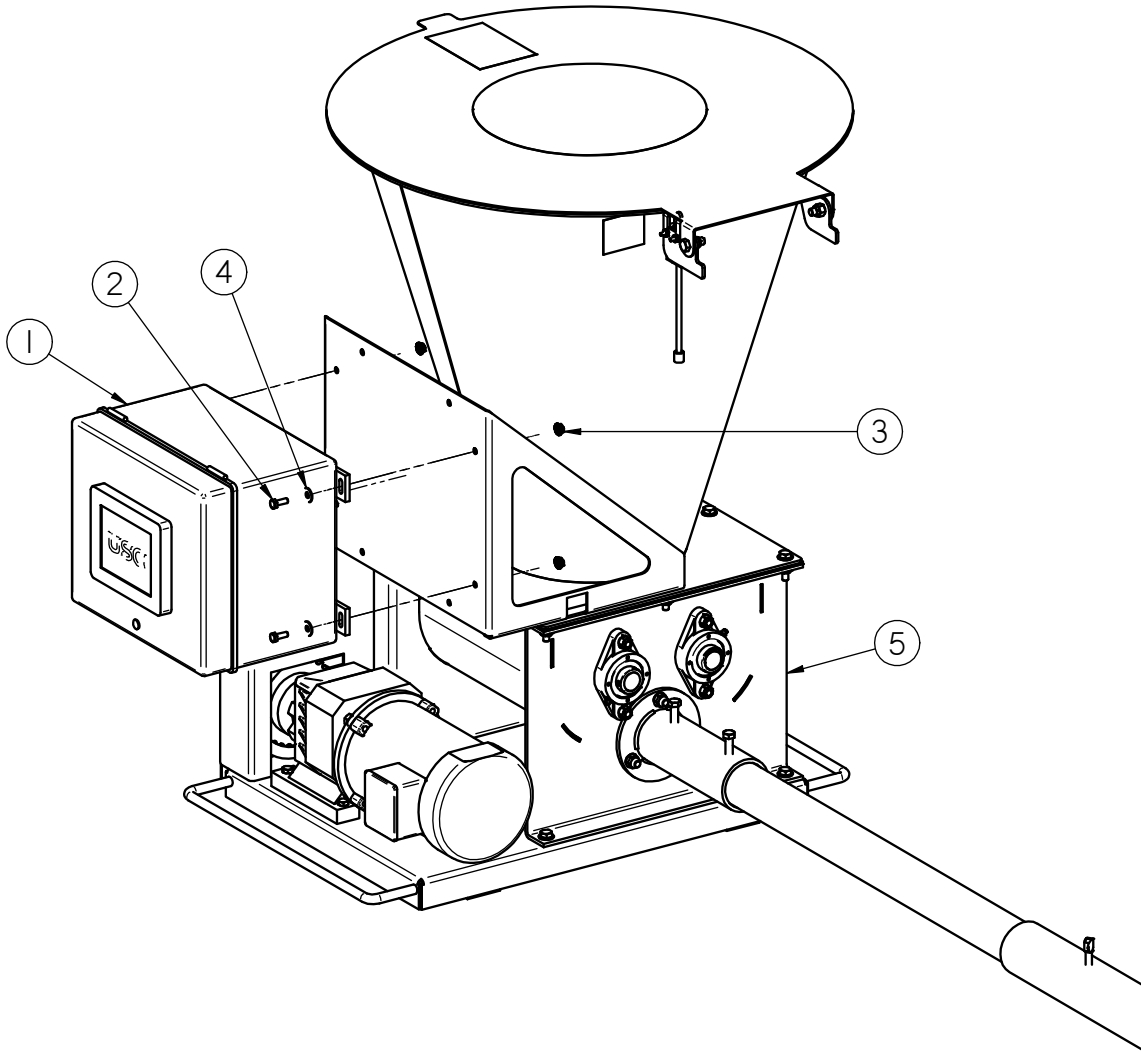

Item #	Part #	Description	Qty
1	03-12-0492	PNL CNTL MNL DAF WITH HMI 120V	1
2	06-01-0006	BOLT, .250-20 X .75 UNC ZP GRADE 5	4
3	06-03-0013	NUT, LOCK, FLG .250-20 ZP SERRATED	4
4	06-05-0001	WASHER, FLAT .250	4
5	13-05-0535	DAF 2046 CS 84IN TUBE BASE	1

DRY ADDITIVE FEEDER

DRY ADDITIVE FEEDER 120V TOP ASSEMBLY (13-05-0375)

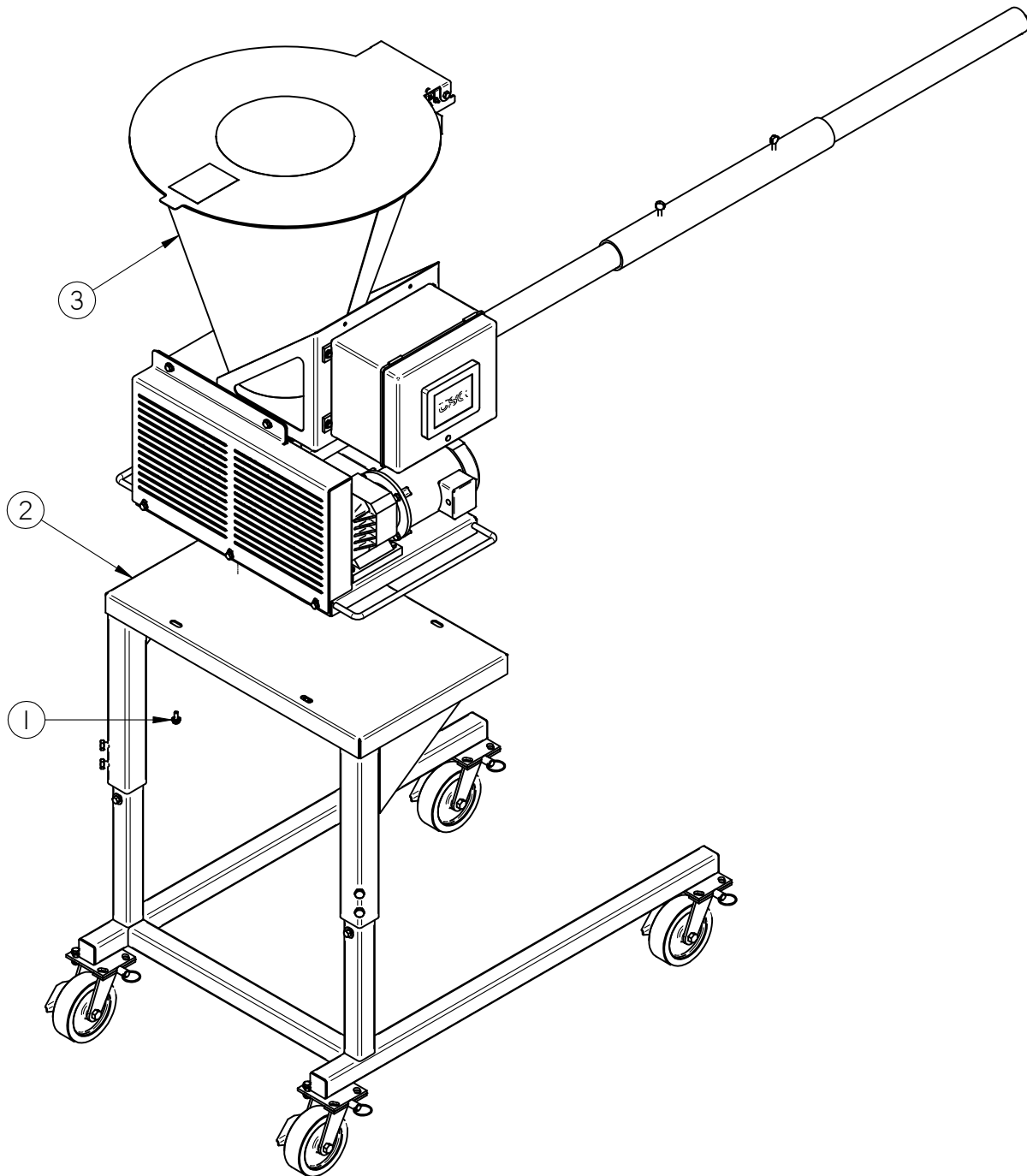

Item #	Part #	Description	Qty
1	06-01-0124	BOLT FLG .375-16 X .750 ZP GR5	4
2	13-05-0060	ASSY ADJ SUPP FRM DAF CS	1
3	13-05-0373	DAF 2046 CS 84IN REMV TUBE	1

DRY ADDITIVE FEEDER

DRY ADDITIVE FEEDER BASE & 220V PANEL ASSEMBLY (13-05-0525)

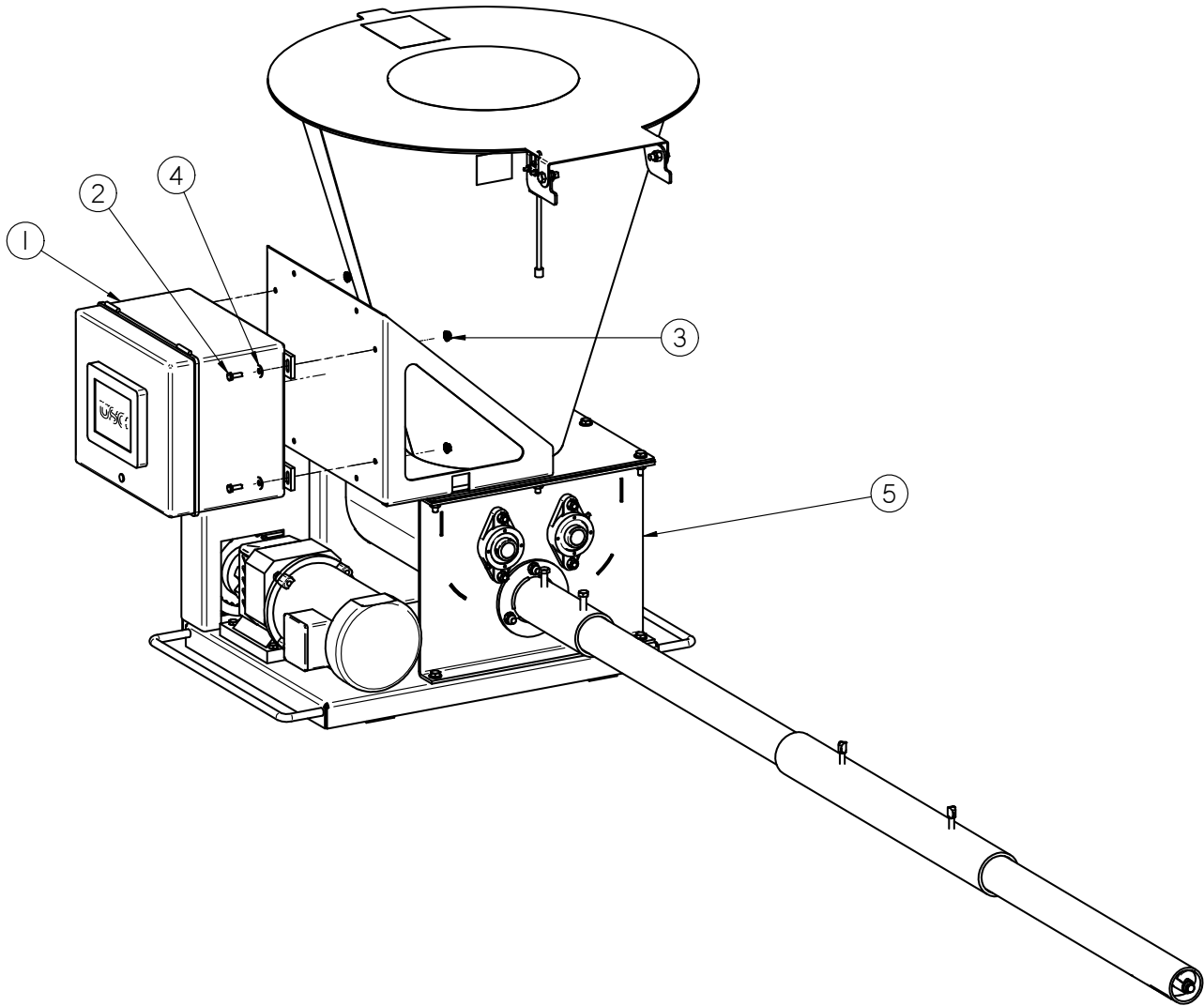

Item #	Part #	Description	Qty
1	03-12-0520	PNL CNTL MNL DAF WITH HMI 220V	1
2	06-01-0006	BOLT, .250-20 X .75 UNC ZP GRADE 5	4
3	06-03-0013	NUT, LOCK, FLG .250-20 ZP SERRATED	4
4	06-05-0001	WASHER, FLAT .250	4
5	13-05-0535	DAF 2046 CS 84IN TUBE BASE	1

DRY ADDITIVE FEEDER

DRY ADDITIVE FEEDER 220V TOP ASSEMBLY (13-05-0526)

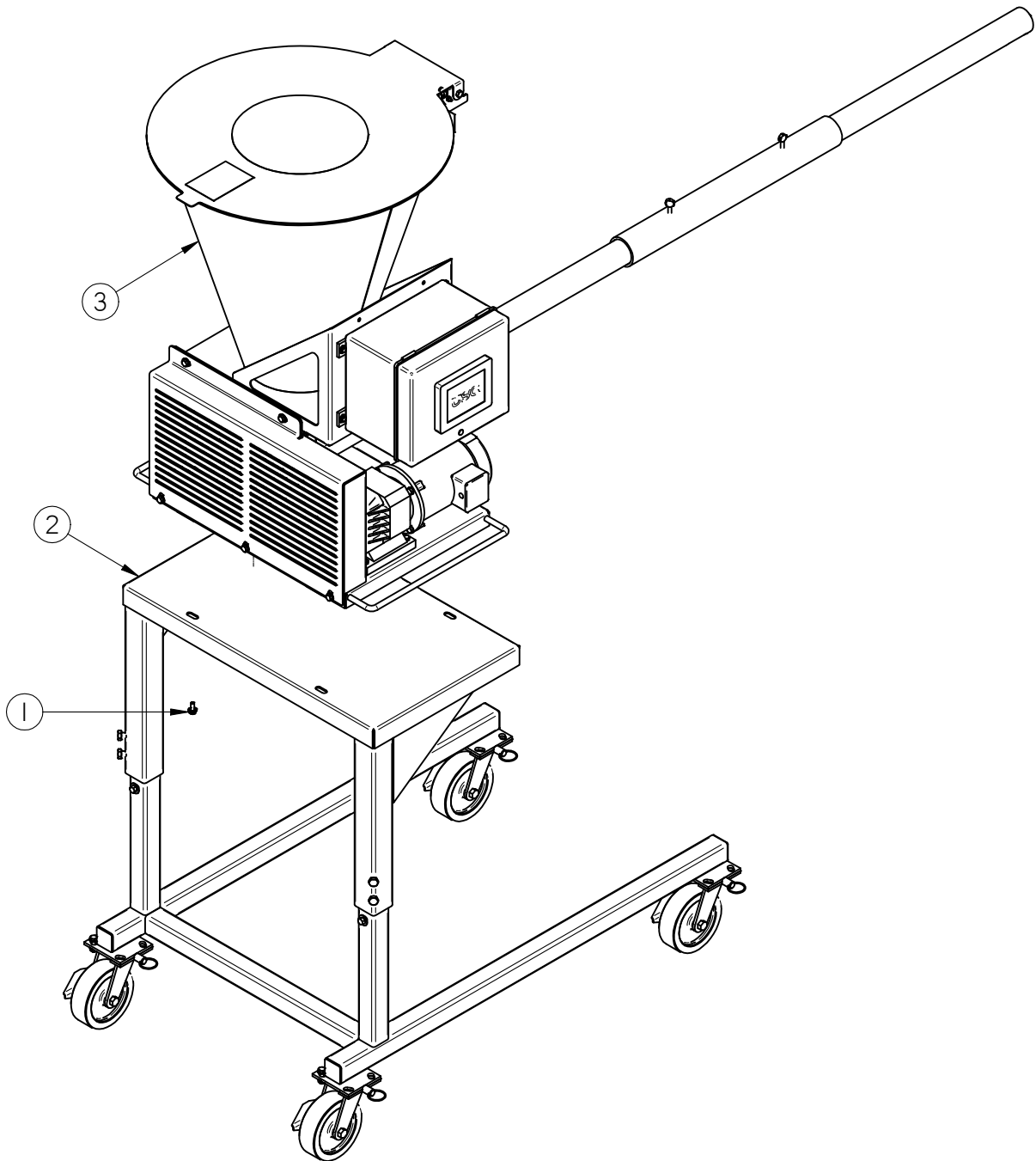

Item #	Part #	Description	Qty
1	06-01-0124	BOLT FLG .375-16 X .750 ZP GR5	4
2	13-05-0060	ASSY ADJ SUPP FRM DAF CS	1
3	13-05-0525	DAF 2046 CS 84IN TUBE 220V 1PH	1

DRY ADDITIVE FEEDER

2046 120 INCH BASE ASSEMBLY (13-05-0643)

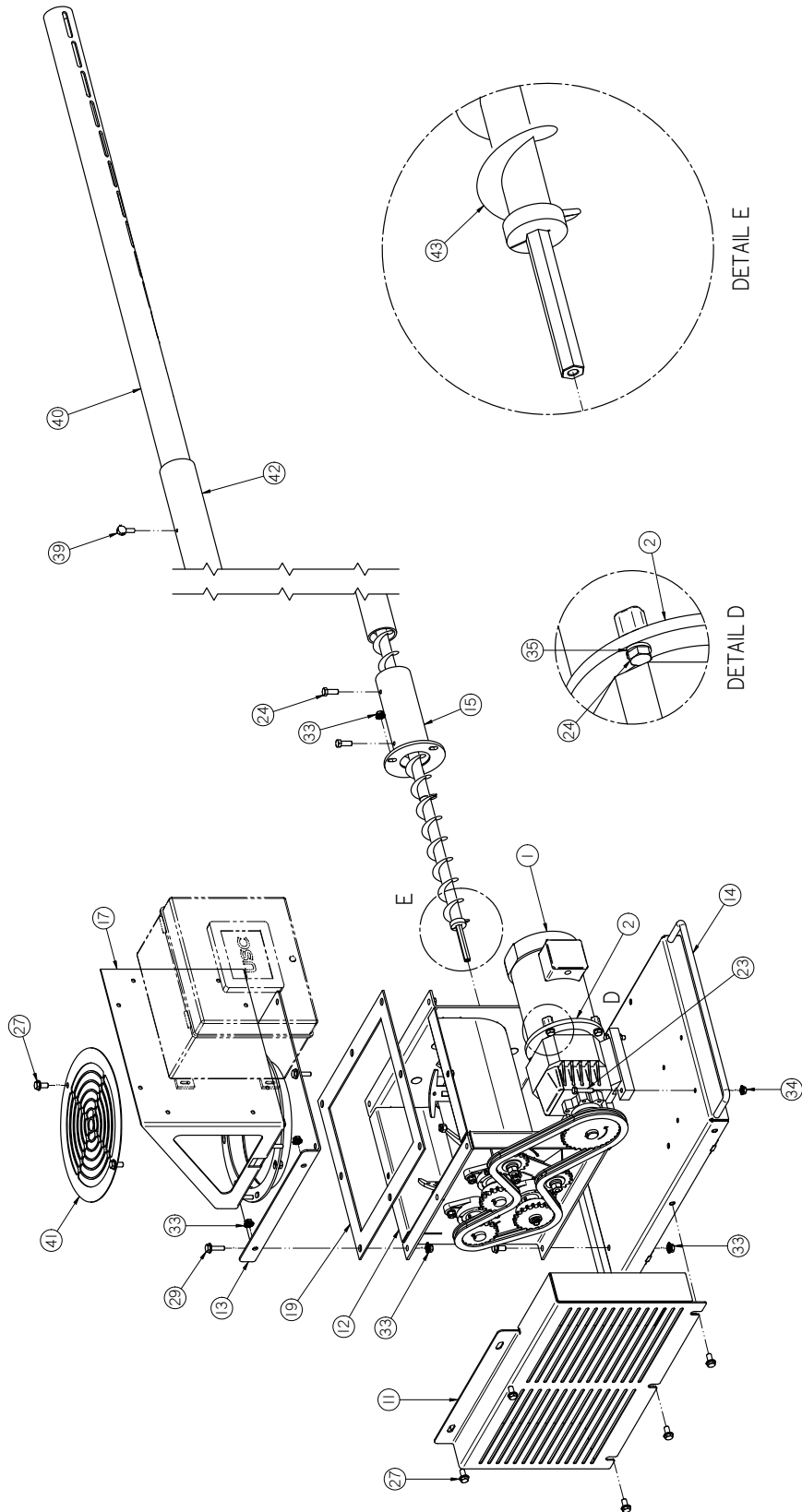

DRY ADDITIVE FEEDER

2046 120 INCH BASE ASSEMBLY (13-05-0643)

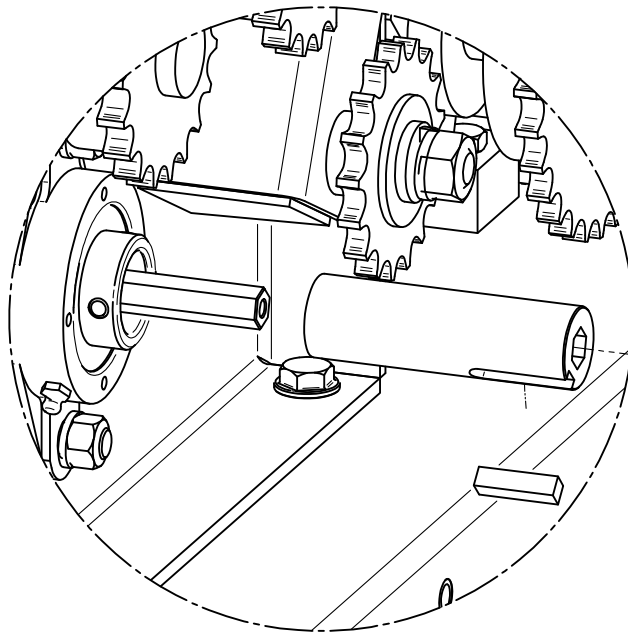
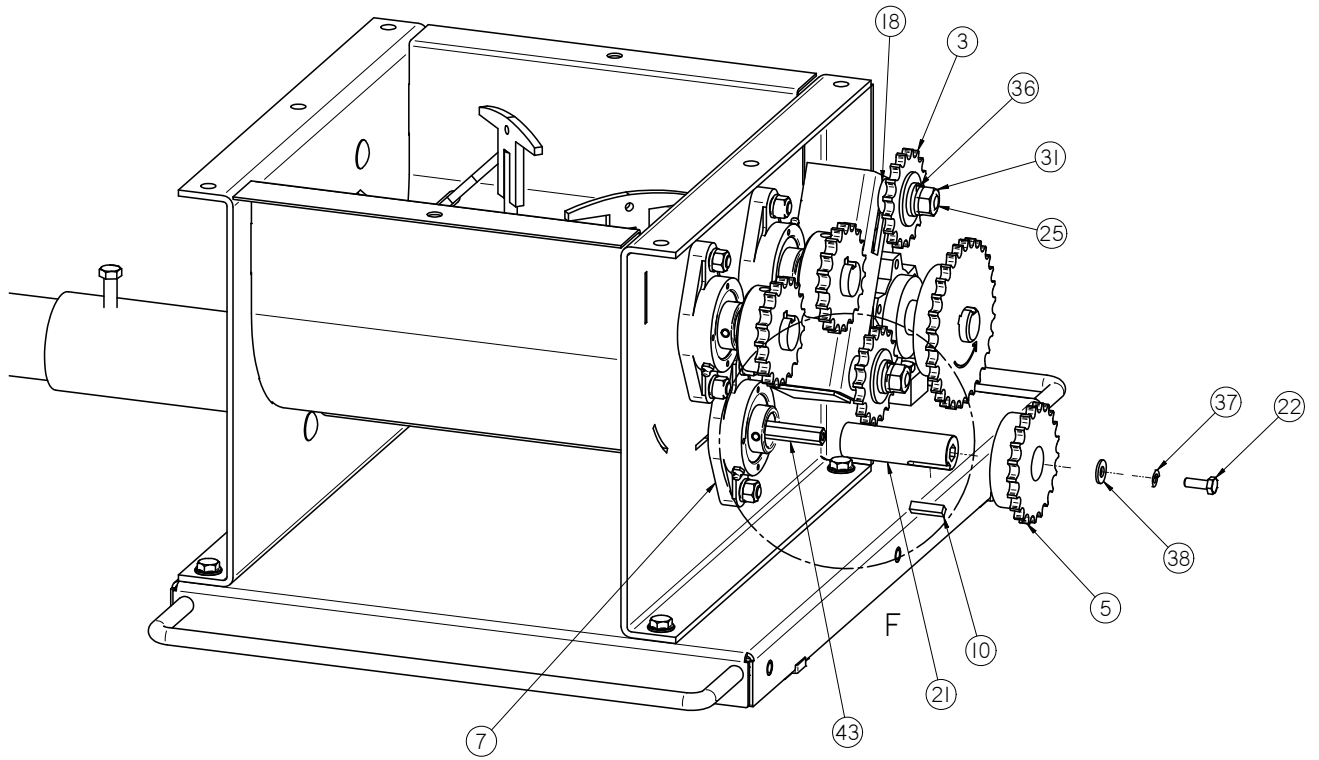

DETAIL F

DRY ADDITIVE FEEDER

2046 120 INCH BASE ASSEMBLY (13-05-0643)

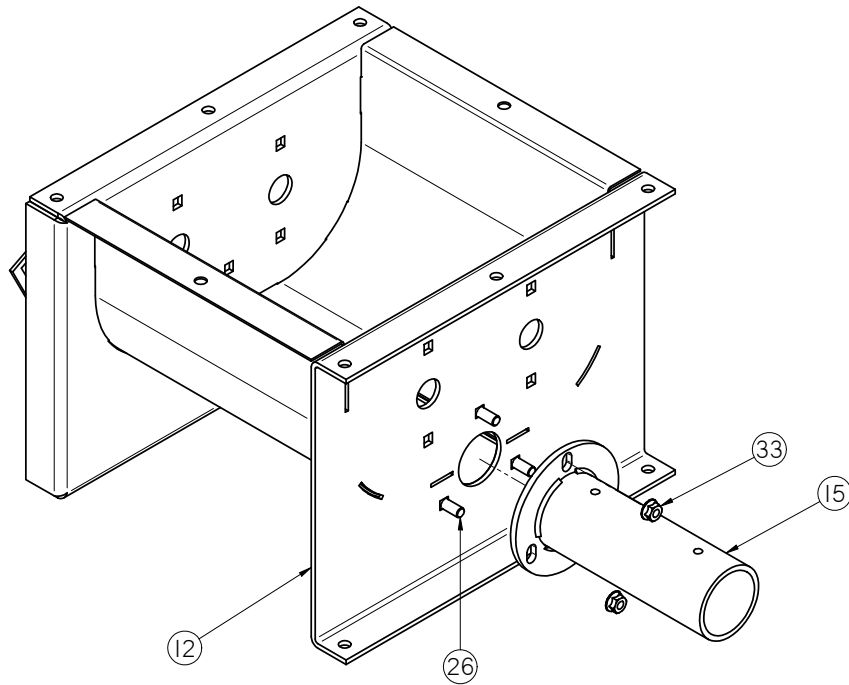
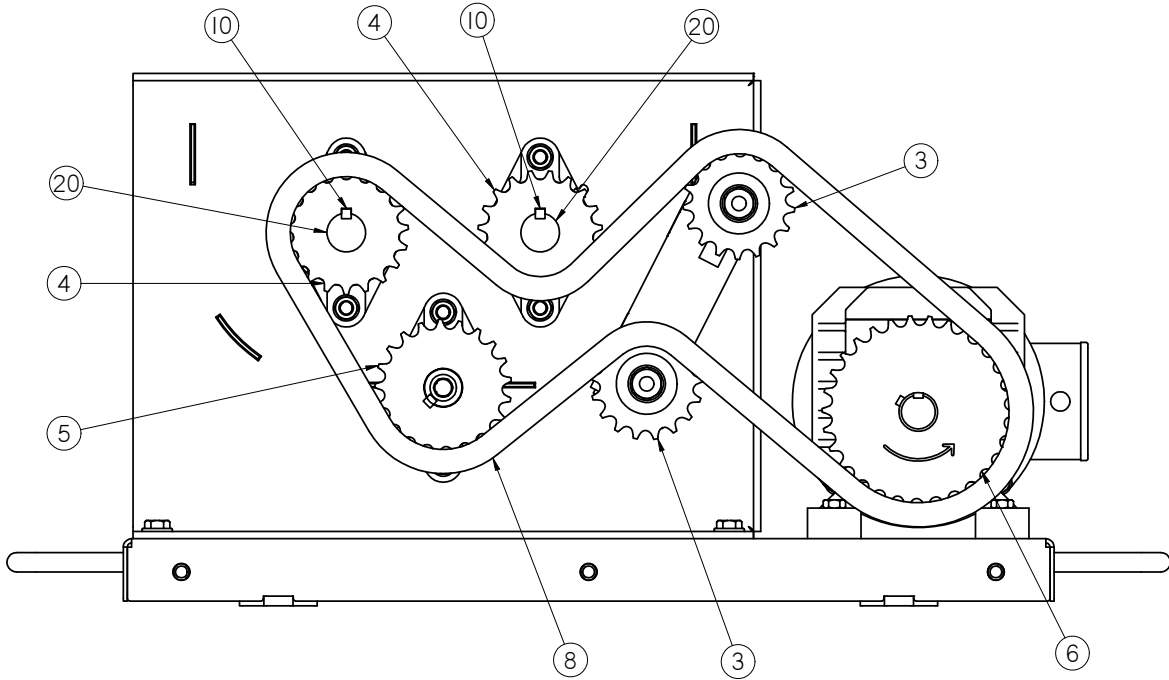

DRY ADDITIVE FEEDER

2046 120 INCH BASE ASSEMBLY (13-05-0643)

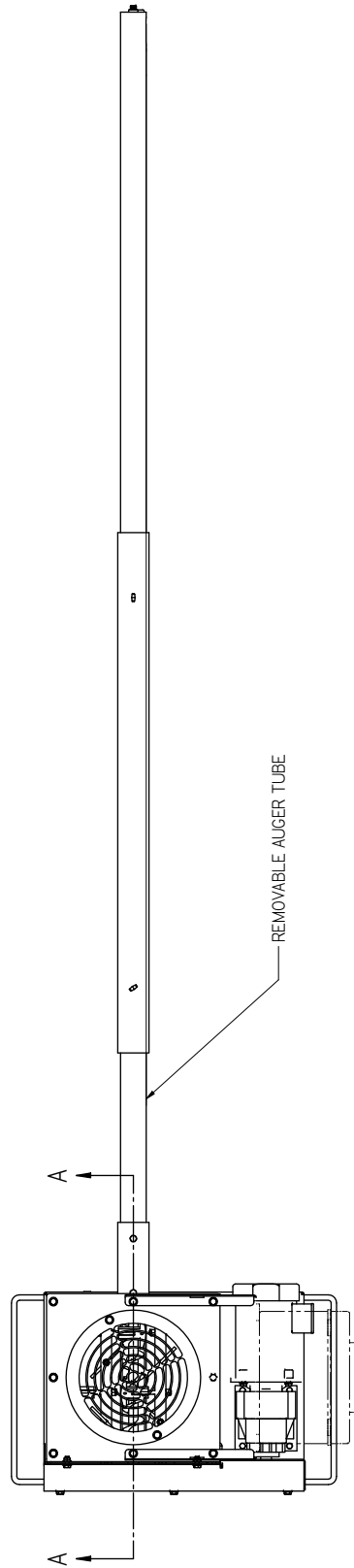

DRY ADDITIVE FEEDER

2046 120 INCH BASE ASSEMBLY (13-05-0643)

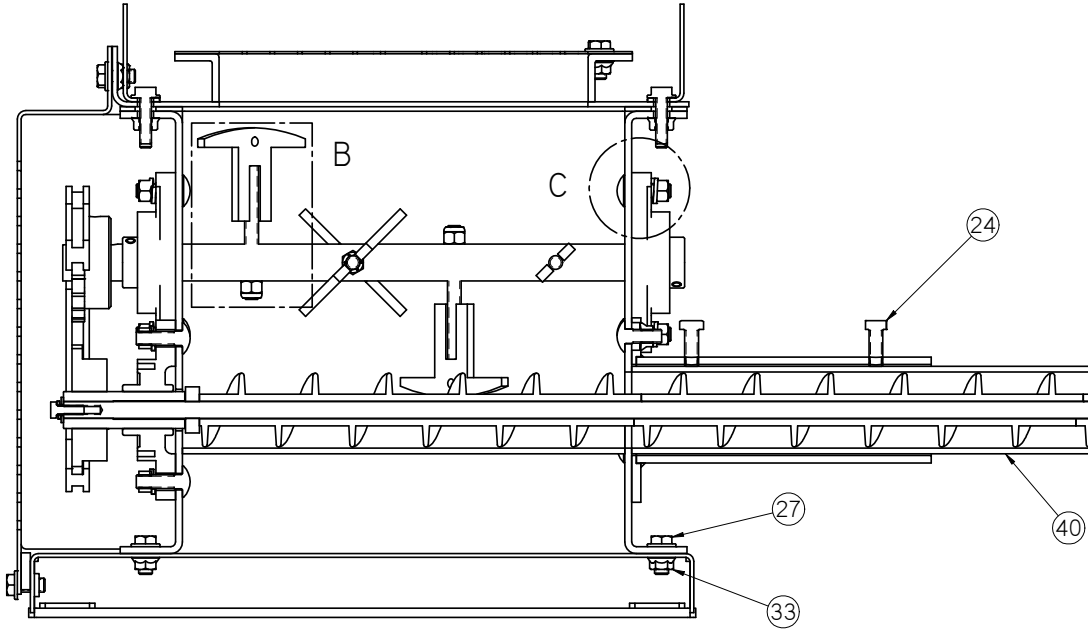

SECTION A-A

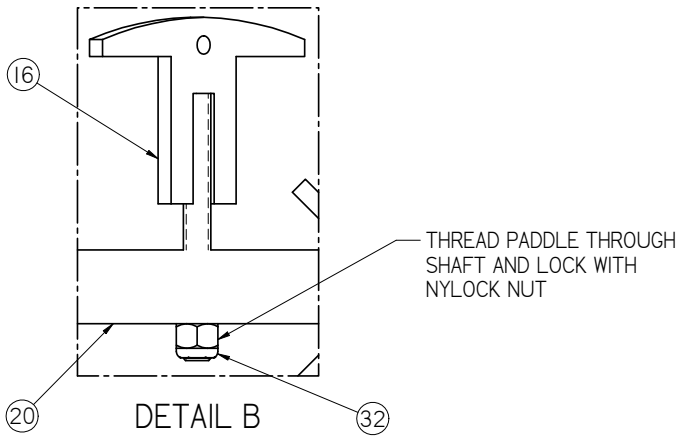

DETAIL B

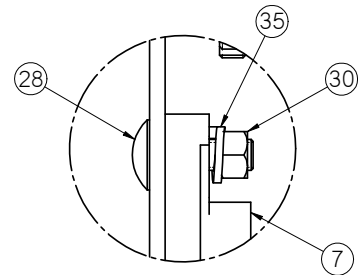

DETAIL C

Item #	Part #	Description	Qty
1	01-01-0087	MTR .5HP 1725RPM S56C 3PH INDY	1
2	01-01-0109	GBOX 56C FR 38.37:1 GR 46 RPM OUT	1
3	01-02-0001	SPKT 17T 40P .500ID IDLER	2
4	01-02-0003	SPKT 19T 40P 1.00ID KWY	2
5	01-02-0050	Sprocket #40 21T 1.0000 in Bore Type B	1
6	01-02-0065	Sprocket #40 30T 1.0000 Bore Type B	1
7	01-03-0003	BRG FLG MNT 1.000ID 2BOLT	5
8	01-04-0001	CHAIN RLR #40 49IN LONG	1

DRY ADDITIVE FEEDER

2046 120 INCH BASE ASSEMBLY (13-05-0643)

Item #	Part #	Description	Qty
9	01-04-0004	#40 CONNECTING LINK	1
10	01-10-0004	KEY .250 X 1.00 CS	3
11	05-06-0028	WDMT,CHAIN GRD DAF CS	1
12	05-07-0111	WDMT DAF FEED BOX CS	1
13	05-07-0962	WDMT DAF HPPR ATTACH	1
14	05-08-0045	WDMT MTR MNT BRKT DAF CS	1
15	05-08-0048	WDMT,AUGER TBG ADJ DAF CS	1
16	05-08-0522	WDMT DAF PADDLE	8
17	05-10-1895	DAF PANEL MOUNT PLATE CS	1
18	05-10-2036	WSHR 1IN OD 9/16IN SQ CS	2
19	05-10-4423	GSKT DAF HSG	1
20	05-11-0467	DAF DRV SHAFT CS THD PADDLES	2
21	05-11-0494	SHAFT ADPT 1.0 OD TO .437 HEX	1
22	06-01-0006	BOLT, .250-20 X .75 UNC ZP GRADE 5	1
23	06-01-0013	BOLT, .312-18 UNC ZP GRADE 5; 1.50" LG	4
24	06-01-0016	BOLT .375-16 X 1.00 ZP GR5	6
25	06-01-0026	BOLT CRG .500-13 X 1.75 ZP GR5	2
26	06-01-0115	BOLT CRG .375-16 X 1.00 ZP GR5	3
27	06-01-0124	BOLT FLG .375-16 X .750 ZP GR5	11
28	06-01-0127	BOLT CRG .375-16 X 1.25 ZP GR5	10
29	06-01-0189	BOLT FLG .375-16 X 1.250 ZP GR5	8
30	06-02-0003	NUT FULL .375-16 ZP GR5	10
31	06-02-0004	NUT FULL .500-13 ZP GR5	2
32	06-03-0003	NUT NYL LOCK .375-16 ZP GR5	8
33	06-03-0014	NUT LOCK FLG .375-16 ZP GR5	19
34	06-03-0019	NUT LOCK FLG .3125-18 ZP GR5	4
35	06-04-0003	WSHR LOCK SPLT .375 ZP	14
36	06-04-0004	WSHR LOCK SPLT .500 ZP	2
37	06-04-0009	WSHR LOCK SPLT .250 SS 18-8	1
38	06-05-0002	WSHR FLAT .250 X .625OD SS 18-8	1
39	06-06-0042	SCRW THMB .313-18X0.75 ZP	2
40	105A88	TUBE DAF DSCHG ALUM 120LG .375 SLOT	1
41	105A89	PADDLE GAURD	1
42	105A8A	SLV DAF CALB 48"L	1
43	11-05-0034	ASSY AUGER SGMT 2.0OD 120L REMV	1

DRY ADDITIVE FEEDER

2046 120 INCH AUGER SEGMENT ASSEMBLY (11-05-0034)

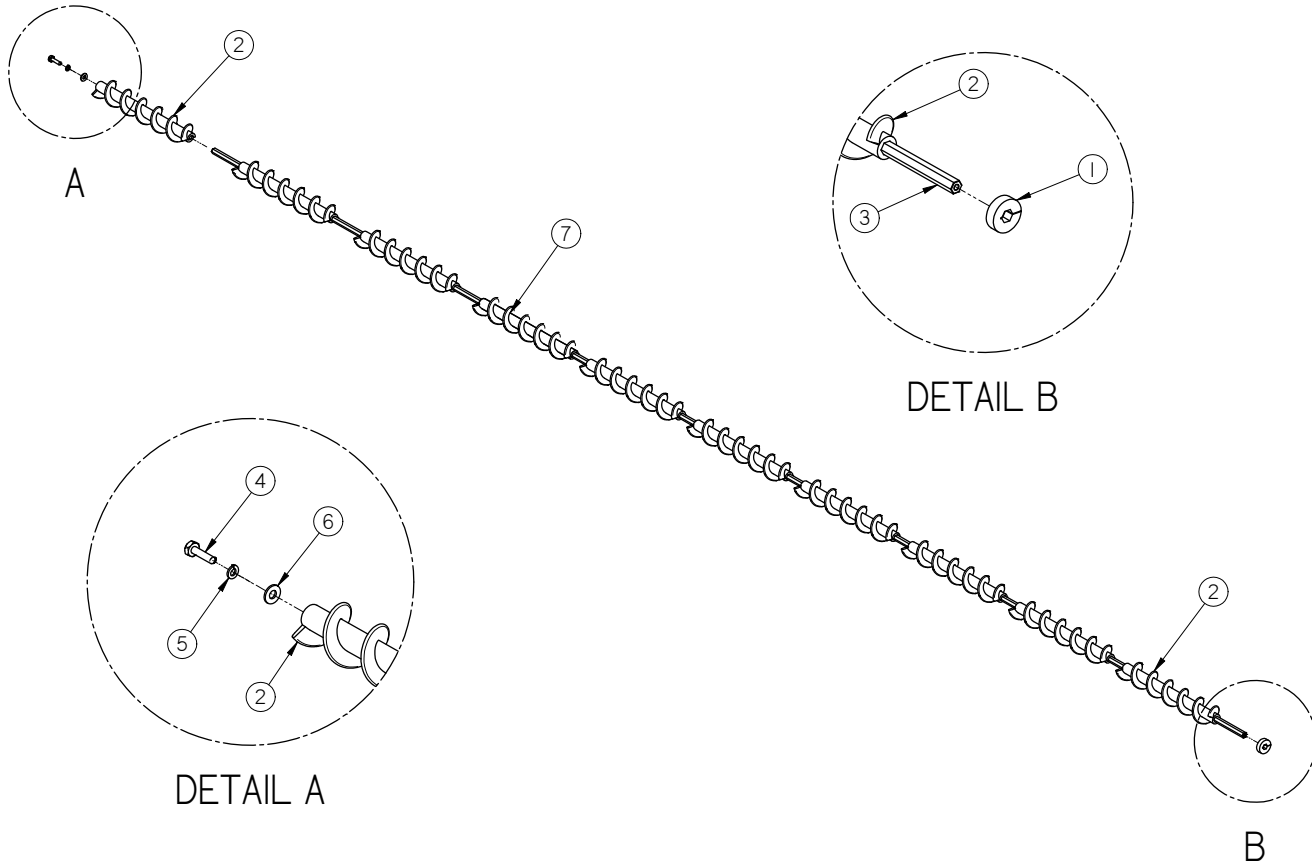

Item #	Part #	Description	Qty
1	01-05-0029	SHAFT CLR .4375 HEX SPLIT	1
2	05-11-0131	AUGER SGMT END 2.0 OD HDPE	2
3	05-11-0516	SHAFT DAF SGMT HEX CS 120LG REMV	1
4	06-01-0051	BOLT, .250-20 X 1.00 UNC 316 SS	1
5	06-04-0009	WSHR LOCK SPLT .250 SS 18-8	1
6	06-05-0002	WSHR FLAT .250 X .625OD SS 18-8	1
7	11-05-0008	AUGER SGMT HDPE 2.0OD 2.0P 12.0LG	9

2046 120 INCH AUGER ASSEMBLY (13-05-0651)

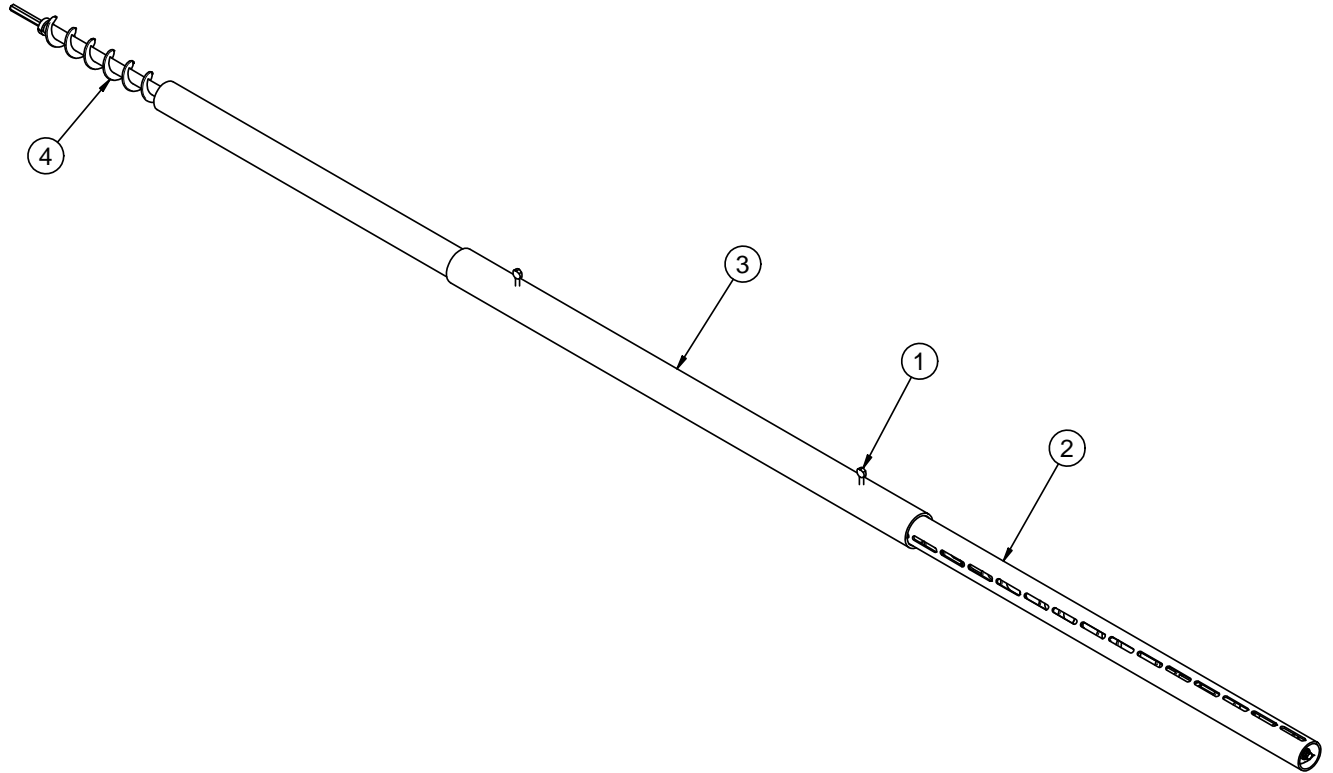

Item #	Part #	Description	Qty
1	06-06-0042	SCRW THMB .313-18X0.75 ZP	2
2	105A88	TUBE DAF DSCHG ALUM 120LG .375 SLOT	1
3	105A8A	SLV DAF CALB 48"L	1
4	11-05-0034	ASSY AUGER SGMT 2.0OD 120L REMV	1

DRY ADDITIVE FEEDER

2046 120 INCH BASE & 120V PANEL ASSEMBLY (13-05-0644)

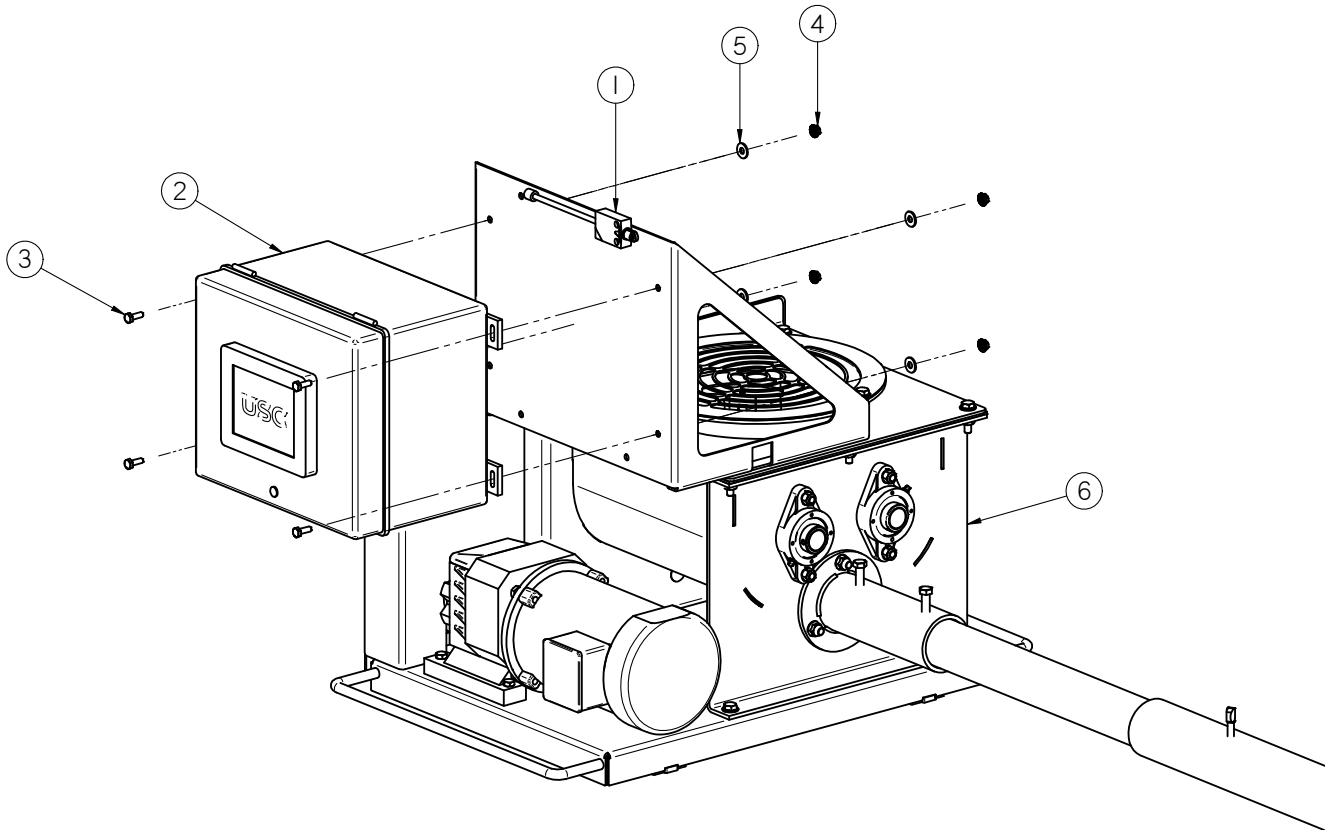

Item #	Part #	Description	Qty
1	03-10-0156	SW LMT AB RLR PLNGR 440P-ARPS11D5	1
2	03-12-0492	PNL CNTL MNL DAF WITH HMI 120V	1
3	06-01-0006	BOLT, .250-20 X .75 UNC ZP GRADE 5	4
4	06-03-0013	NUT, LOCK, FLG .250-20 ZP SERRATED	4
5	06-05-0001	WASHER, FLAT .250	4
6	13-05-0643	DAF 2046 CS 120IN TUBE BASE	1

DRY ADDITIVE FEEDER

2046 120 INCH TOP ASSEMBLY (13-05-0645)

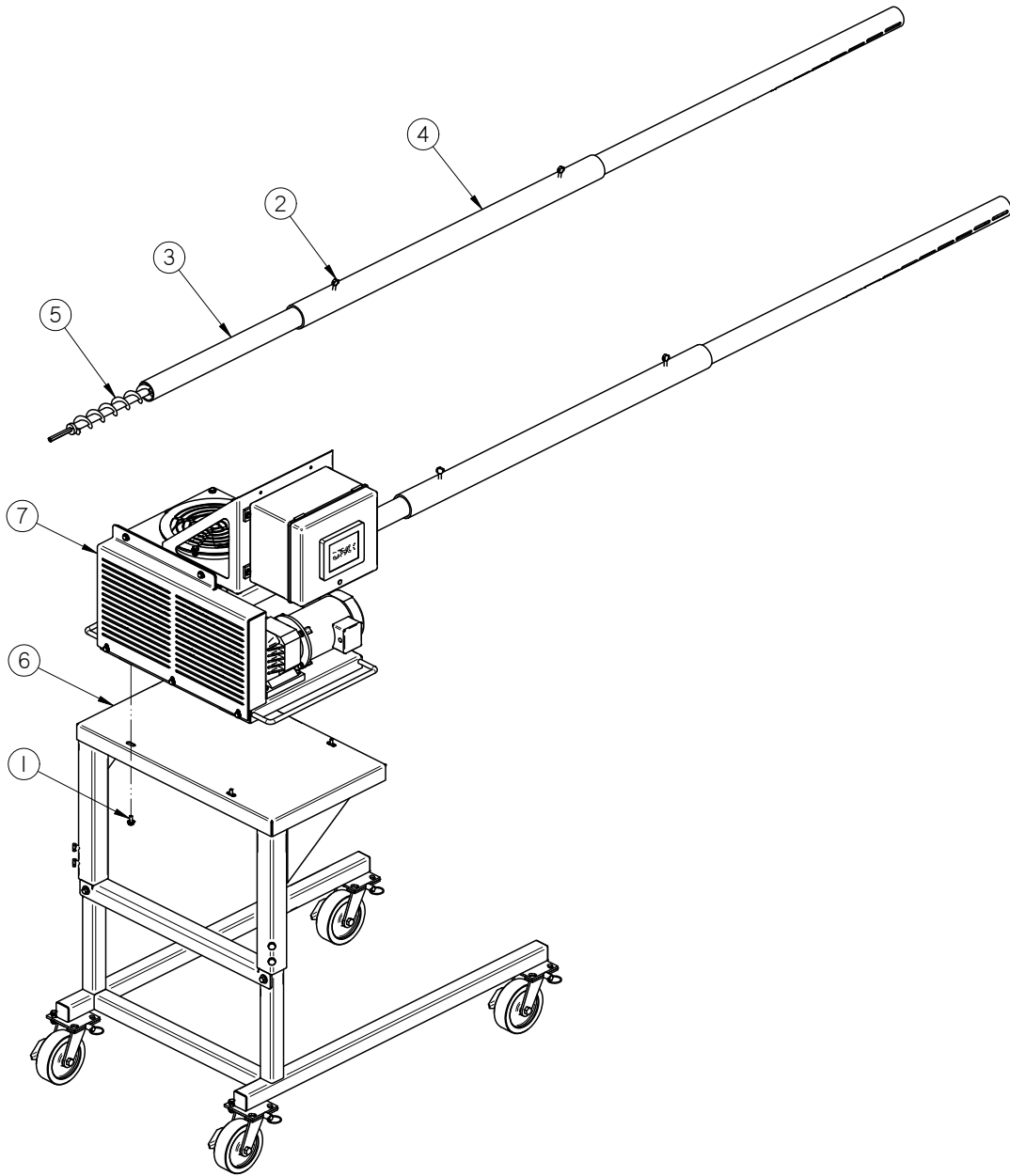

Item #	Part #	Description	Qty
1	06-01-0124	BOLT FLG .375-16 X .750 ZP GR5	4
2	06-06-0042	SCRW THMB .313-18X0.75 ZP	2
3	105A88	TUBE DAF DSCHG ALUM 120LG .375 SLOT	1
4	105A8A	SLV DAF CALB 48"L	1
5	11-05-0034	ASSY AUGER SGMT 2.00D 120L REMV	1
6	13-05-0060	ASSY ADJ SUPP FRM DAF CS	1
7	13-05-0644	DAF 2046 CS 120IN REMV TUBE	1

DRY ADDITIVE FEEDER

NOTES:

LIMITED WARRANTY

SECTION J

USC, LLC, (Manufacturer) warrants its seed treating equipment as follows:

1. **Limited Warranty:** Manufacturer warrants that the Products sold hereunder will be free from defects in material and workmanship for a period of 18 months from date of shipment. If the Products do not conform to this Limited Warranty during the warranty period, Buyer shall notify Manufacturer in writing of the claimed defects and demonstrate to Manufacturer satisfaction that said defects are covered by this Limited Warranty. If the defects are properly reported to Manufacturer within the warranty period, and the defects are of such type and nature as to be covered by this warranty, Manufacturer shall, at its expense, furnish replacement Products or, at Manufacturer's option, replacement parts for the defective products. Shipping and installation of the replacement Products or replacement parts shall be at the Buyer's expense.

2. **Other Limits:** THE FOREGOING IS IN LIEU OF ALL OTHER WARRANTIES, EXPRESSED OR IMPLIED, INCLUDING BUT NOT LIMITED TO THE IMPLIED WARRANTIES OF MERCHANTABILITY AND FITNESS FOR A PARTICULAR PURPOSE. Manufacturer does not warrant against damages or defects arising from improper installation (where installation is by persons other than Manufacturer), against defects in products or components not manufactured by Manufacturer, or against damages resulting from such non-Manufacturer made products or components. Manufacturer passes on to the Buyer the warranty it received (if any) from the maker of such non-Manufacturer made products or components. This warranty also does not apply to Products upon which repairs and / or modifications have been effected or attempted by persons other than pursuant to written authorization by Manufacturer. This includes any welding on equipment which could damage electrical components. Manufacturer does not warrant against casualties or damages resulting from misuse and / or abuse of Products, improper storage or handling, acts of nature, effects of weather, including effects of weather due to outside storage, accidents, or damages incurred during transportation by common carrier.

3. **Exclusive Obligation:** THIS WARRANTY IS EXCLUSIVE. The sole and exclusive obligation of Manufacturer shall be to repair or replace the defective Products in the manner and for the period provided above. Manufacturer shall not have any other obligation with respect to the Products or any part thereof, whether based on contract, tort, strict liability or otherwise. Under no circumstances, whether based on this Limited Warranty or otherwise, shall Manufacturer be liable for lost profits, lost revenue, lost sales (whether direct or indirect damages), incidental, special, punitive, indirect or consequential damages.

4. **Other Statements:** Manufacturer's employees or representatives' oral or other written statements do not constitute warranties, shall not be relied upon by Buyer, and are not a part of the contract for sale or this limited warranty.

5. **Return Policy:** Approval is required prior to returning goods to Manufacturer. A restocking fee will apply.

6. **Entire Obligation:** This Limited Warranty states the entire obligation of Manufacturer with respect to the Products. If any part of this Limited Warranty is determined to be void or illegal, the remainder shall remain in full force and effect.

US / Canada Non-Exclusive 2016

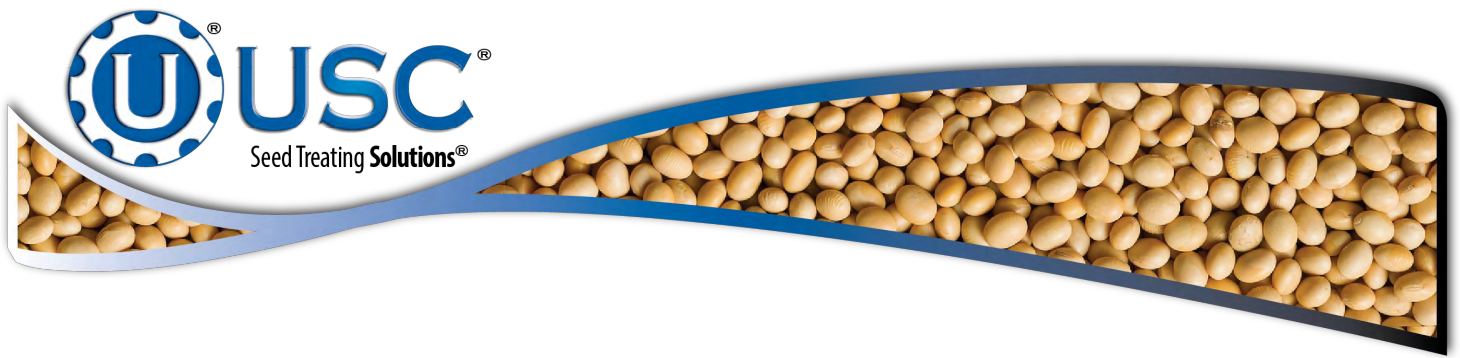

USC, LLC

2320 124th road

Sabetha, KS 66534

PHONE: (785) 431-7900

FAX: (785) 431-7950

EMAIL: sales-team@uscllc.com

WEB: www.uscllc.com
