

LPV WEIGH BELT SEED TREATER

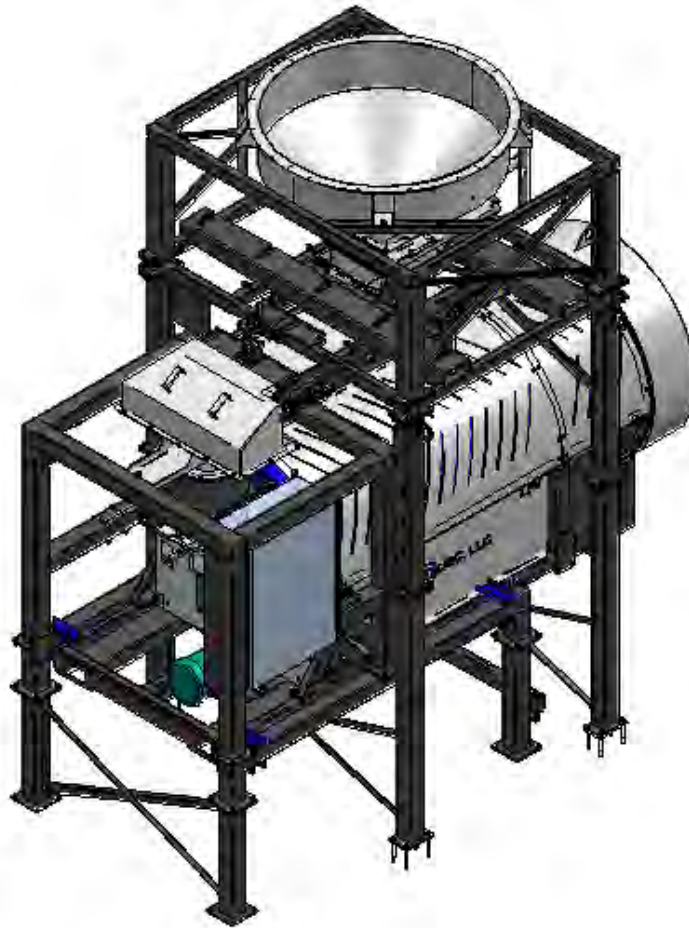

Operators Manual

Document: TD-09-06-1051 Revision: C Effective Date: 10-2020



INTRODUCTION

Thank you for choosing USC, LLC for your equipment needs. We appreciate your business and will work diligently to ensure that you are satisfied with your choice.

OVERVIEW

The purpose of this manual is to provide you with the basic information needed to operate and maintain the LPV Seed Treater. It does not hold USC, LLC liable for any accidents or injuries that may occur.

The technical information provided in this document is based on extensive testing under controlled conditions at the USC research and development facility. This information is given without guarantee as the conditions of operation and storage of the equipment are beyond our control. Variables such as temperature, humidity, viscosity of chemical products and changes in seed size or variety may all effect the accuracy of application and seed coverage. Periodically check the equipment calibration while treating and make adjustments as required. This will insure the optimum seed coverage.

RECEIVING YOUR EQUIPMENT

As soon as the equipment is received, it should be carefully inspected to make certain that it has sustained no damage during shipment and that all items listed on the packing list are accounted for. If there is any damage or shortages, the purchaser must immediately notify USC, LLC. Ownership passes to purchaser when the unit leaves the USC, LLC. premises. The purchaser is responsible for unloading and mounting all components of the equipment.

Document the serial number of the machine for future reference. The serial number is located on the frame to the right of the Control Panel.

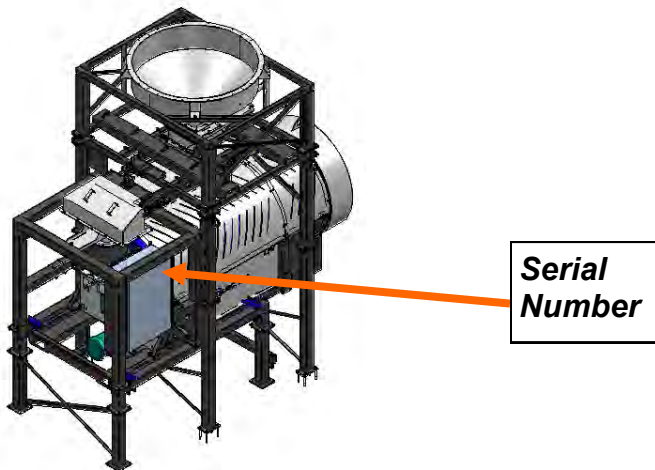

SERIAL NUMBER: _____

TABLE OF CONTENTS

<u>Section</u>	<u>Contents</u>	<u>Page #</u>
Section A	Safety Instructions	4
Section B	Installation	19
	LPV Treater Set-up.....	20
	Weigh Belt Set-up.....	24
Section C	Mechanical Operation	30
	LPV Treater with Weigh Belt Overview	30
	Weigh Belt Overview	31
	Weigh Belt with Atomizer Chamber Overview.....	33
	Rotating Drum Overview	35
Section D	Electrical Operation	36
	Weigh Belt Transport / Operating Positions.....	38
	Weigh Belt Operation / Calibration.....	39
Section E	Troubleshooting	41
Section F	Maintenance	43
	Proximity Switch Adjustment Guide	44
Section G	Storage	51
Section H	Limited Warranty	54

SECTION **SAFETY INSTRUCTIONS**

A

Every year accidents in the work place maim, kill and injure people. Although it may be impossible to prevent all accidents, with the right combination of training, operating practices, safety devices, and operator vigilance, the number of accidents can be significantly reduced. The purpose of this section is to educate equipment users about hazards, unsafe practices, and recommended hazard avoidance techniques.

If any of the required regularly scheduled maintenance is located above the reach of the operator, they should follow the companies normal safe practices of reaching that particular height, utilizing the companies specified equipment and following normal safety precautions.

When working with treatment chemicals, operators should always wear protective gloves, safety glasses, and follow the companies safety precautions in the case of any spillage or operator contamination.

SAFETY WORDS AND SYMBOLS

It is very important that operators and maintenance personnel understand the words and symbols that are used to communicate safety information. Safety words, their meaning and format, have been standardized for U.S. manufacturers and published by the American National Standards Institute (ANSI). The European Community (E.C.) has adopted a different format based on the International Standards Organization (I.S.O.) and applicable machinery directives. Both formats are presented below. Graphic symbols are not standardized, but most manufacturers will use some variation of the ones seen in this manual.

MOTS ET SYMBOLES SÉCURITÉ

Il est très important que les opérateurs et le personnel d'entretien à comprendre les mots et les symboles qui sont utilisés pour communiquer des informations de sécurité. Mots de sécurité, de leur signification et le format, ont été normalisés pour les fabricants américains et publié par l' American National Standards Institute (ANSI). La Communauté européenne (CE) a adopté un format différent sur la base de l'Organisation internationale de normalisation (ISO) et des directives de machines applicables. Les deux formats sont présentés ci-dessous. Les symboles graphiques ne sont pas standardisés, mais la plupart des fabricants utilisent une variante de ceux observés dans ce manuel.



Indicates an imminently hazardous situation which, if not avoided, **will** result in death or serious injury.



Indique une situation extrêmement dangereuse qui, si pas évitée, entraînera la mort ou des blessures graves.



Indicates a potentially hazardous situation which, if not avoided, **could** result in death or serious injury.



Indique une situation potentiellement dangereuse qui, si pas évitée, pourrait entraîner la mort ou des blessures graves.



Indicates a potentially hazardous situation which, if not avoided, **may** result in minor or moderate injury and/or property damage.



Indique une situation potentiellement dangereuse qui, si pas évitée, peut entraîner des blessures mineures ou modérées et / ou des dommages.



Provides additional information that the operator needs to be aware of to avoid a potentially hazardous situation.



Fournit des informations supplémentaires que l'opérateur doit être conscient de d'éviter une situation potentiellement dangereuse.



Notice is used to notify people of important installation, operation or maintenance information which is not hazard related.



Avis est utilisé pour informer les gens des informations de maintenance qui ne est pas danger lié importante installation, l'exploitation ou.



Mandatory Lockout Power Symbol. Disconnect, lockout and tagout electrical and other energy sources before inspecting, cleaning or performing maintenance on this panel.

Symbole de puissance verrouillage obligatoire. Débranchez, de verrouillage et de déconsignation énergie électrique et d'autres sources avant d'inspecter, de nettoyage ou de la maintenance de ce panneau.



International Safety Alert Symbol. The exclamation point (!) surrounded by a yellow triangle indicates that an injury hazard exists. However, it does not indicate the seriousness of potential injury. The exclamation point (!) is also used with the DANGER, WARNING and CAUTION symbols so the potential injury is indicated.

Sécurité Symbole International Alert . Le point d'exclamation (!) Entouré par un triangle jaune indique que un risque de blessure existe . Cependant, il ne indique pas la gravité des blessures potentielles. Le point d'exclamation (!) Est également utilisé avec les symboles DANGER, AVERTISSEMENT et ATTENTION de sorte que le risque de blessure est indiqué.



Electrocution Hazard Symbol. This symbol indicates that an electrocution hazard exists. Serious injury or death could result from contacting high voltage.

Symbole de danger d'électrocution . Ce symbole indique qu'un danger d'électrocution existe. Des blessures graves ou la mort pourraient résulter de contact haute tension.



International Electrocution Hazard. This symbol indicates that an electrocution hazard exists. Serious injury or death could result from contacting high voltage.

Danger d'électrocution international. Ce symbole indique qu'un danger d'électrocution existe. Des blessures graves ou la mort pourraient résulter de contact haute tension.

LOCKOUT / TAGOUT PROCEDURES

Lockout/Tagout is the placement of a lock/tag on an energy isolating device in accordance with an established procedure. When taking equipment out of service to perform maintenance or repair work, always follow the lockout / tagout procedures as outlined in OSHA Standard 1910.147. This standard "requires employers to establish a program and utilize procedures for affixing appropriate lockout devices or tagout devices to energy isolating devices and to otherwise disable machines or equipment to prevent unexpected energizing, start-up, or release of stored energy in order to prevent injury to employees."

LES PROCEDURES DE VERROUILLAGE / ETIQUETAGE

Verrouillage / étiquetage est le placement d'un verrouillage / tag sur un dispositif d'isolement de l'énergie conformément à une procédure établie. Lors de la prise hors service des équipements pour effectuer la maintenance ou de réparation, toujours suivre les procédures de verrouillage / débranchement comme indiqué dans la norme OSHA 1910.147. Cette norme "oblige les employeurs à établir un programme et appliquer des procédures pour la fixation des dispositifs de verrouillage appropriés ou des dispositifs déconsignation à l'énergie dispositifs d'isolement et d' autre machines ou équipements désactiver pour éviter énergisant inattendu, start-up, ou la libération de l'énergie stockée dans le but de prévenir les blessures aux employés."

EMERGENCY STOP

There is an Emergency Stop push button on all LPV Seed Treaters which is located on the Treater Control Panel. The LPV Automated Treater has an additional Emergency Stop pushbutton on the Main Control Panel. Actuators of emergency stop shall be colored RED. The background immediately around the device actuator shall be colored YELLOW. The actuator pushbutton operated device shall be of the palm or mushroom head type.



ARRET D'URGENCE

Il ya un bouton-poussoir d'arrêt d'urgence sur tous les traiteurs de semences LPV qui est situé sur le Panneau de configuration Traiteur. Le LPV automatisé Traiteur dispose d'une autre arrêt d'urgence bouton poussoir sur le panneau de commande principal. Actionneurs de freinage d'urgence doivent être de couleur rouge. Le fond immédiatement autour de l'actionneur de l'appareil doit être de couleur JAUNE. Le dispositif actionné actionneur de bouton-poussoir doit être de la paume ou champignons type de tête.



DANGER! RISK OF ELECTRIC SHOCK AND ARC FLASH

Avoid any alteration to the equipment. Alterations may produce dangerous situations, where serious injury or death may occur. This equipment shall be installed in accordance with local installation codes and applicable regulations which should be carefully followed in all cases. Authorities having jurisdiction should be consulted before installations are made. Owners/operators are responsible for knowing what requirements, hazards, and precautions exist with this equipment. Owners/operators are responsible for informing all personnel associated with the equipment and all who are in the general area of the equipment, the requirements, hazards, and precautions that exist with this equipment. Electrical equipment should be installed, operated, serviced, and maintained only by qualified personnel. A qualified person is one who has skills and knowledge related to the construction and operation of electrical equipment and its installation and has received safety training to recognize and avoid the hazards involved. Only appropriately trained persons who are familiar with and understand the contents of this manual and all other pertinent product documentation are authorized to work on and/or with this product. Owners/operators must ensure that all authorized persons have sufficient technical training, knowledge, and experience and be able to foresee and detect potential hazards that may be caused by using the product, by changing the settings and by the mechanical, electrical, and electronic equipment of the entire system in which the product is used. All persons working on and with the product must be fully familiar with all applicable standards, directives, and accident prevention regulations when performing such work. Servicing and maintaining the equipment should only occur if the equipment is deenergized and properly locked out and tagged out. If it is unfeasible to service or maintain the equipment while deenergized, the following standards shall be referenced to ensure safe practices are being followed and proper PPE is being used: 29 CFR § 1910.333 and 29 CFR § 1910.137. No responsibility is assumed by USC, LLC for any consequences arising out of the use of this material.



DANGER! RISQUE DE CHOC ÉLECTRIQUE ET D'ARC ÉLECTRIQUE

Évitez toute modification de l'équipement. Les modifications peuvent produire des situations dangereuses, pouvant entraîner des blessures graves ou la mort. Cet équipement doit être installé conformément aux codes d'installation locaux et aux réglementations applicables qui doivent être scrupuleusement respectés dans tous les cas. Les autorités compétentes doivent être consultées avant la réalisation des installations. Les propriétaires / opérateurs sont responsables de connaître les exigences, les dangers et les précautions associés à cet équipement. Les propriétaires / opérateurs sont responsables d'informer tout le personnel associé à l'équipement et tous ceux qui se trouvent dans la zone générale de l'équipement, les exigences, les dangers et les précautions qui existent avec cet équipement. L'équipement électrique doit être installé, utilisé, réparé et entretenu uniquement par du personnel qualifié. Une personne qualifiée est une personne qui possède des compétences et des connaissances liées à la construction et au fonctionnement du matériel électrique et à son installation et qui a reçu une formation en matière de sécurité pour reconnaître et éviter les risques encourus. Seules les personnes correctement formées qui connaissent et comprennent le contenu de ce manuel et toute autre documentation pertinente sur le produit sont autorisées à travailler sur et / ou avec ce produit. Les propriétaires / opérateurs doivent s'assurer que toutes les personnes autorisées ont une formation, des connaissances et une expérience techniques suffisantes et être en mesure de prévoir et de détecter les dangers potentiels pouvant être causés par l'utilisation du produit, en modifiant les paramètres et par les équipements mécaniques, électriques et électroniques. de l'ensemble du système dans lequel le produit est utilisé. Toutes les personnes travaillant sur et avec le produit doivent être parfaitement familiarisées avec toutes les normes, directives et réglementations de prévention des accidents applicables lors de l'exécution de ces travaux. L'entretien et la maintenance de l'équipement ne doivent avoir lieu que si l'équipement est hors tension et correctement verrouillé et étiqueté. S'il est impossible de réparer ou d'entretenir l'équipement lorsqu'il est hors tension, les normes suivantes doivent être référencées pour s'assurer que les pratiques de sécurité sont suivies et que des EPI appropriés sont utilisés: 29 CFR § 1910.333 et 29 CFR § 1910.137. Aucune responsabilité n'est assumée par USC, LLC pour les conséquences découlant de l'utilisation de ce matériel.

CONTROLLED STOP

This is the stopping of machine motion by reducing the electrical command signal to 0 (zero) once the stop signal has been recognized.

ARRET CONTROLÉ

Ce est l'arrêt du mouvement de la machine en réduisant le signal de commande électrique à 0 (zéro) dès que le signal d'arrêt a été reconnue.

HAZARD REVIEW

RISQUE EXAMEN



Electrocution Hazard

Electrocution accidents are most likely to occur during maintenance of the electrical system or when working on or near exposed high voltage wiring. This hazard does not exist when the electrical power has been disconnected, properly locked, and tagged out.

Risque d'électrocution

Les accidents d'électrocution sont les plus susceptibles de se produire lors de la maintenance du système électrique ou pour travailler sur ou à proximité du câblage haute tension exposé. Ne existe pas ce danger lorsque l'alimentation électrique a été déconnecté, bien verrouillé et étiquetés sur.



! WARNING

Automatic Start Hazard

This equipment may be controlled by an automated system and may start without warning. Failure to properly disconnect, lockout, and tagout all energy sources of remotely controlled equipment creates a very hazardous situation and could cause injury or even death. PLEASE STAY CLEAR AND BE ALERT.

Démarrer danger automatique

! AVERTISSEMENT

Cet équipement peut être contrôlé par un système automatisé et peut démarrer sans avertissement. Sources de l'équipement contrôlé à distance non débranché correctement, lock-out, et tous déconsignation énergie crée une situation très dangereuse et pourrait causer des blessures ou même la mort. Se IL VOUS PLAÎT rester à l'écart et d'être vigilant.

LPV WEIGH BELT SEED TREATER

YOU are responsible for the **SAFE** operation and maintenance of your USC, LLC equipment . **YOU** must ensure that you and anyone else who is going to operate, maintain or work around the equipment be familiar with the operating and maintenance procedures and related **SAFETY** information contained in this manual. This manual will take you step-by-step through your working day and alert you to good safety practices that should be adhered to while operating the equipment

Remember, **YOU** are the key to safety. Good safety practices not only protect you, but also the people around you. Make these practices a working part of your safety program. Be certain that **EVERYONE** operating this equipment is familiar with the recommended operating and maintenance procedures and follows all the safety precautions. Most accidents can be prevented. Do not risk injury or death by ignoring good safety practices.

- Equipment owners must give operating instructions to operators or employees before allowing them to operate the machine, and at least annually thereafter per OSHA (Occupational Safety and Health Administration) regulation 1928.57.
- The most important safety device on this equipment is a **SAFE** operator. It is the operator's responsibility to read and understand **ALL** Safety and Operating instructions in the manual and to follow them. All accidents can be avoided.
- A person who has not read and understood all operating and safety instructions is not qualified to operate the machine. An untrained operator exposes himself and bystanders to possible serious injury or death.
- Do not modify the equipment in any way. Unauthorized modification may impair the function and/or safety and could affect the life of the equipment.
- Think SAFETY! Work SAFELY!

GENERAL SAFETY

1. Read and understand the operator's manual and all safety labels before operating, maintaining, adjusting or unplugging the equipment .
2. Only trained persons shall operate the equipment . An untrained operator is not qualified to operate the machine.
3. Have a first-aid kit available for use should the need arise, and know how to use it.



LPV WEIGH BELT SEED TREATER

4. Provide a fire extinguisher for use in case of an accident. Store in a highly visible place.
5. Do not allow children, spectators or bystanders within hazard area of machine.
6. Wear appropriate protective gear. This includes but is not limited to:
 - A hard hat
 - Protective shoes with slip resistant soles
 - Protective goggles
 - Heavy gloves
 - Hearing protection
 - Respirator or filter mask
7. Place all controls in neutral or off, stop motor, and wait for all moving parts to stop. Then disable power source before servicing, adjusting, repairing, or unplugging.
8. Review safety related items annually with all personnel who will be operating or maintaining the equipment.



OPERATING SAFETY:

1. Read and understand the Operator's Manual and all safety labels before using.
2. Disconnect and disable electrical supply completely and wait for all moving parts to stop before servicing, adjusting, repairing or unplugging.
3. Clear the area of bystanders, especially children, before starting.
4. Be familiar with the machine hazard area. If anyone enters hazard area, shut down machine immediately. Clear the area before restarting.
5. Keep hands, feet, hair and clothing away from all moving and/or rotating parts.
6. Stay away from overhead obstructions and power lines during operation and transporting. Electrocution can occur without direct contact.
7. Do not operate machine when any guards are removed.
8. Inspect welds and repair if needed.

PLACEMENT SAFETY

1. Move only with the appropriate equipment



2. Stay away from overhead power lines when moving equipment. Electrocution can occur without direct contact.

3. Be familiar with machine hazard area. If anyone enters hazard areas, shut down machine immediately. Clear the area before restarting.

4. Operate the equipment on level ground free of debris. Anchor the equipment to prevent tipping or upending.

▲ WARNING

Before placement of the equipment, be sure that ground is reasonably level. The equipment may topple or work improperly if the ground is too uneven, damaging the equipment and / or causing personal injury.

! AVERTISSEMENT

Avant de placement de l'équipement, assurez-vous que sol est relativement plat. L'équipement peut tomber ou mal fonctionner si le sol est trop inégale, endommager l'équipement et / ou causer des blessures.

MAINTENANCE SAFETY

1. Review the operator's manual and all safety items before working with, maintaining or operating the equipment .
2. Place all controls in neutral or off, stop motors, disable power source, and wait for all moving parts to stop before servicing, adjusting, repairing or unplugging.
3. Follow good shop practices:

Keep service area clean and dry.

Be sure electrical outlets and tools are properly grounded.

Use adequate light for the job at hand.

4. Keep hands, feet, hair and clothing away from all moving and/or rotating parts.
5. Clear the area of bystanders, especially children, when carrying out any maintenance and repairs or making any adjustments.
6. Before resuming work, install and secure all guards when maintenance work is completed.
7. Keep safety labels clean. Replace any sign that is damaged or not clearly visible.



SAFETY LABELS

1. Keep safety labels clean and legible at all times.
2. Replace safety labels that are missing or have become illegible.
3. Replaced parts that displayed a safety label should also display the current label.
4. Replacement safety labels are available. Contact your authorized dealer.

How to Install Safety Labels:

- Be sure that the installation area is clean and dry.
- Be sure temperature is above 50°F (10°C).
- Decide on the exact position before you remove the backing paper.
- Remove the smallest portion of the split backing paper.
- Align the label over the specified area and carefully press the small portion with the exposed sticky backing in place.
- Slowly peel back the remaining paper and carefully smooth the remaining portion of the sign in place.
- Small air pockets can be pierced with a pin and smoothed out using the piece of label backing paper.



Located on the USC equipment you will find safety labels. Always be sure to read and follow all directions on the labels.



Situé sur l'équipement USC vous trouverez des étiquettes de sécurité. Veuillez à toujours lire et suivre toutes les instructions sur les étiquettes.



Guards provided with USC equipment are to remain in place during operation.



Gardes fournis avec des équipements USC doivent rester en place pendant le fonctionnement.

LPV WEIGH BELT SEED TREATER

Think **SAFETY!** Work **SAFELY!**

REMEMBER—If Safety Labels have been damaged, removed, become illegible, or parts replaced without safety labels, new labels must be applied. New safety labels are available from your authorized dealer..



Part # 09-02-0003



Part # 09-02-0002



Part # 09-02-0010



Part # 09-02-0001

LPV WEIGH BELT SEED TREATER

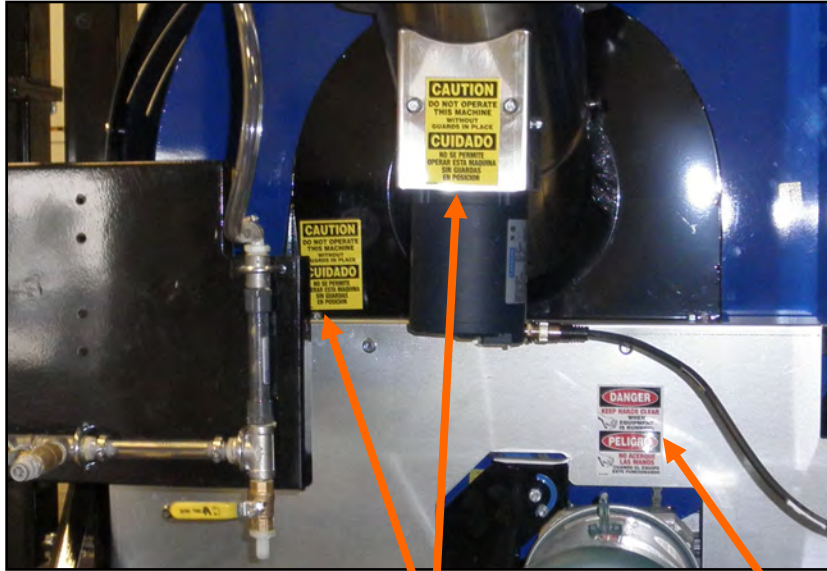

Part # 09-02-0002



Part # 09-02-0001



LPV WEIGH BELT SEED TREATER



Part # 09-02-0011

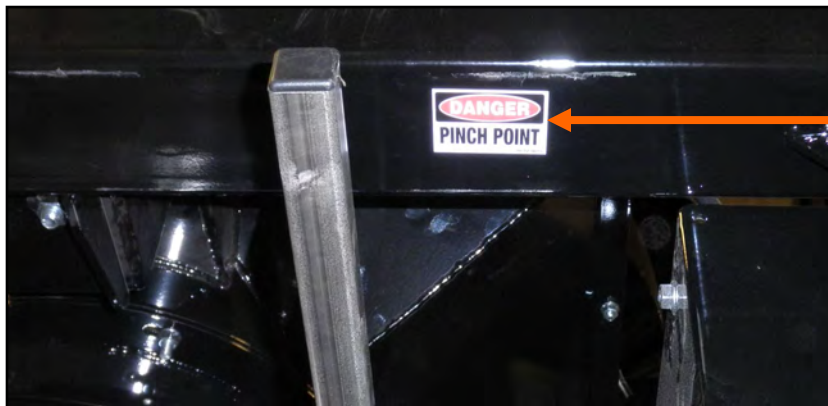
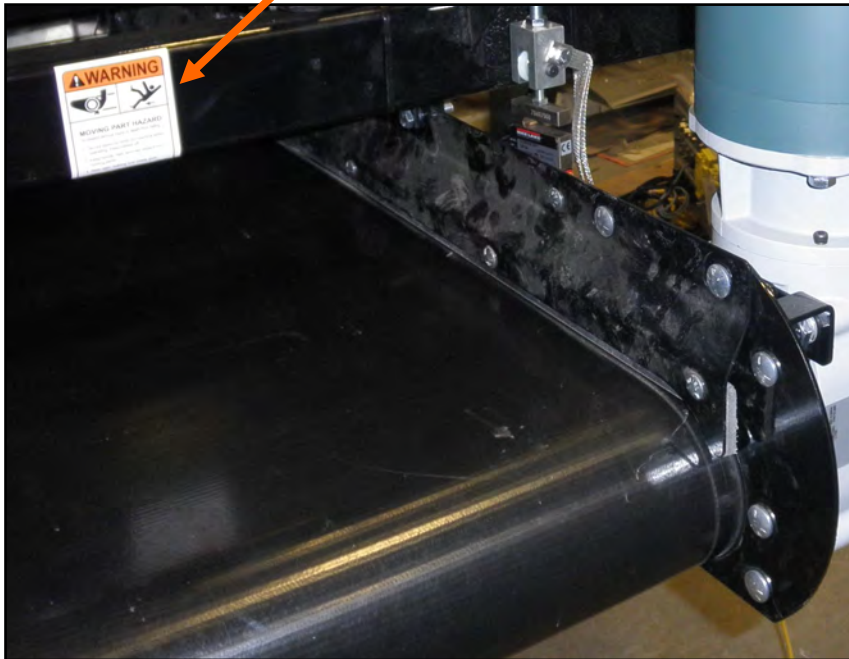

Part # 09-02-0015

LPV WEIGH BELT SEED TREATER

If any of the panels are located in the hazardous area described in the installation section (see page 19), the following criteria must be met.

1. All 120VAC connections must be hard wired to a listed IP65 rated enclosure in accordance with local electrical codes.
2. The C2D2 certifications are only valid for equipment operating at 60 HZ.
3. The approved operating temperature for this equipment is between 0°C (32°F) and 40°C (104°F).
4. All RJ45 and USB pass-through connector caps must remain closed to achieve a C2D2 rating. Hard wire these connections in accordance with local electrical codes.

The following labels and certification plates must be mounted to the outside of the control panel so that they are in plain view.

MFG. By:  USC
Max Voltage: 240V, 1PH, 60Hz
Total FLA: 61
Largest Motor: 28 Amps
Equipment Model: HV086H41500
Suitable to be used in Class II, Div 2, Group G, T4A Hazardous Locations

!!WARNING!!
DISCONNECT POWER BEFORE REMOVING COVERS. KEEP COVERS/
CONNECTIONS CLOSED WHILE CIRCUITS ARE LIVE. SEE INSTRUCTION MANUAL
!!AVERTISSEMENT!!
DÉBRANCHER L'ALIMENTATION AVANT DE RETIRER LES COUVERCLES. GARDEZ
LES COUVERCLES / CONNEXIONS FERMÉS PENDANT QUE LES CIRCUITS SONT EN
CIRCUIT. VOIR LE MANUEL D'INSTRUCTIONS

!!WARNING!!
EXPLOSION HAZARD. DO NOT REMOVE OR REPLACE CONNECT OR DISCONNECT
WHILE CIRCUIT IS LIVE UNLESS THE AREA IS FREE OF IGNITIBLE
CONCENTRATIONS.
!!AVERTISSEMENT!!
RISQUE D'EXPLOSION. NE PAS ENLEVER OU REMPLACER LA CONNEXION OU LA
DÉCONNEXION TANT QUE LE CIRCUIT EST EN CIRCUIT SAUF SI LA ZONE EST
EXEMPTÉ DE CONCENTRATIONS IGNITIABLES.



INSTALLATION**SECTION
B**

HIGH VOLTAGE ~ Always disconnect the power source before working on or near the control panel or lead wires.



HAUTE TENSION ~ Toujours débrancher la source d'alimentation avant de travailler sur ou près du panneau de commande ou les câbles.



HIGH VOLTAGE ~ Use insulated tools when making adjustments while the controls are under power.



HAUTE TENSION ~ Utilisez des outils isolés lors des réglages, tandis que les commandes sont sous tension.



Permanent installation may require additional electrical cords, chemical tubing, and air lines, since each installation is unique.



Installation permanente peut exiger cordons électriques, des tubes supplémentaires chimique, et les conduites d'air, puisque chaque installation est.

USC equipment may operate within a Group II, Division 2, Class G hazardous area which contains seed dust. If so, the equipment must be certified for use in this area. To avoid the possibility of an explosion ignited by static electricity, all USC equipment should be grounded by attaching a bonding strip to the metal frame and securing that strip to the factory ground point.

If labeled accordingly, USC products are designed to comply with CSA 22.1 for use in a Class II, Division 2, Group G environment. When connecting the USC system power cord into a power supply, first determine if the supply is also within the hazardous area where the USC system is located. If so, we recommend that the power be hard wired into the source. Do not use a standard electrical plug for this purpose. For other acceptable methods of connecting to a power source, or any other additional miscellaneous equipment to the USC system within a hazardous location, please consult CSA 22.1, Section 18-200 and 18-274. Review the appropriate section and ensure compliance with one of the options given.

When connecting to USC equipment from a remote location, and the USC equipment is in a hazardous Class II, Group G environment, customers are advised to follow the requirements within CSA 22.2 no. 25. More details may also be found in CSA 22.1 18-252 (wiring methods). There are various options covered within this section for wiring in a Class II, Group G (dust) environment. Select the best method suited for your specific location.

équipements USC peut fonctionner dans un Groupe II, Division 2, Classe G zone dangereuse qui contient la poussière des semences. Si oui, l'équipement doit être certifié pour une utilisation dans ce domaine. Pour éviter la possibilité d'une explosion enflammé par l'électricité statique, tous les équipements USC doit être mis à la terre en attachant une bande de liaison à la structure métallique et la sécurisation cette bande au point de masse du fabricant.

Si étiquetés en conséquence, les produits USC sont conçus pour être conformes à la norme CSA 22.1 pour une utilisation dans une Classe II, Division 2, Groupe G environnement. Lors du raccordement du USC alimentation du système cordon dans une alimentation, d'abord déterminer si l'offre est également dans la zone dangereuse où se trouve le système USC. Si oui, nous recommandons que le pouvoir soit câblé dans la source. Ne pas utiliser une prise électrique standard à cet effet. Pour les autres méthodes acceptables de se connecter à une source d'alimentation, ou tout autre matériel divers supplémentaire au système USC dans un endroit dangereux, se il vous plaît consulter la norme CSA 22.1, Section 18-200 et 18-274. Consultez la section appropriée et assurer la conformité avec l'une des options proposées.

Lors de la connexion à l'équipement USC depuis un emplacement distant et l'équipement USC est dans une classe dangereuse II, Groupe G environnement, les clients sont invités à suivre les exigences dans CSA 22.2 no. 25. Plus de détails peuvent également être trouvés dans 22,1 CSA 18-252 (Les méthodes de câblage). Il existe diverses options couvertes dans cette section pour le câblage dans une Classe II, Groupe G (poussière) environnement. Sélectionnez la meilleure méthode adaptée pour votre emplacement spécifique.

LPV TREATER SET - UP

The following steps outline the initial set-up of your USC Seed Treating system:

1. Clear the area of bystanders, especially small children, before moving.
2. Be sure there is enough clearance from overhead obstructions and power lines or other equipment to move the machine into its working position.
3. Using a forklift, place the seed treater in the desired position on a level surface.

NOTICE

USC highly recommends that the seed treater be set up inside a building or any covered structure to protect the machine from weathering.

AVIS

USC recommande fortement que le traitement de semences être mis en place à l'intérieur d'un bâtiment ou d'une structure couverte pour protéger la machine des intempéries.

4. Remove any boxes and cords from the drum of the treater.

LPV TREATER SET - UP



The LPV Treater **CAN NOT** be lifted using the forklift pockets and or transported without all four of the shipping brackets re-installed. Failure to do so may cause damage to the tilting frame.



Le LPV Traiteur NE PEUT PAS être soulevée à l'aide des passages de fourches et ou transporté sans les quatre supports de transport ré-installé. Ne pas le faire peut causer des dommages au châssis basculant.

5. Install the drum lift actuator kit (03-17-0111) that is shipped separately using steps “A” through “F” below.

STEP A: Support the discharge end of the treater drum using the lift ring at the top of the discharge assembly.



STEP B: Remove all four of the shipping support brackets. Save for reuse if treater is moved.



LPV TREATER SET - UP

STEP C: Lower the drum slowly until the drum frame is resting on the dead stop pins on both sides of the treater frame.



⚠ WARNING

When removing the actuator (03-17-0104) from the box, ensure that you do not allow the shaft to rotate. The actuator was installed and tested at the factory so the shaft is in the correct position before it was disassembled prior to shipping.

STEP D Insert a clevis pin (06-09-0058) attaching the bottom of the actuator to the bracket on the treater frame cross member.

STEP E: Insert the second clevis pin (06-09-0058) and the two flat washers (06-05-0005) attaching the end of the actuator piston to the bracket on the drum frame. The washers should be on the outside of the frame bracket.



LPV TREATER SET - UP

STEP F: Insert a cotter pin (06-09-0087) in the clevis pins at both ends of the actuator. Then, attach the yellow cable to the motor connector.



NOTICE

After the actuator is installed it should move freely by hand. If something is binding, damage to the actuator or the mounting brackets could occur.

AVIS

Après l'actionneur est installé, il doit se déplacer librement à la main. Si quelque chose est obligatoire, les dommages à l'actionneur ou les supports de montage pourrait se produire.

LPV WEIGH BELT SEED TREATER

WEIGH BELT SET - UP

*Seed Hopper
Assembly .
(Optional)*

*Weigh Belt
Assembly*

*Inlet
Hopper
Hood*

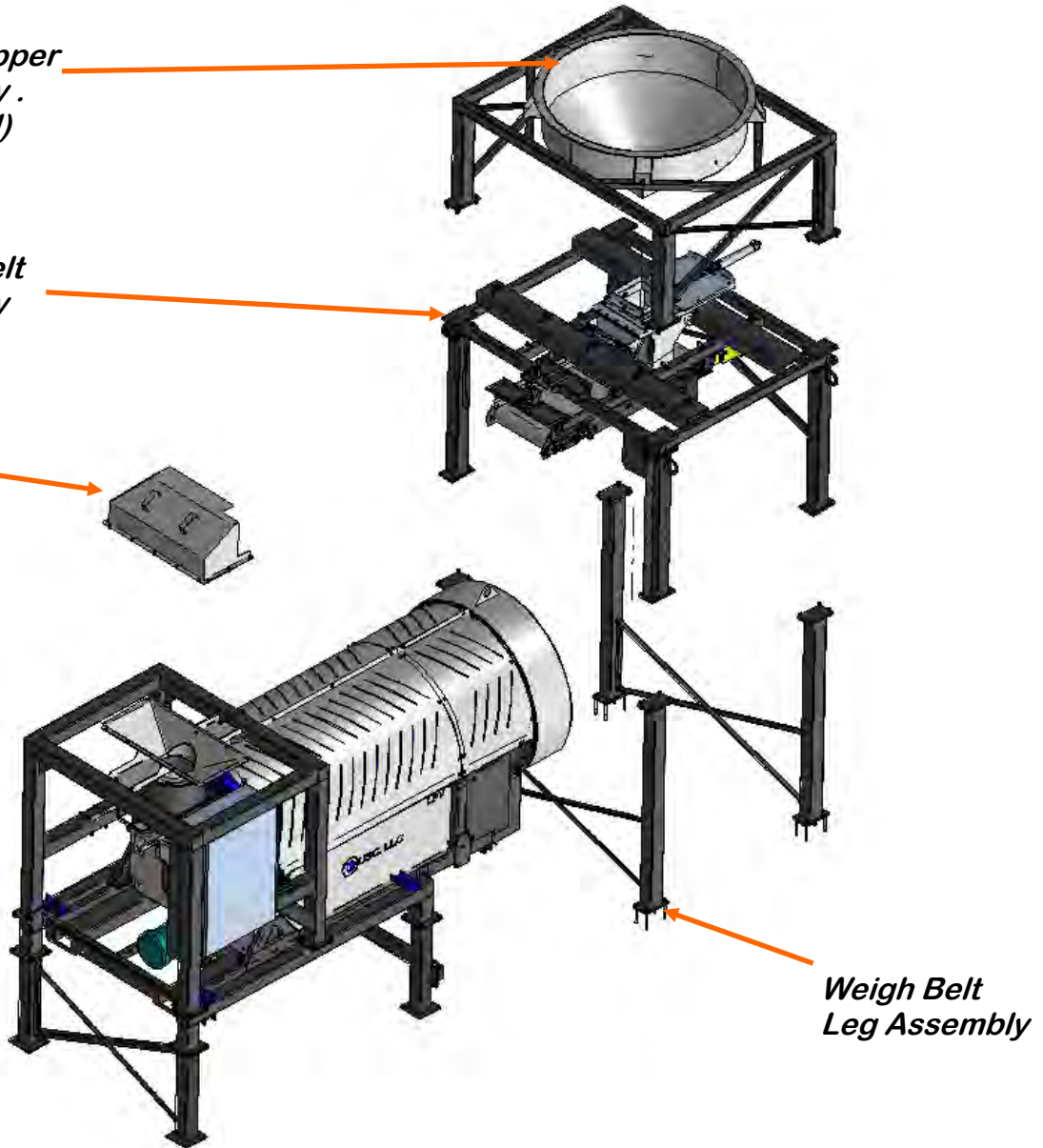

*Weigh Belt
Leg Assembly*

WEIGH BELT SET - UP

1. Remove the inlet hopper hood from the inlet assembly and set it and all of the fasteners aside.
2. Using a forklift, raise the weigh belt assembly so it is centered left to right and the front leg of the weigh belt assembly is 4 5/8" from the middle leg of the treater (below, left). This should place the weigh belt centered along the length of the treater and the end of the front end of the belt at the edge of the inlet (below, right).

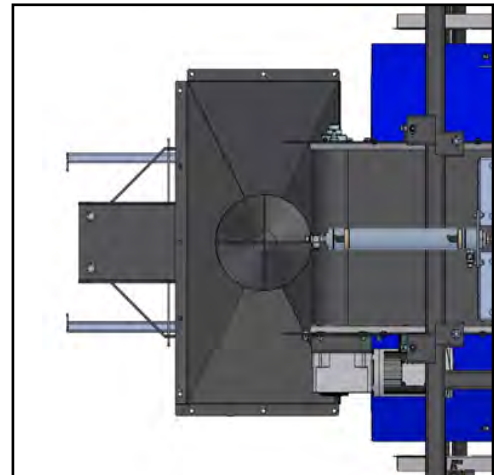
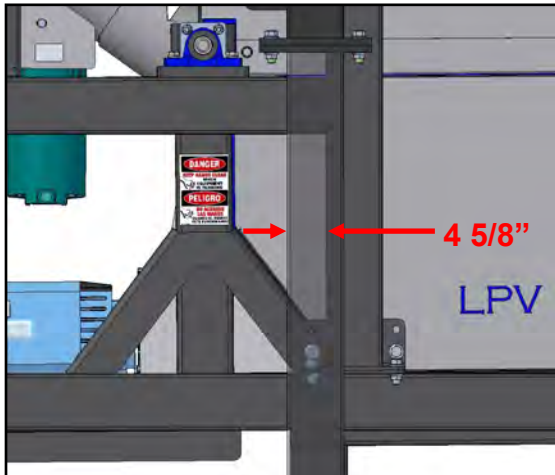

3. Reassemble the inlet hopper hood.
4. Anchor the seed treater and weigh belt in position to prevent the machine from moving during operation.
5. Inspect machine thoroughly for screws, bolts, fittings, etc. which may have come loose during shipping.
6. Store the 2 fifty pound weights for future use in calibration of the load cell.
7. Unpin and cycle the toggle lever (red handle) holding the weigh belt in the transport position.
8. Release the hook on the weigh belt lifting bar. This engages the load cell.
9. Return the toggle lever (red handle) to the vertical position and re-pin

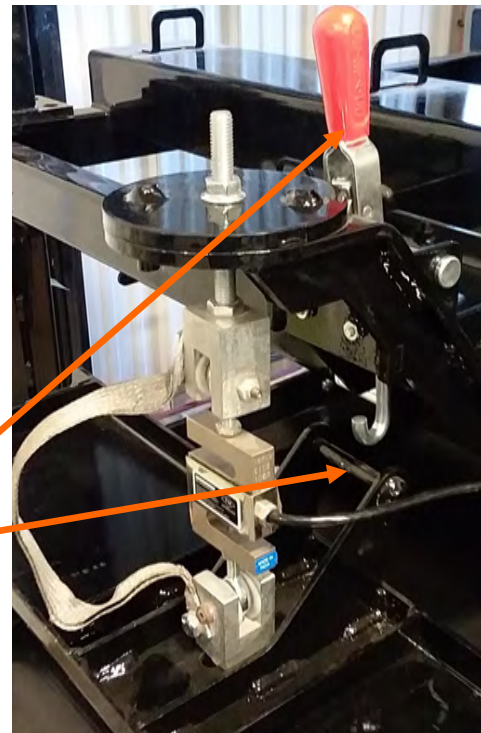

LPV WEIGH BELT TREATER SET - UP

*Static Mixer
Assembly*

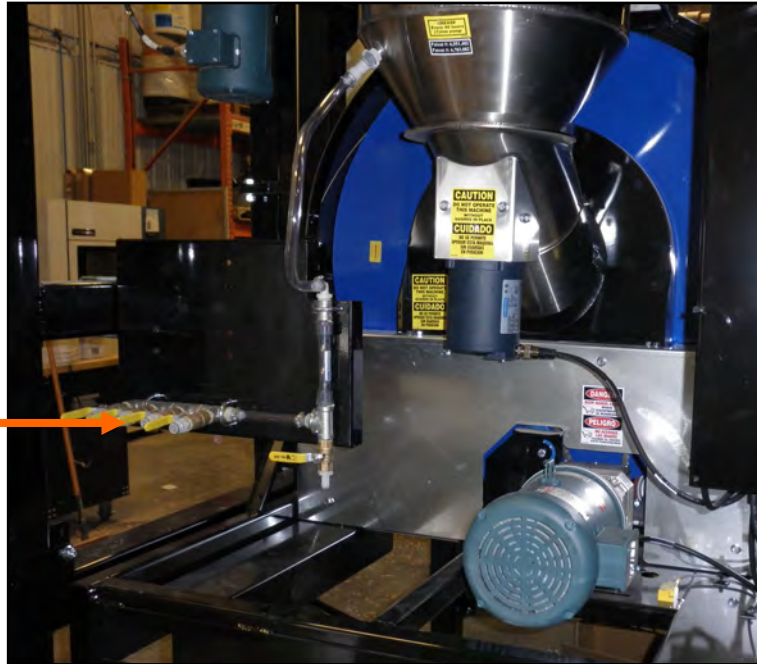

10. The pump stand(s) should be placed on level ground close to the seed treater.
11. Attach the chemical tubing from the pump stand(s) to the static mixer on the seed treater (above). Additional tubing may be added or removed to accommodate your installation.

VERSION 4 LPV TREATER CONNECTIONS
(Except 575v / 3ph)

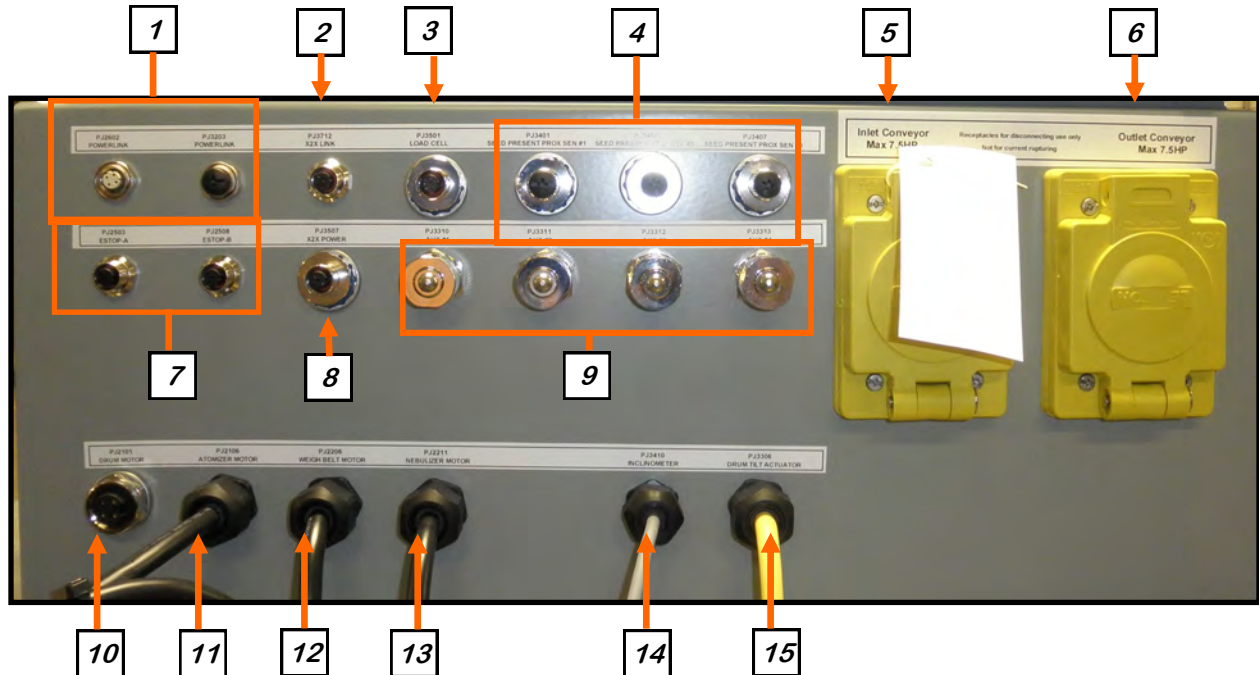

1. Connect a cable with four pin connector to one of the two Powerlink connectors on the MCP. Connect the other end to the Powerlink connector on the closest control panel. Repeat this process until all control panels are connected. It may be MCP to Treater to Tri-Flo® to Bin Site panel. The order or number of devices is not important. It is important that all panel are connected. All pump stand control panels will need to connected in a similar configuration.
2. Connect to the cable at the top of the remote I/O block on the weigh belt to PJ3712.
3. Connect to the load cell on the weigh belt.
4. Not used with the weigh belt.
5. Plug power cable from inlet conveyor here. Max 7.5 HP.
6. Plug power cable from outlet conveyor here. Max 7.5hp.

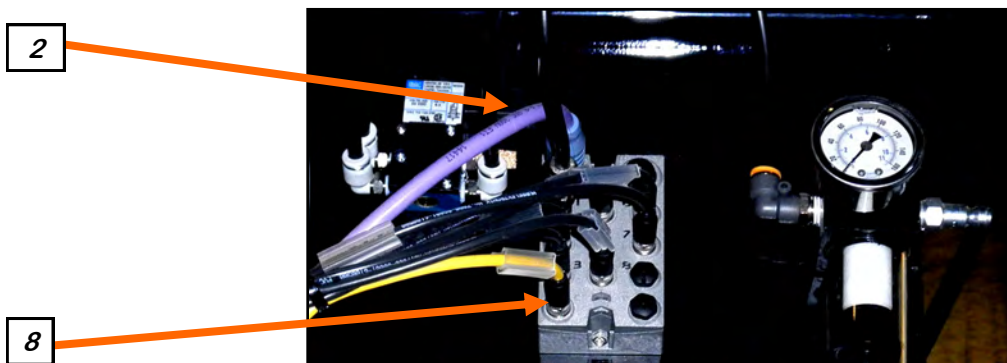

VERSION 4 LPV TREATER CONNECTIONS

DRUM LEVELING SENSOR

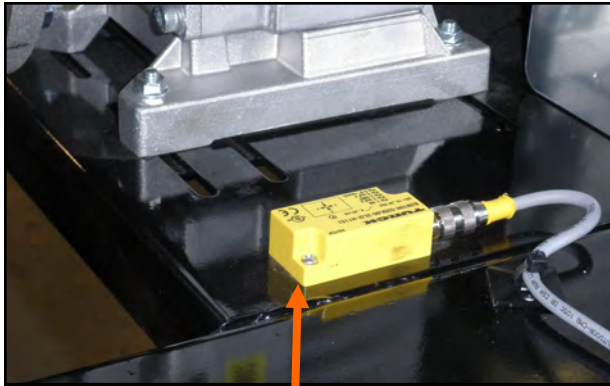

14

DRUM TILT ACTUATOR

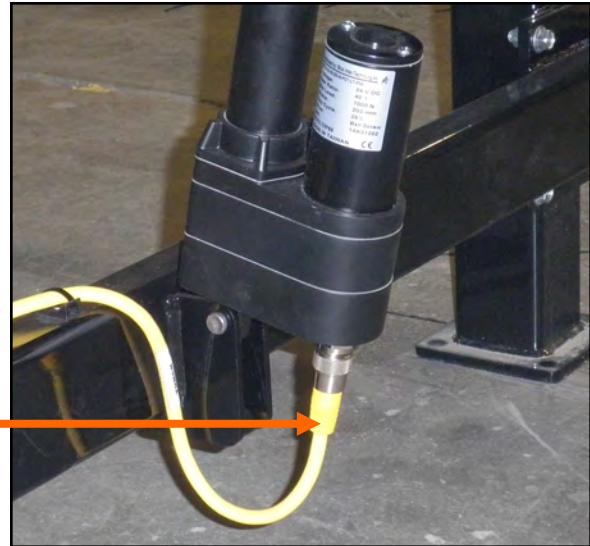



15

7. Connect the red cable to the PJESTOPA on the Main Control Panel (MCP) and then to the PJESTOPB on the next panel that is closest to the MCP. Repeat this process until all control panels are connected in a daisy chain configuration. It may be MCP to Treater to Tri-Flo® to Bin Site panel. The order or number of devices is not important. It is important that each cable is ran from an A connection to a B connection (never A to A or B to B), and that no control panel is left out of the chain. Connect the two red plugs onto each of the remaining open PJESTOP connectors on the first and last panel.
8. Connect to the power cable at the bottom of the Remote I/O Block to PJ3507.
9. If you have manual or semi-automated pump stands connect the 2 pin communication cables from the pump stands to one of the four auxiliary ports.
10. Factory connected to the drum motor.
11. Factory connected to the atomizer motor.
12. Connect cable to weigh belt motor.
13. Factory connected to the nebulizer motor.
14. Factory connected to the inclinometer on next to the drum motor. As shown above.
15. Connect to the drum tilt actuator under the rear of the drum. As shown above.

LPV WEIGH BELT SEED TREATER

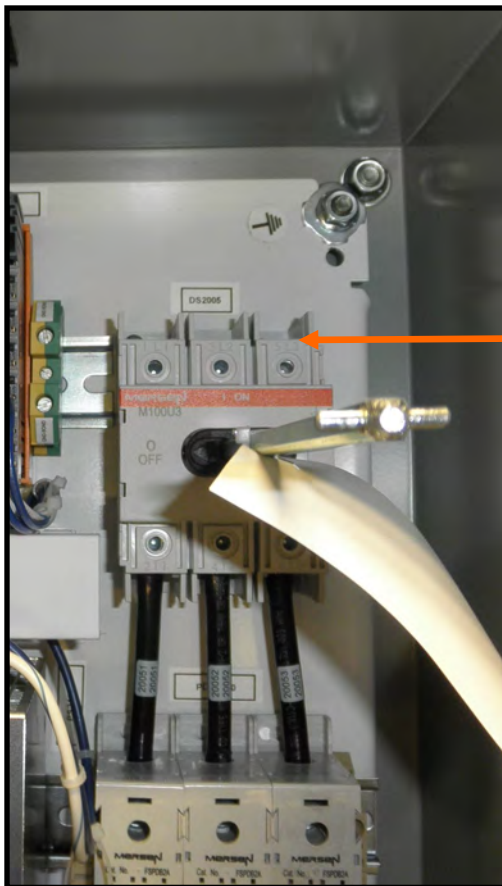
16. Have a certified electrician provide power to the seed treating system. Provide convenient shutdown switches, comply with local electrical codes and ensure that the system is properly grounded and bonded. The USC system must be connected to the same electrical requirements as specified in the main control panel on the power requirement tag, or the electrical schematic shipped with the piece of equipment. This will power the USC LPV seed treater and any attached conveyors.
17. It is required that the air supply have an in-line customer supplied air dryer to protect the air system from contamination. Supply approximately 100 - 110 pounds of air pressure from the dryer to the port on the weight belt controls pad.
18. Reverse the previous steps when removing the machine from its working position.



 Seed Treating Solutions Mfg. By: USC, LLC Max voltage: 115V, 1PH, 60 HZ Schematic number: 03-12-0366A Enclosure rating: UL type 1 Total FLA: 3 Amps Replacement Fuse Chart <table border="1"> <thead> <tr> <th>Fuse</th> <th>Line</th> <th>Size</th> <th>Type</th> </tr> </thead> <tbody> <tr> <td>FU1008</td> <td>1008</td> <td>4A</td> <td>SB TL 150VDC CERAM</td> </tr> <tr> <td>FU1009</td> <td>1009</td> <td>4A</td> <td>SB TL 150VDC CERAM</td> </tr> <tr> <td>FU1209</td> <td>1209</td> <td>3A</td> <td>T SB/TO GARD-3-R</td> </tr> <tr> <td>FU1211</td> <td>1211</td> <td>1A</td> <td>T SB/TO GARD-1-R</td> </tr> </tbody> </table>	Fuse	Line	Size	Type	FU1008	1008	4A	SB TL 150VDC CERAM	FU1009	1009	4A	SB TL 150VDC CERAM	FU1209	1209	3A	T SB/TO GARD-3-R	FU1211	1211	1A	T SB/TO GARD-1-R	 Seed Treating Solutions Mfg. By: USC, LLC Max voltage: 230V, 1PH, 60 HZ Total FLA: 112 Largest Motor FLA: 40 Schematic number: 13-12-0126A Enclosure rating: UL type 1 Short Circuit Current Rating: 5ka RMS Sym, 600V Max WARNING To maintain over current, short-circuit and ground fault protection, the manufacturer's instruction for selection of overload and short circuit protection must be followed to reduce the risk of fire or electrical shock. WARNING If an overload or a fault current interruption occurs, circuits must be checked to determine the cause of the interruption. If a fault condition exists, the current-carrying components should be examined and replaced if damaged, and the integral current sensors must be replaced to reduce the risk of fire or electrical shock. TREATOR CONTROL PANEL See schematic number: 13-12-0126A for interconnections. Replacement Fuse Chart <table border="1"> <thead> <tr> <th>Fuse</th> <th>Line</th> <th>Size</th> <th>Type</th> </tr> </thead> <tbody> <tr> <td>FU2006</td> <td>2006, 2008</td> <td>30A</td> <td>CLASS CC 600V</td> </tr> <tr> <td>FU2010</td> <td>2010, 2012</td> <td>10A</td> <td>CLASS CC 600V</td> </tr> <tr> <td>FU2101</td> <td>2101, 2103</td> <td>10A</td> <td>CLASS CC 600V</td> </tr> </tbody> </table> !! WARNING !! 230Volts/ 1Phase/60 Hertz supply only * Neutral voltage must not exceed 120 Volts!	Fuse	Line	Size	Type	FU2006	2006, 2008	30A	CLASS CC 600V	FU2010	2010, 2012	10A	CLASS CC 600V	FU2101	2101, 2103	10A	CLASS CC 600V
Fuse	Line	Size	Type																																		
FU1008	1008	4A	SB TL 150VDC CERAM																																		
FU1009	1009	4A	SB TL 150VDC CERAM																																		
FU1209	1209	3A	T SB/TO GARD-3-R																																		
FU1211	1211	1A	T SB/TO GARD-1-R																																		
Fuse	Line	Size	Type																																		
FU2006	2006, 2008	30A	CLASS CC 600V																																		
FU2010	2010, 2012	10A	CLASS CC 600V																																		
FU2101	2101, 2103	10A	CLASS CC 600V																																		
 Seed Treating Solutions Mfg. By: USC, LLC Max voltage: 120V, 1PH, 60 HZ Total FLA: 6 Schematic number: 03-12-0484A Enclosure rating: UL type 1 Quality Assurance Approved by: _____ Mfg Date: _____																																					

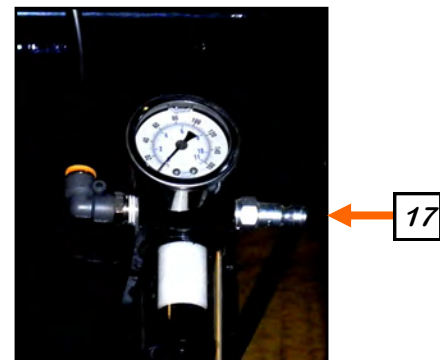

NOTICE

Flexible conduit is recommended for main power supply.

AVIS

Conduit flexible est recommandé pour l'alimentation princi-

SECTION C **MECHANICAL OPERATION**

LPV TREATER WITH WEIGH BELT OVERVIEW

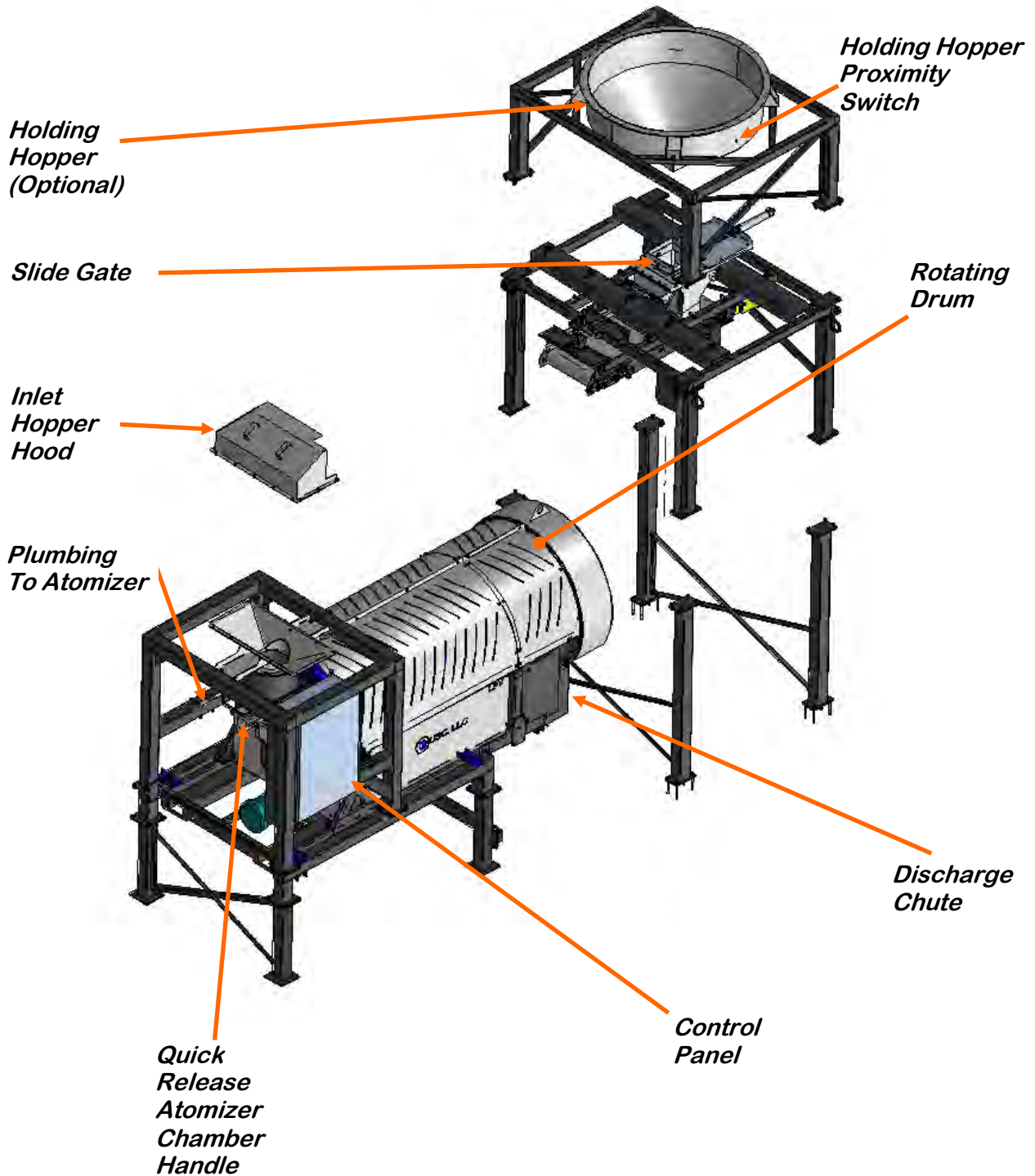

WEIGH BELT

The weigh belt is equipped with four proximity switches. The first switch is located in the holding hopper and controls the inlet conveyor. The second is located above the slide gate. When this switch no longer detects seed it automatically closes the slide gate. The third is located just above the weigh belt. This is active when seed is present on the belt. This and other flow rate variables indicate when seed is exiting from the end of the belt into the inlet hopper. This activates the flow indicator. The flow indicator controls the pump(s) supplying treatment into the atomizer. The fourth is located in the inlet hopper. When this switch detects seed, it stops the weigh belt to prevent seed from overflowing the hopper. The pumps and treater continue to operate for a pre-determined amount of time, then place the entire system in the pause state to prevent the drum from being flooded with untreated seed. The flow rate may then be adjusted and the system may be started again to complete the run. See the Proximity Switch Adjustment Guide in Section F for more information on these switches (see page 44).

The weigh belt is designed to simplify and increase seed flow calibration accuracy. A belt is driven by a variable speed motor, which is set prior to treating the seed. This is hanging by load cells above the atomizer. The weigh belt rotates and dispenses the seed into the atomizer chamber. With the constant turn of the belt, there is a consistent amount of seed always sent through the atomizer.

The weigh belt saves time when switching to different seed sizes and seed types.

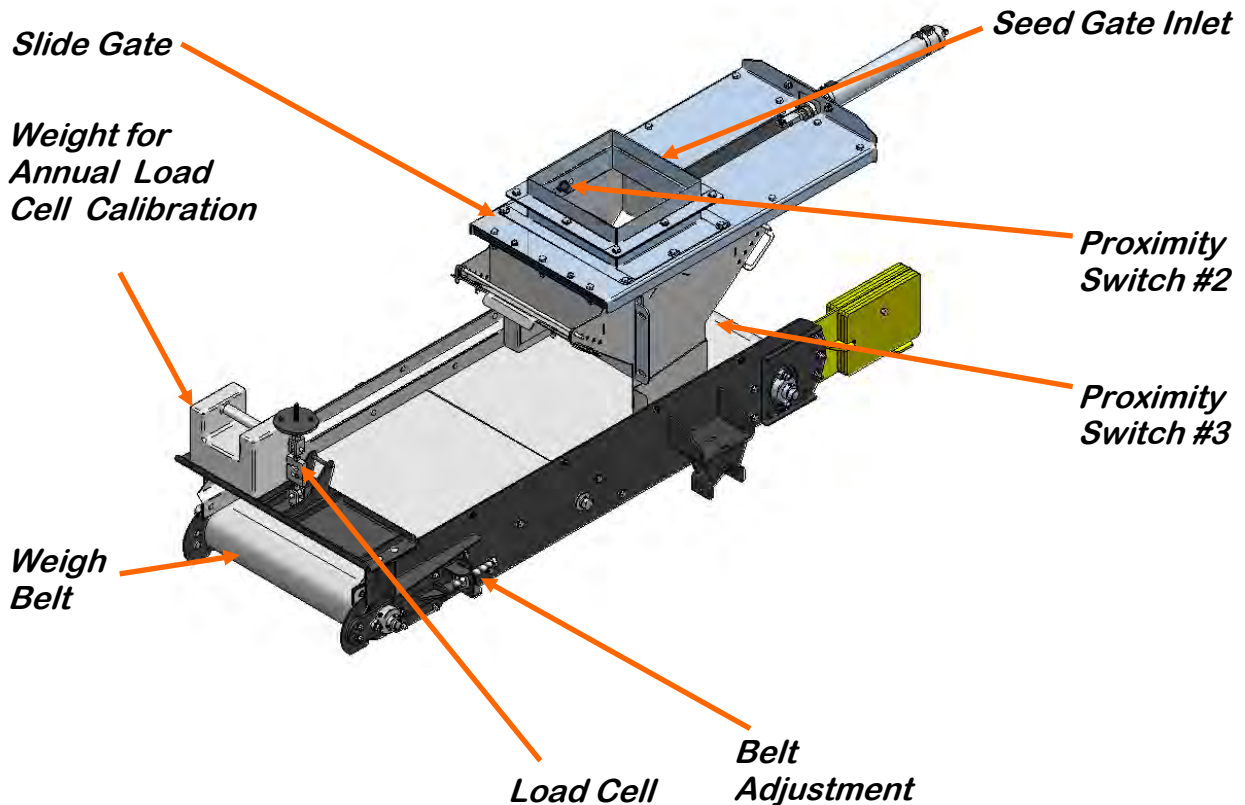

MOVING THE WEIGH BELT

Prior to moving the weigh belt the load cell lock must be engaged.

1. Engage the hook under the lift bar on the weigh belt.
2. The handle returned to the upright and locked position.
3. The pin placed back in place to prevent the handle releasing the belt.
4. The load cell top mount floating above the base plate.

NOTICE

FAILURE TO LOCK THE BELT WILL
DAMAGE THE LOAD CELL.

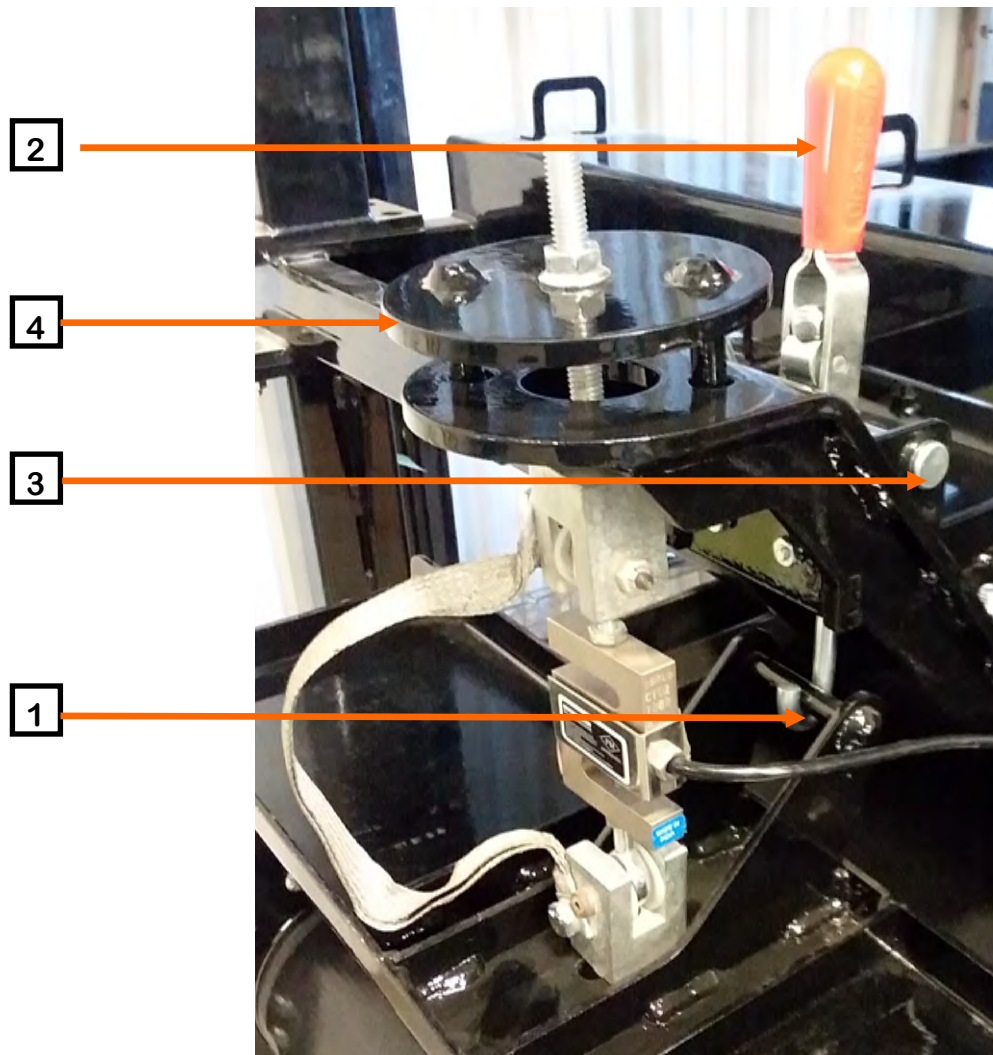

WEIGH BELT ATOMIZER CHAMBER OVERVIEW

The atomizer chamber consists of a patented design which disperses treatment evenly to each seed. A motor drives the atomizer head at approximately 1725 RPM's. As treatment is being pumped into the atomizer chamber, it drops into the atomizer head. The centrifugal force of the spinning head forces the treatment to be sprayed out through a screen covering in all 360 degrees. Meanwhile, seed flows down from the weigh belt and on top of the distribution cone in the seed flow chamber which disperses the seed down around the atomizer head. The weigh belt determines the seed flow rate based on the speed it is running at and how much weight is on it. The atomizer may be easily accessed for cleaning and maintenance by pulling down on the quick release handle and sliding the atomizer away from the treater body (see page 47).

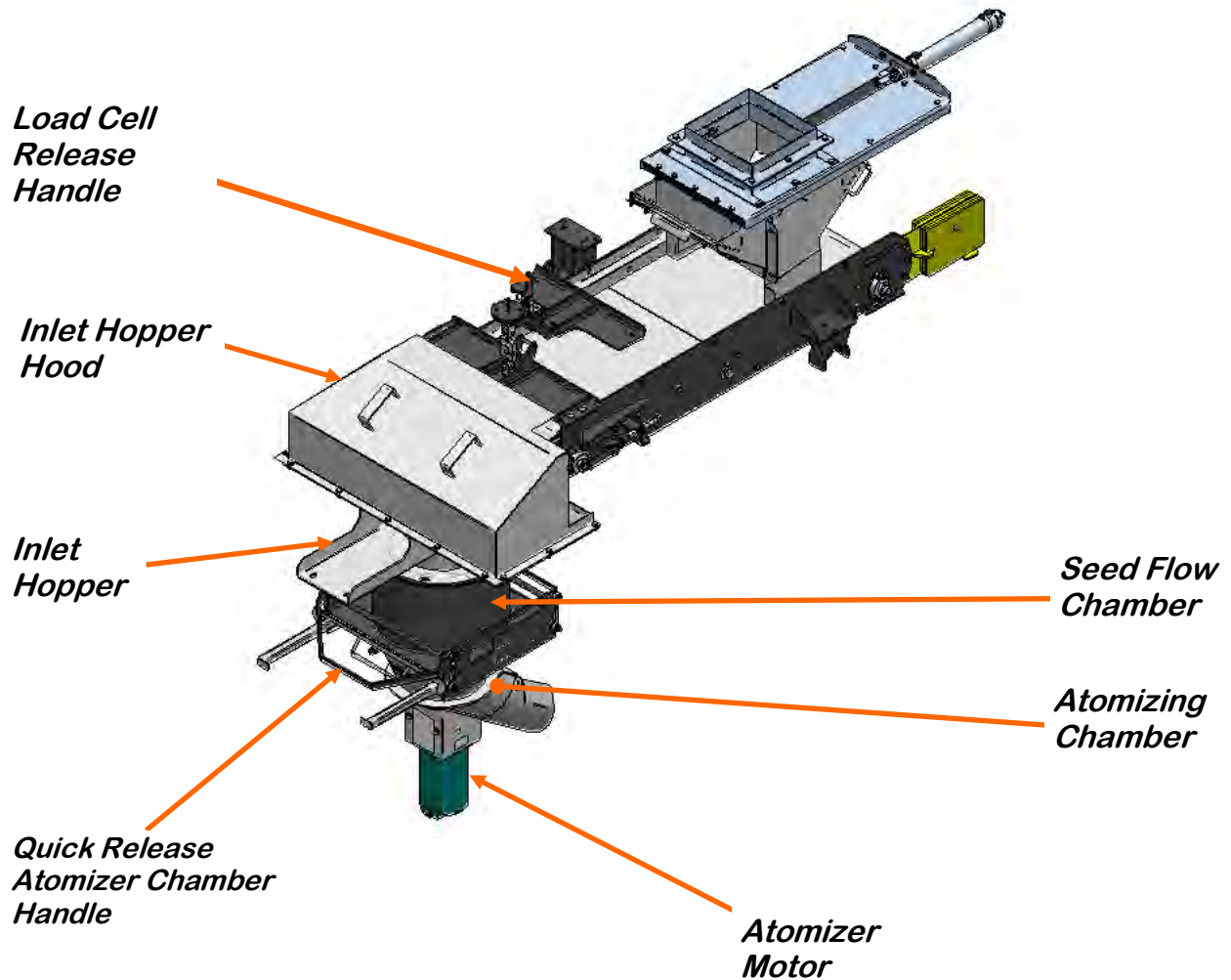

LPV WEIGH BELT SEED TREATER

The Illustration below shows how seed passes through the atomizing chamber. The red represents treatment being dispensed to the seed as it passes through the chamber. After the seed passes through the atomizer, it goes into the drum where the coating process is completed.

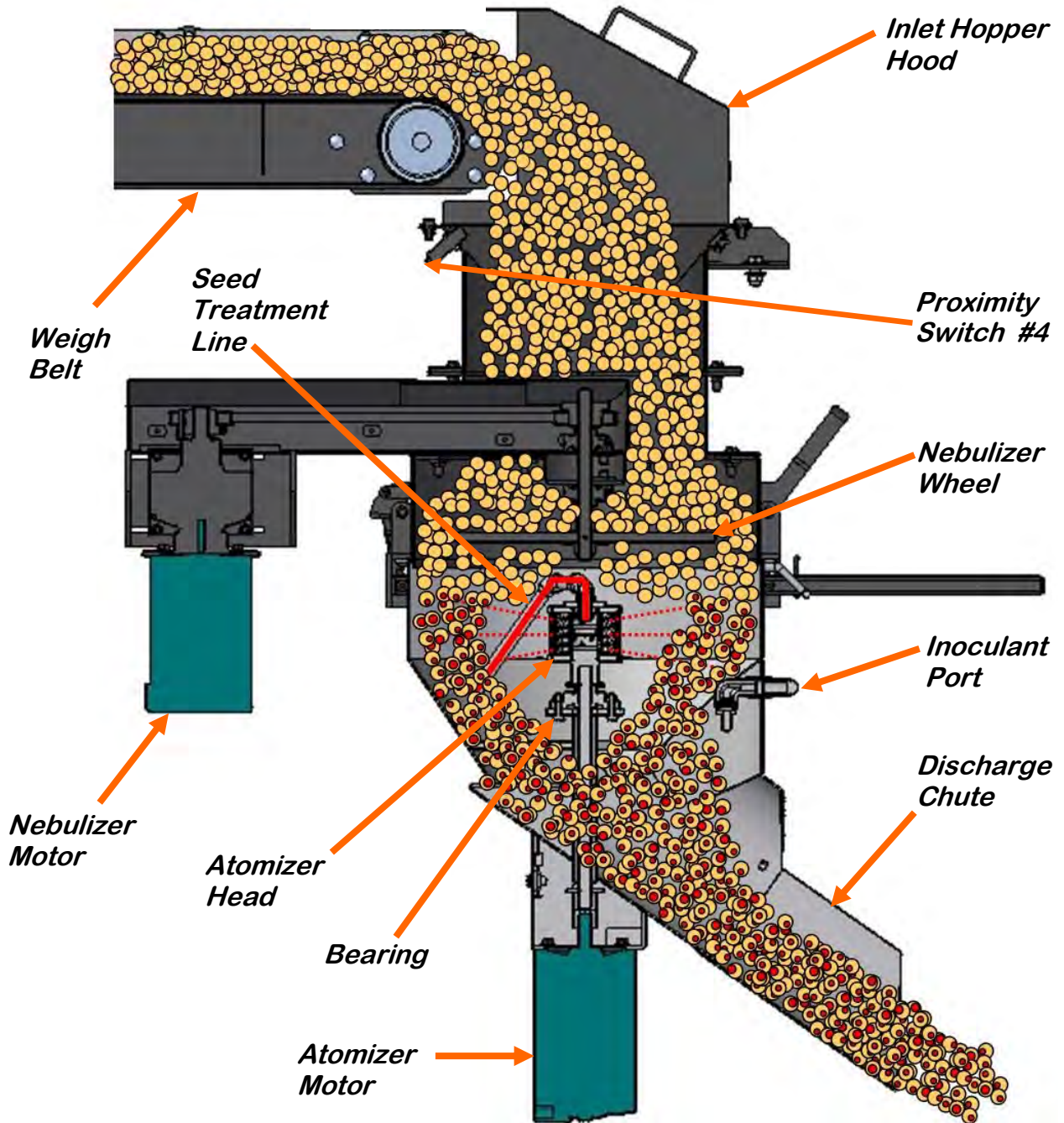

ROTATING DRUM

The rotating drum is 8 feet long and accepts treated seed through the opening on the hopper end. As seed passes through the length of the drum it is tumbled, producing accurate and uniform seed coating. The seed then exits the seed treater out the discharge end of the machine.

! CAUTION

Never allow exposure of persons or clothing to the drive shaft, idler wheels, or the drum during operation. Always have the safety shields in place during operation.

! ATTENTION

Ne jamais laisser l'exposition des personnes ou des vêtements à l'arbre d'entraînement, roues libres, ou le tambour pendant le fonctionnement. Toujours avoir les boucliers de sécurité en place pendant le fonctionnement.

The LPV Treater also comes standard with telescoping fork lift pockets. These pockets may be slid out from underneath the treater to allow a fork lift to pick up the treater from it's discharge end.

! DANGER

The rotating drum is grounded to the equipment structure at the factory, to avoid the possibility of generating static electricity, this bonding mechanism should not be tampered with or removed.

! DANGER

Le tambour rotatif est ancré à la structure de l'équipement en usine, afin d'éviter la possibilité de générer de l'électricité statique, ce mécanisme de liaison ne doit pas être altéré ou enlevé.

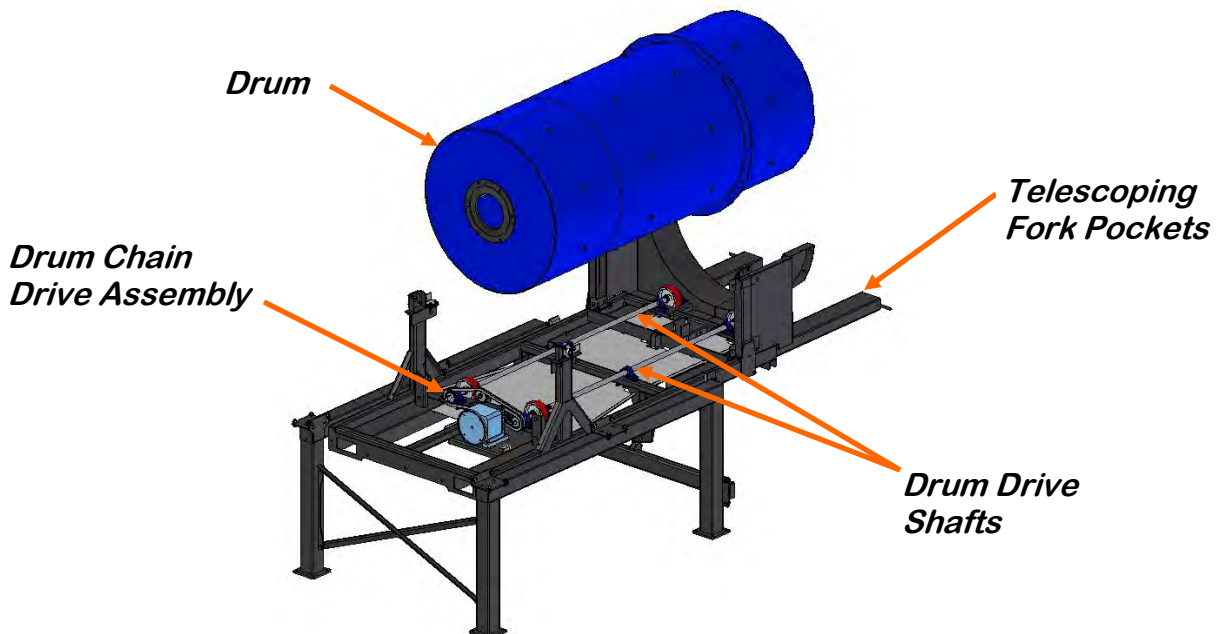

**SECTION
D**

ELECTRICAL OPERATION



HIGH VOLTAGE ~ Always disconnect the power source before working on or near the control panel or lead wires.



HAUTE TENSION ~ Toujours débrancher la source d'alimentation avant de travailler sur ou près du panneau de commande ou les câbles.



HIGH VOLTAGE ~ Use insulated tools when making adjustments while the controls are under power.



HAUTE TENSION ~ Utilisez des outils isolés lors des réglages, tandis que les commandes sont sous tension.

AUTHORIZED PERSONNEL only shall work on the control panel. Never allow anyone who has not read and familiarized themselves with the owner's manual to open or work on the control panels.



Seules personnes autorisées doivent travailler sur le panneau de commande. Ne jamais laisser quelqu'un qui n'a pas lu et se sont familiarisés avec le manuel d'ouvrir ou de travail du propriétaire sur les panneaux de contrôle.

For the LPV Automated Treater HMI instructions, see the appropriate U-Treat Automation manual.

This section provides a general overview and description of the operator control panels for the LPV Seed Treater.



USC recommends the use of a surge protection device with a minimum rating of 400 Joules for all automated main control panels.



USC recommande l'utilisation d'un dispositif de protection contre les surtensions avec une cote minimale de 400 joules pour tous les principaux panneaux de contrôle automatisés.

NOTICE

USC strongly recommends that you implement a routine data export strategy. This will give your company a regularly updated back-up file containing all of the important information in your seed treating system. Customer, seed, bin and chemical profiles, as well as chemical recipes may easily be restored in the event of a catastrophic system failure, such as a lightning strike or PLC failure. Reports may not be imported back into the system, but you will still have an electronic copy for your records. USC recommends daily back-ups.

AVIS

USC vous recommande fortement de mettre en œuvre une stratégie de routine d'exportation de données. Cela donnera à votre entreprise un fichier de sauvegarde régulièrement mise à jour contenant toutes les informations importantes dans votre système de traitement des semences. Clients, semences, bin et chimiques profils, ainsi que des recettes chimiques peuvent être facilement restaurées en cas de défaillance catastrophique du système, comme une grève de la foudre ou l'échec PLC. Rapports ne peuvent pas être importés dans le système, mais vous aurez toujours une copie électronique pour vos dossiers. USC recommande sauvegardes quotidiennes. foudre ou l'échec

LOAD CELL OPERATION AND CALIBRATION

Load cell in the shipping / moving position (Note the hook is engaged with the lifting bar on the weight belt and the top plate of the load cell assembly is floating.)

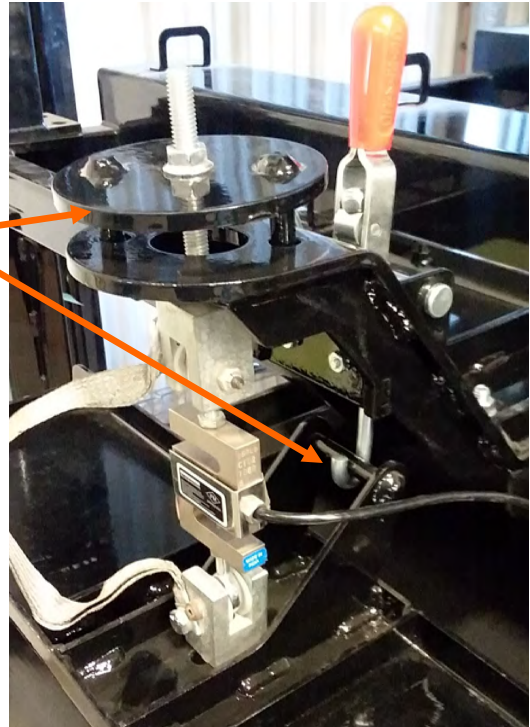

Load cell in the operating position (Note: the hook is not engaged with the lifting bar on the weigh belt and the top plate of the load cell rests firmly on the support plate.)

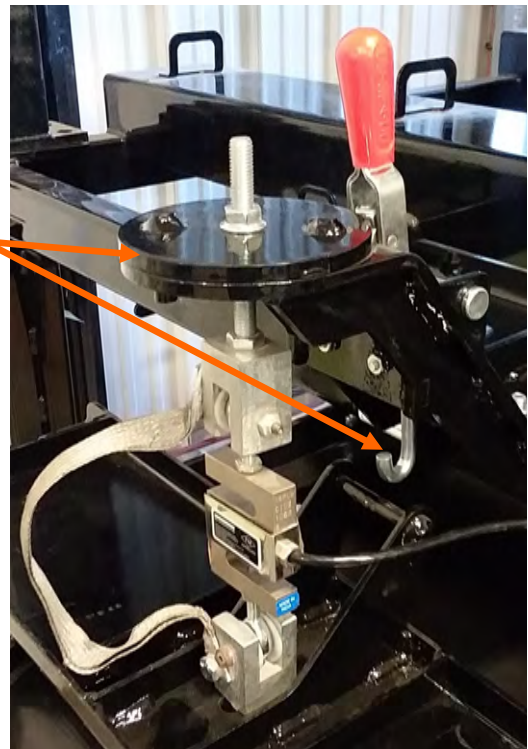

LOAD CELL OPERATION AND CALIBRATION



ELECTROCUTION HAZARD

Extra caution must be exercised when working inside the control panel when it is powered.

DANGEROUS VOLTAGES ARE PRESENT

The load cell calibration needs to be checked periodically (daily, change of seed, after moving the weighing belt). Use the steps below for load cell calibration.

1. Unlock the load cell by removing the pin, cycling the lever down until the hook disengages the belt lift bar, return the lever to the upright position, and replacing the pin.
2. Place the two 50 lb. weights, that came with the machine, on each side of the load cell. These two weights total 100 lbs.
3. Go to the main screen on the control panel. The “BELT WEIGHT” on the main screen, due to internal calculations, will show 200 lbs. (90.7 kg).
4. If the screen shows the correct weight, remove the weights and store. If the screen does not show the correct weight, go to step 5 and re-calibrate the load cell.
5. With the control panel powered, unlock and open the door.
6. With the screw removed to gain access to the calibration switch, apply power to the 201 Weight Transmitter.
7. Press and hold the calibration switch through the opening from the removal of the screw in the prior step for approximately 2 seconds until the display changes to SETUP. This is best done with a small tool.(e.g. a 3/32 or 2mm Hex Key Wrench or small screwdriver.)

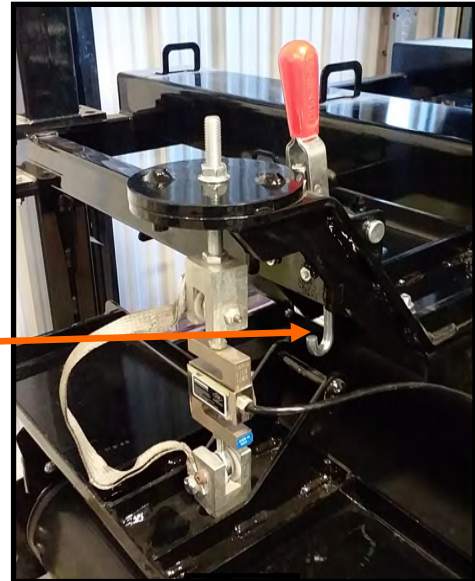

Step 1

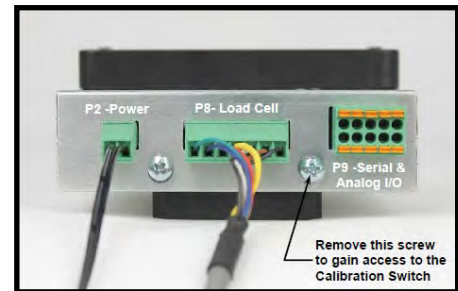

Step 6



Face of unit

LPV WEIGH BELT SEED TREATER

8. Release the calibration switch to begin setup.
9. Press the F2/▲ key to step until the display shows CAL.
10. With CAL = displayed, press the F3/← key. The display will change to CAL=. Proceed to the CAL= (Perform Calibration) parameter.
11. With CAL= displayed, press the F3/← key. The display will change to no.
12. Press the F2/▲ key to toggle to YES and then press the F3/← key. The display will change to CAL 1=. Proceed to the CAL 1= parameter.
13. The display will show CAL 1 =. This is the first of two calibration weights. This weight is ZERO (NO LOAD).
14. Press the F3/← key to view the current setting.
15. Press the F3/← key again to set absolute zero.
16. Starting at the left and proceeding right, a series of dashes will appear and then disappear. Then the display will show CAL 2=.
17. This is the second of two calibration weights. This weight is with the two 50lb. test weights.
18. Press the F3/← key to view the current setting.
19. Use the F1/◀ and F2/▲ to input the value of the test weights. The display must read 100.000.
20. Place two 50lb. Weights on the scale platform, wait for the weigh belt to stop moving, then press the F3/← key.
21. Starting at the left and proceeding right, a series of dashes will appear and then disappear. Then the display will show F SPAn.
22. The calibration process is now complete. Press F1/◀ until you are returned to the starting screen.
23. Replace the screw removed in step 7.
24. Close and lock the control panel.
25. Remove and store the weights .

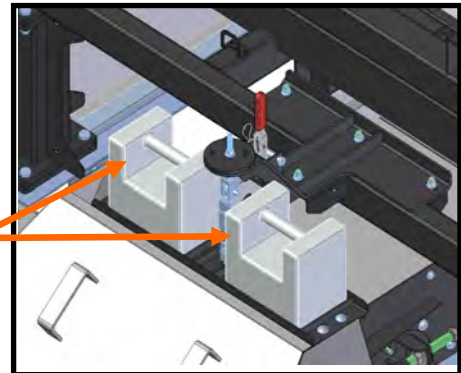

TROUBLESHOOTING SECTION E

Below is a table describing the most frequent mechanical problems and solutions with the USC LPV Seed Treater. For further assistance, contact your authorized dealer

Problem	Possible Cause	Solution
Inlet Conveyor will not turn on.	<ol style="list-style-type: none"> 1. Inlet conveyor proximity switch is activated. 2. Inlet conveyor proximity switch is too sensitive. 3. Overload is tripped. 4. Conveyor is plugged into wrong outlet on seed treater panel. 	<ol style="list-style-type: none"> 1. Clean proximity switch 2. Adjust the inlet conveyor proximity switch sensitivity by turning the adjustment screw counter-clockwise (page 44). 3. Reset inlet conveyor overload. 4. Check to make sure the inlet conveyor is plugged into the inlet conveyor receptacle.
Inlet conveyor will not shut off when hopper is full.	<ol style="list-style-type: none"> 1. Seed is not hitting proximity switch. 2. Proximity switch is not set sensitive enough. 3. Inlet conveyor is plugged into wrong receptacle. 4. Hopper proximity switch is not connected 	<ol style="list-style-type: none"> 1. Make sure seed is hitting proximity switch. 2. Adjust the inlet conveyor proximity switch by turning the adjustment screw clockwise (page 44). 3. Make sure inlet conveyor is plugged inlet conveyor receptacle. 4. Connect hopper proximity switch.
Pump will not turn on in AUTO	<ol style="list-style-type: none"> 1. Proximity switch is not staying covered. 2. Atomizer is not on. 3. Proximity switch is not sensitive enough. 4. Pump stand two-wire cord is not plugged into to treater main panel. 5. Both the Chemical Pump switch on the Pump Stand and the Pump/Aux Control on the HMI screen need to be set to AUTO. 	<ol style="list-style-type: none"> 1. Make sure proximity switch is staying covered with seed 2. Turn on atomizer. Atomizer must be on to run the pump in Auto. 3. Adjust pump proximity switch sensitivity by turning the adjustment screw clockwise (page 44). 4. Plug the pump stand two-wire cord into the main treater panel. 5. Set both the Pump Stand switch and Pump/Aux on the HOA screen to AUTO.
Pump is fluctuating.	<ol style="list-style-type: none"> 1. Restriction in tubing 2. Filter is plugged or missing gasket. 	<ol style="list-style-type: none"> 1. Flush tubing and check filter for any restrictions. 2. Clean filter and check for gasket.

LPV WEIGH BELT SEED TREATER

Problem	Possible Cause	Solution
Pump will not turn off in AUTO when seed runs out.	<ol style="list-style-type: none"> 1. Proximity switch is dirty. 2. Proximity switch is set too sensitive. 	<ol style="list-style-type: none"> 1. Clean proximity switch. 2. Adjust the pump proximity switch sensitivity by turning adjustment screw counter-clockwise (page 44).
Seed calibration is fluctuating.	<ol style="list-style-type: none"> 1. Seed treater supply hopper is not staying full. 2. Restriction in the supply hopper or weigh belt. 3. Build-up in the atomizing chamber. 	<ol style="list-style-type: none"> 1. Make sure the supply hopper and weigh belt are staying full. May have to lower seed flow rate in order to have a consistent flow of seed. 2. Check supply hopper and seed wheel for any debris, and remove. 3. Remove atomizing housing and clean out any build-up of material.
Drum is slipping and seed is coming out the inlet side of the drum.	<ol style="list-style-type: none"> 1. Drum is wet. 2. The seed treater is set too level. 3. Chains are too loose. 	<ol style="list-style-type: none"> 1. Dry off any moisture that may have collected on the outside of the drum. 2. Adjust the slope of the seed treater to at least a 3" drop from front to back. If desired, more slope can be applied. 3. Check and tighten the drive chains. Also check the chain alignment.
None of the motors will turn to ON in HAND mode.	<ol style="list-style-type: none"> 1. Processor is faulted. 2. Emergency Stop button is activated. 3. The Emergency Stop RESET button has not been pressed after the Emergency Stop button has been pulled out. 	<ol style="list-style-type: none"> 1. Disconnect power and wait 30 seconds before reconnecting power. 2. Pull out the Emergency Stop button. 3. After the Emergency Stop button has been pulled out, press the Emergency Stop RESET button.
E-stop is flashing.	<ol style="list-style-type: none"> 1. An E-stop may be depressed. 2. Power may not be on to the control panels. 3. One of the control panels may not be connected to all of the others. 	<ol style="list-style-type: none"> 1. Ensure all E-stops are not depressed. 2. Check incoming power to each control panel. 3. Check the wiring and connections to each control panel.

MAINTENANCE SECTION F

Proper maintenance of the LPV Weigh Belt Seed Treater is critical for peak performance, reliability and accuracy of this system. The following is a guideline for the type of maintenance and servicing that should be performed on this unit. Your environment and uses may require additional maintenance and service beyond this list to assure a reliable and safe unit. The operator of this unit has ultimate responsibility to identify areas of concern and rectify them before they become a hazard or safety issue. There is no substitute for a trained, alert operator.



DANGER Do not put this unit into operation with any questionably maintained parts. Poor performance or a hazard may occur.



! DANGER Ne mettez pas cet appareil en service avec une pièce inutilisable. Une mauvaise performance ou un danger peut survenir.



DANGER Do not use compressed air or water under pressure to clean any of the components of the USC equipment.



! DANGER Ne pas utiliser d'air comprimé ou de l'eau sous pression pour nettoyer l'un des composants de l'équipement USC.



WARNING Failure to maintain the proper belt tension will cause the belt to slip. This will damage the belt and head drive pulley. If the belt is not tracking correctly, it can ride along one edge causing the belt to fray on the sides. Either problem will cause the belt to burn or wear out prematurely.



! AVERTISSEMENT Défaut de maintenir la tension de la courroie provoquera la courroie de glisser. Cela pourrait endommager la courroie et la tête d'entraînement pulley. Si la courroie ne suit pas correctement, il peut rouler le long d'un bord causant la courroie effilocheur sur les côtés. Soit problème provoquera la ceinture de brûler ou d'usure prématurée.

PROXIMITY SWITCH ADJUSTMENT GUIDE

If a proximity switch is not working properly, this can be caused by wear, dust, or even moisture. The first step is to clean the lens of the proximity switch. If this does not solve the problem, the next step would be to adjust the sensitivity of the proximity switch.

The LED lights indicates the power status. If they are active the device is powered.

The center LED is when the switch closes.

Using the small screwdriver, you can adjust the proximity switch by turning the sensitivity dial of the proximity switch.

- Turn Clockwise to make the proximity switch more sensitive.
- Turn Counterclockwise to make the proximity switch less sensitive.



GREASING

Use an SAE multipurpose high temperature grease with extreme pressure (EP) performance. Also acceptable is an SAE multipurpose lithium-based grease.

- Use a Maintenance Checklist to keep record of all scheduled maintenance.
- Use a hand-held grease gun for all greasing.
- Wipe grease fitting with a clean cloth before greasing to avoid injecting dirt and grit.
- Replace and repair broken fittings immediately.

NOTICE

If fittings will not take grease, remove and clean thoroughly. Also clean lubricant passageway. Replace fitting if necessary.

AVIS

Si les raccords ne prendront pas la graisse, enlever et nettoyer. Aussi propre passage de lubrifiant. Remplacer approprié si nécessaire .

WEIGH BELT SERVICING INTERVALS

Every 40 hours or Weekly

1. Check the conveyor belt tension and alignment.
2. Grease conveyor bearings.
 - A. Two bolt flanged bearings, tail roller bearings right and left (2 locations).
 - B. Two bolt flanged bearings, drive roller bearings right and left (2 locations).
3. Wipe down the motor casing with a damp cloth making sure to remove all dust that may have collected since the last maintenance date. Record the cleaning on the company required documents. If operating in a CSA 22.1, Class II, Division 2, Group G hazardous area, USC recommends this step be performed on a daily basis.
 - Essuyez le carter moteur avec un chiffon humide en veillant à éliminer toutes les poussières qui peuvent avoir perçu depuis la dernière date de maintenance. Enregistrez le nettoyage sur la société les documents requis. Si opérant dans un CSA 22.1, Classe II, Division 2, Groupe G zone dangereuse, USC recommande cette étape être effectuée sur une base quotidienne.

WEIGH BELT TENSION AND ALIGNMENT - TAIL END

To maintain the belt, follow this procedure:

NOTICE Place all controls in neutral or off, stop motor and disable power source following Lockout Tagout procedures before working on belt.

AVIS Placez toutes les commandes au point mort ou hors tension, arrêter le moteur et désactiver la source d'alimentation en suivant les procédures de verrouillage Tagout avant de travailler sur la ceinture.

1. If the belt needs to be tightened to prevent slippage, use the take-up adjustments on the tail end..
2. The belt is tightened by turning both take-up adjustments an **equal** number of turns.
3. Check the alignment. The belt should be centered.
4. Turn the belt 1/2 revolution when the belt is new and check the tail roller. If out of alignment, the belt will move to the loose side. Loosen the jam nut and use the bearing position bolts to set the position. Tighten jam nut.
5. Run and check again. Check frequently during the first few minutes of operation and then several times during the first 10 hours. The belt normally seats itself during the first 10 hours of operation and can be checked weekly after that.
6. The belt is properly aligned when the belt runs in the center of the head and tail

Loosen these jam nuts before adjusting the bearing position bolt

Use this bolt to tighten and align the belt

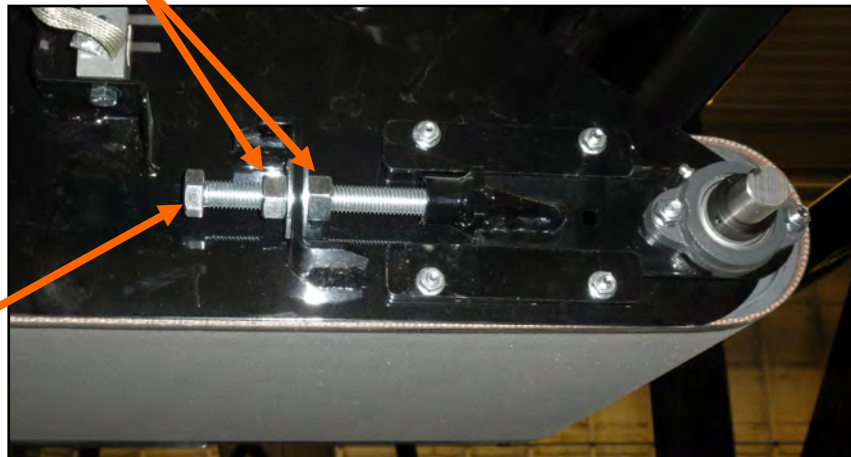

ATOMIZER

To access the inside of the atomizer housing, disconnect the motor power cable from the atomizer motor, push up on the quick release handle and slide out the atomizer. After completing maintenance, slide the atomizer back into the operating position, pull down quick release handle to lock it in place and reconnect the motor power cord.

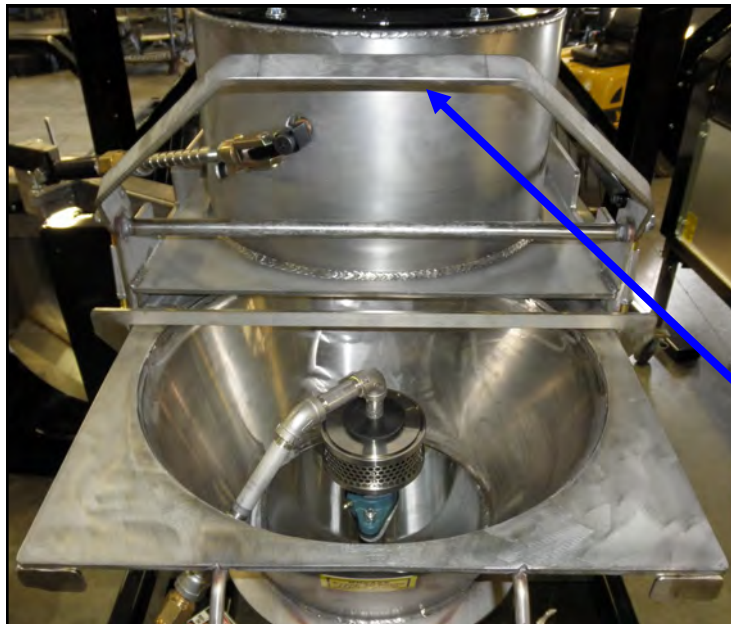

Quick-Release Handle

Atomizer Head

1. Slide out atomizer housing and grease bearing inside. Bearing needs just one pump of grease every 40 hours of operation (right).
2. Clean any build up inside the housing and the atomizer head. To remove the atomizer head, loosen the set screw located on the bottom of the head.
3. Check for any play in the atomizer shaft.
4. Make sure the atomizer spins smoothly.
5. Ensure the adjustable chute is fitting completely into the drum opening. Adjust if necessary.

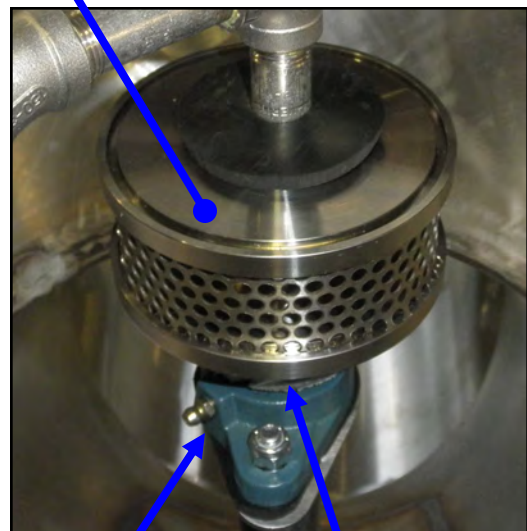

Bearing

Set Screw

ATOMIZER MOTOR

- Wipe down the motor casing with a damp cloth making sure to remove all dust that may have collected since the last maintenance date. Record the cleaning on the company required documents. If operating in a CSA 22.1, Class II, Division 2, Group G hazardous area, USC recommends this step be performed on a daily basis.
- Essuyez le carter moteur avec un chiffon humide en veillant à éliminer toutes les poussières qui peuvent avoir perçu depuis la dernière date de maintenance. Enregistrez le nettoyage sur la société les documents requis. Si opérant dans un CSA 22.1, Classe II, Division 2, Groupe G zone dangereuse, USC recommande cette étape être effectuée sur une base quotidienne.

DRIVE AND DRUM

- Remove drum guards and inspect all welds and structural components on the frame and drum for bends, cracks and damage.
- Inspect pillow block bearings and grease every 40 hours of operation.
- Inspect drive wheels for unordinary wear and set screws for tightness.
- Inspect the Neoprene idler wheels for unordinary wear and adjust if necessary.
- Remove drive guards, tighten and lubricate chain every 40 hours of operation.
- Wipe down the motor casing with a damp cloth making sure to remove all dust that may have collected since the last maintenance date. Record the cleaning on the company required documents. If operating in a CSA 22.1, Class II, Division 2, Group G hazardous area, USC recommends this step be performed on a daily basis.
- Essuyez le carter moteur avec un chiffon humide en veillant à éliminer toutes les poussières qui peuvent avoir perçu depuis la dernière date de maintenance. Enregistrez le nettoyage sur la société les documents requis. Si opérant dans un CSA 22.1, Classe II, Division 2, Groupe G zone dangereuse, USC recommande cette étape être effectuée sur une base quotidienne.

NEBULIZER SYNCHRONOUS BELTS

High torque, Standard and Metric synchronous belts should be installed to fit pulleys snugly, neither too tight nor too loose. The belts positive grip eliminates the need for high initial tension. When a belt is installed with a snug but not overly tight fit, longer belt life, less bearing wear and more quiet operation will result. Overtight belts may cause early failure and should be avoided. With high torque a loose belt may jump teeth upon startup. If this occurs, the tension should be increased gradually until satisfactory operation is achieved.

To properly tension a synchronous belt, place belt on pulleys and adjust take up until the belt teeth mesh securely with the pulley grooves. Measure belt span T, Then tighten belt so it deflects 1/64-inch for every inch of belt span when a force as specified in the table below is applied to the top of the belt. For belts wider than two inches, a metal or wooden strip 3/4 to 1 inch wide should be placed across the belt between it and the tester to prevent distortion.

The following range of deflection forces are normally adequate for drive installation. Actual installation tension required depends on peak loads, system rigidity, number of teeth in mesh, etc.

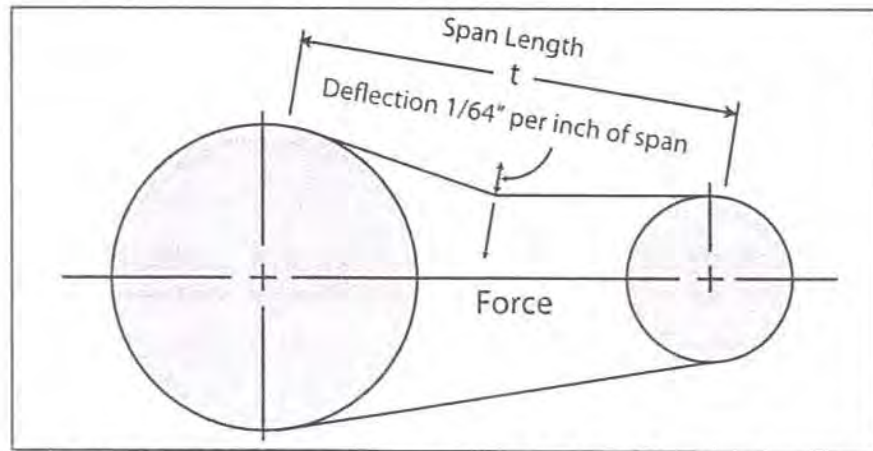

MEASURE THE SPAN LENGTH "T" AS SHOWN IN THE SKETCH ABOVE.

BELT PITCH	BELT WIDTH	DEFLECTION FORCE
L (3/8 Inch)	1/2 Inch	7 Oz
	3/4 Inch	11 Oz
	1 Inch	1 Lb
H (1/2 Inch)	3/4 Inch	2 Lbs
	1 Inch	2-1/2 Lbs
	1-1/2 Inch	4 Lbs

ELECTRICAL PANEL

- Check and tighten wire connections.
- Check quick connects on bottom of control panel.
- Check to see if starters and/or overloads are tripped.
- Check to see if relays, timers and/or breakers are tripped.
- Check and set the proximity switches. (page 44).
- Check quick connects on end of Auxiliary cord.
- Check relay and fuse holder.
- Check power cords for cuts or frays and ensure ground is present.

STORAGE SECTION G

When storing the LPV Weigh Belt Seed Treater for long periods of time, the following procedure must be followed to reduce the chance of rust, corrosion and fatigue of the treater. You can also use these steps when storing the machine for the winter.



A dust mask and protective rubber gloves shall be used when cleaning the machine.

WEIGH BELT

1. Turn power off to the treater and treater components.
2. Place the load cell in the transport position with the hook engaging the lift bar on the weigh belt and pinned.
3. Inspect all welds and structural components for bends, cracks and damage.
4. Remove the inlet hopper cover and bottom seed gate cover that has the seed on belt proximity switch mounted to it. Inspect belt, pulleys and proximity switch.
5. Use a vacuum to clean out any seeds and excess build-up that may have occurred during operation.
6. Turn power back on to the treater and run weigh belt to help remove any additional debris.
7. Use a vacuum to clean out any seeds and excess build-up that may have occurred during operation.
8. Wipe down the motor casing with a damp cloth making sure to remove all dust that may have collected since the last maintenance date.
9. Wipe off and clean the lens of the proximity switches.
10. Disconnect power and mount all guards back in place.
11. Tarp or cover the supply hopper and weigh belt to keep out any dirt or unwanted pests.

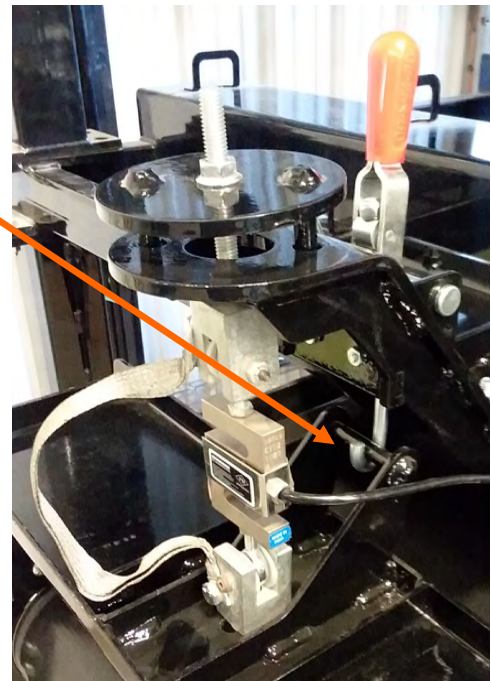

ATOMIZER CHAMBER

1. Remove and clean the atomizer housing.
2. Remove the atomizer head and stainless steel plumbing. The atomizer head may be disassembled (right), for easier cleaning. It is threaded together and can simply be unscrewed.
3. Reinstall the atomizer head and plumbing. Grease the bearing and spin the atomizer head a few times to ensure all grease has been worked into the bearings.



ROTATING DRUM

1. Remove the shields and clean out any seed that may have fallen underneath the drum.
2. Clean out any residue left on the inside of the drum and around the seed lifters.
3. Lubricate the chain to keep from corroding in storage.

FINAL

1. Disconnect power to the machine.
2. Store the machine inside a protective building to keep it from being exposed to the weather.
3. Ensure all guards and safety labels are in place.

LPV WEIGH BELT SEED TREATER

NOTES:

SECTION
H**USC LIMITED WARRANTY**

Rev II 01AUG20

USC, LLC, (Manufacturer) warrants its seed treating equipment as follows:

1. Limited Warranty: Manufacturer warrants that the Products sold hereunder will be free from defects in material and workmanship for a period of 18 months from date of shipment. Manufacturer further provides a 12 month warranty on specific equipment supplied with a warranty card. The 12 month warranty begins upon USC receipt of warranty card from Wholesaler and must be submitted to USC within 18 months of stock equipment purchase by wholesaler to be valid. If the Products do not conform to this Limited Warranty during the warranty period, consumer shall notify Manufacturer in writing (on the approved USC warranty claim form) of the claimed defects and demonstrate to Manufacturer satisfaction that said defects are covered by this Limited Warranty (through pictures, video or other objective data). If the defects are properly reported to Manufacturer within the warranty period, and the defects are of such type and nature as to be covered by this warranty, Manufacturer shall, at its expense, furnish replacement Products or, at Manufacturer's option, replacement parts for the defective products. Shipping and installation of the replacement Products or replacement parts shall be at the Consumer's expense. All replacement parts orders through USC will carry their specific manufacturer's standard warranty including serialized parts manufactured by USC. USC will not warrant parts outside of the standard USC warranty period. USC will not extend any warranty due to replaced parts. The end user is responsible for all shipping and handling expenses for parts returned to USC under this section which may or may not be included in that specific warranty. USC will pay shipping expense between USC's vendor and USC.

2. Other Limits: THE FOREGOING IS IN LIEU OF ALL OTHER WARRANTIES, EXPRESSED OR IMPLIED, INCLUDING BUT NOT LIMITED TO THE IMPLIED WARRANTIES OF MERCHANTABILITY AND FITNESS FOR A PARTICULAR PURPOSE. Manufacturer does not warrant against damages or defects arising from improper installation (where installation is by persons other than Manufacturer), against defects in products or components not manufactured by Manufacturer, or against damages resulting from such non-Manufacturer made products or components. Manufacturer passes on to the consumer the warranty it received (if any) from the maker of such non-Manufacturer made products or components. This warranty also does not apply to Products upon which repairs and / or modifications have been affected or attempted by persons other than pursuant to written authorization by Manufacturer. This includes any welding on equipment which could damage electrical components. Manufacturer does not warrant against casualties or damages resulting from misuse and / or abuse of Products, improper storage or handling, acts of nature, effects of weather, including effects of weather due to outside storage, accidents, or damages incurred during transportation by common carrier or Dealer/customer arranged freight. Any replacement or repair covered under this warranty will **not** extend the warranty period. The remainder of the manufacturer's warranty will remain in force until stated expiration from point of sale.

3. Exclusive Obligation: THIS WARRANTY IS EXCLUSIVE. The sole and exclusive obligation of Manufacturer shall be to repair or replace the defective Products in the manner and for the period provided above. Manufacturer shall not have any other obligation with respect to the Products or any part thereof, whether based on contract, tort, strict liability or otherwise. Under **no** circumstances, whether based on this Limited Warranty or otherwise, shall Manufacturer be liable for lost profits, lost revenue, lost sales (whether direct or indirect damages), incidental, special, punitive, indirect or consequential damages. Consumer shall make no claims for renumeration for any loss as a result of USC equipment and USC shall reject any and all claims that may arise as stated herein.

4. Other Statements: Manufacturer's employees or representatives' oral or other written statements do not constitute warranties, shall not be relied upon by consumer, and are not a part of the contract for sale or this limited warranty. The USC Warranty Manager is the final decision point for all warranty claims.

5. Return Policy: Approval is required prior to returning goods to Manufacturer irrespective of warranty claim. A restocking fee will apply to all goods that are returned in new, sellable condition. Items returned for warranty that are found to be in new, sellable condition (not failing) will remain the property of the consumer and warranty claim for such items will be denied. The consumer will have the ability to have part returned at the consumer's expense or restocked at 15% restocking fee less any USC paid freight for its return.

6. Entire Obligation: This Limited Warranty states the entire obligation of Manufacturer with respect to the Products. If any part of this Limited Warranty is determined to be void or illegal, the remainder shall remain in full force and effect.

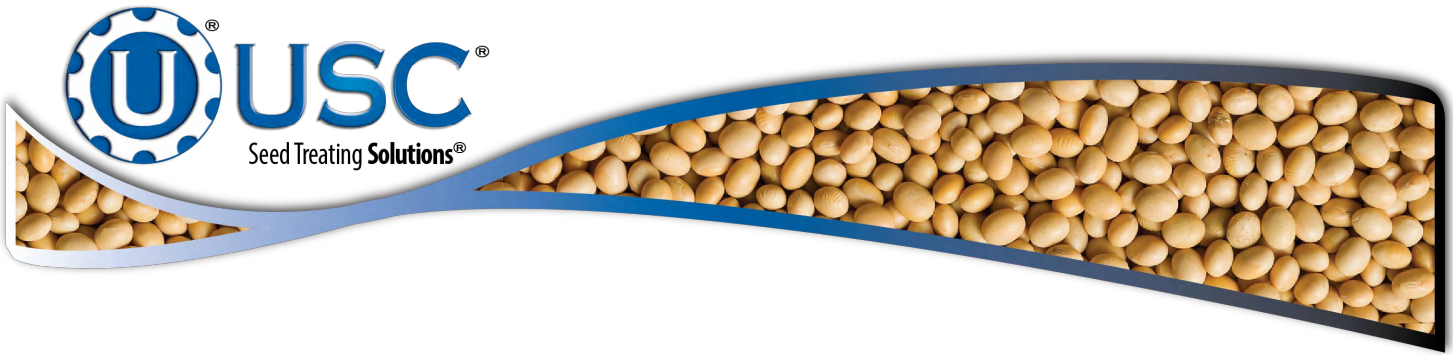

DOCUMENT REVIEW RECORD	
DATE	BY
10-2020	BT

USC, LLC

2320 124th Road

Sabetha, KS 66534

EMAIL: sales-team@uscllc.com

WEB: www.uscllc.com