

UNDERBIN CONVEYOR

EQUIPMENT REVISION: 02B



Parts Manual

Document: MD-09-06-5013

Revision: B Effective Date: 08-2020



INTRODUCTION

Thank you for choosing USC, LLC for your equipment needs. We appreciate your business and will work diligently to ensure that you are satisfied with your choice.

OVERVIEW

The purpose of this manual is to provide you with the basic information needed to operate and maintain the Underbin Conveyor. It does not hold USC, LLC liable for any accidents or injuries that may occur.

The technical information provided in this document is based on extensive testing under controlled conditions at the USC research and development facility. This information is given without guarantee as the conditions of operation and storage of the equipment are beyond our control. Variables such as temperature, humidity, viscosity of chemical products and changes in seed size or variety may all effect the accuracy of application and seed coverage. Periodically check the equipment calibration while treating and make adjustments as required. This will insure the optimum seed coverage.

RECEIVING YOUR EQUIPMENT

As soon as the equipment is received, it should be carefully inspected to make certain that it has sustained no damage during shipment and that all items listed on the packing list are accounted for. If there is any damage or shortages, the purchaser must immediately notify USC, LLC. Ownership passes to purchaser when the unit leaves the USC, LLC. premises. The purchaser is responsible for unloading and mounting all components of the equipment.

Document the serial number of the machine for future reference. The serialization label is located on the head assembly of the conveyor near the belt drive cover.

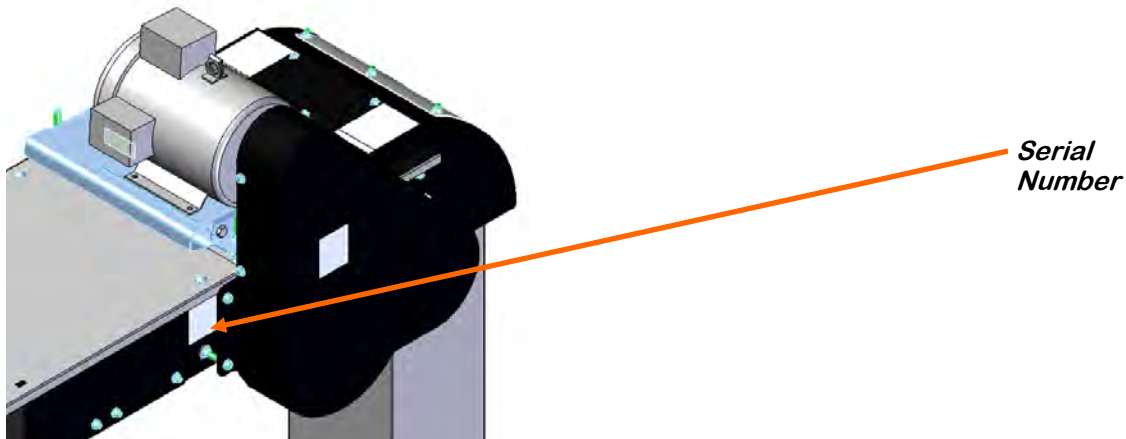

SERIAL NUMBER: _____

TABLE OF CONTENTS

<u>Section</u>	<u>Contents</u>	<u>Page #</u>
Section A	Safety Instructions	4
Section B	Mechanical Drawings	15
	Index by Part Number.....	71
Section C	Limited Warranty	74

SECTION **SAFETY INSTRUCTIONS**
A

Every year accidents in the work place maim, kill and injure people. Although it may be impossible to prevent all accidents, with the right combination of training, operating practices, safety devices and operator vigilance, the number of accidents can be significantly reduced. The purpose of this section is to educate equipment users about hazards, unsafe practices and recommended hazard avoidance techniques.

SAFETY WORDS AND SYMBOLS

It is very important that operators and maintenance personnel understand the words and symbols that are used to communicate safety information. Safety words, their meaning and format, have been standardized for U.S. manufacturers and published by the American National Standards Institute (ANSI). The European Community (E.C.) has adopted a different format based on the International Standards Organization (I.S.O.) and applicable machinery directives. Both formats are presented below. Graphic symbols are not standardized but most manufacturers will use some variation of the ones seen in this manual.



Indicates an imminently hazardous situation which, if not avoided, **will** result in death or serious injury.



Indicates a potentially hazardous situation which, if not avoided, **could** result in death or serious injury.



Indicates a potentially hazardous situation which, if not avoided, **may** result in minor or moderate injury and/or property damage.



Provides additional information that the operator needs to be aware of to avoid a potentially hazardous situation.

UNBERBIN CONVEYOR

YOU are responsible for the **SAFE** operation and maintenance of your USC, LLC equipment . **YOU** must ensure that you and anyone else who is going to operate, maintain or work around the equipment be familiar with the operating and maintenance procedures and related **SAFETY** information contained in this manual. This manual will take you step-by-step through your working day and alert you to good safety practices that should be adhered to while operating the equipment

Remember, **YOU** are the key to safety. Good safety practices not only protect you, but also the people around you. Make these practices a working part of your safety program. Be certain that **EVERYONE** operating this equipment is familiar with the recommended operating and maintenance procedures and follows all the safety precautions. Most accidents can be prevented. Do not risk injury or death by ignoring good safety practices.

- Equipment owners must give operating instructions to operators or employees before allowing them to operate the machine, and at least annually thereafter per OSHA (Occupational Safety and Health Administration) regulation 1928.57.
- The most important safety device on this equipment is a **SAFE** operator. It is the operator's responsibility to read and understand **ALL** Safety and Operating instructions in the manual and to follow them. All accidents can be avoided.
- A person who has not read and understood all operating and safety instructions is not qualified to operate the machine. An untrained operator exposes himself and bystanders to possible serious injury or death.
- Do not modify the equipment in any way. Unauthorized modification may impair the function and/or safety and could affect the life of the equipment.
- Think SAFETY! Work SAFELY!

GENERAL SAFETY

1. Read and understand the operator's manual and all safety labels before operating, maintaining, adjusting or unplugging the equipment .
2. Only trained persons shall operate the equipment . An untrained operator is not qualified to operate the machine.
3. Have a first-aid kit available for use should the need arise, and know how to use it.





Mandatory Lockout Power Symbol. Disconnect, lockout and tagout electrical and other energy sources before inspecting, cleaning or performing maintenance on this panel.



International Safety Alert Symbol. The exclamation point (!) surrounded by a yellow triangle indicates that an injury hazard exists. However, it does not indicate the seriousness of potential injury. The exclamation point (!) is also used with the DANGER, WARNING and CAUTION symbols so the potential injury is indicated.



Electrocution Hazard Symbol. This symbol indicates that an electrocution hazard exists. Serious injury or death could result from contacting high voltage.



International Electrocution Hazard. This symbol indicates that an electrocution hazard exists. Serious injury or death could result from contacting high voltage.



Mandatory Read Manual Action Symbol. (I.S.O. format) This symbol instructs personnel to read the Operators Manual before servicing or operating the equipment.



Mandatory Read Manual Action Symbol. This symbol instructs personnel to read the Operators Manual before servicing or operating the equipment.

NOTICE

Notice is used to notify people of important installation, operation or maintenance information which is not hazard related.

LOCKOUT / TAGOUT PROCEDURES

Lockout/Tagout is the placement of a lock/tag on an energy isolating device in accordance with an established procedure. When taking equipment out of service to perform maintenance or repair work, always follow the lockout/tagout procedures as outlined in OSHA Standard 1910.147. This standard “requires employers to establish a program and utilize procedures for affixing appropriate lockout devices or tagout devices to energy isolating devices and to otherwise disable machines or equipment to prevent unexpected energizing, start-up, or release of stored energy in order to prevent injury to employees.”

CONTROLLED STOP

This is the stopping of machine motion by reducing the electrical command signal to 0 (zero) once the stop signal has been recognized.

HAZARD REVIEW

Electrocution Hazard



Electrocution accidents are most likely to occur during maintenance of the electrical system or when working on or near exposed high voltage wiring. This hazard does not exist when the electrical power has been disconnected, properly locked, and tagged out.

Automatic Start Hazard



This equipment may be controlled by an automated system and may start without warning. Failure to properly disconnect, lockout, and tagout all energy sources of remotely controlled equipment creates a very hazardous situation and could cause injury or even death. PLEASE STAY CLEAR AND BE ALERT.

UNDERBIN CONVEYOR

4. Provide a fire extinguisher for use in case of an accident. Store in a highly visible place.
5. Do not allow children, spectators or bystanders within hazard area of machine.
6. Wear appropriate protective gear. This includes but is not limited to:
 - A hard hat
 - Protective shoes with slip resistant soles
 - Protective goggles
 - Heavy gloves
 - Hearing protection
 - Respirator or filter mask
7. Place all controls in neutral or off, stop motor, and wait for all moving parts to stop. Then disable power source before servicing, adjusting, repairing, or unplugging.
8. Review safety related items annually with all personnel who will be operating or maintaining the equipment.



OPERATING SAFETY:

1. Read and understand the operator's manual and all safety labels before using.
2. Disconnect and disable electrical supply completely and wait for all moving parts to stop before servicing, adjusting, repairing or unplugging.
3. Clear the area of bystanders, especially children, before starting.
4. Be familiar with the machine hazard area. If anyone enters hazard area, shut down machine immediately. Clear the area before restarting.
5. Keep hands, feet, hair and clothing away from all moving and/or rotating parts.
6. Stay away from overhead obstructions and power lines during operation and transporting. Electrocutation can occur without direct contact.
7. Do not operate machine when any guards are removed.
8. Inspect welds and repair if needed.

UNBERBIN CONVEYOR

MAINTENANCE SAFETY

1. Review the operator's manual and all safety items before working with, maintaining or operating the equipment .
2. Place all controls in neutral or off, stop motors, disable power source, and wait for all moving parts to stop before servicing, adjusting, repairing or unplugging.
3. Follow good shop practices:
Keep service area clean and dry.
Be sure electrical outlets and tools are properly grounded.
Use adequate light for the job at hand.
4. Keep hands, feet, hair and clothing away from all moving and/or rotating parts.
5. Clear the area of bystanders, especially children, when carrying out any maintenance and repairs or making any adjustments.
6. Before resuming work, install and secure all guards when maintenance work is completed.
7. Keep safety labels clean. Replace any sign that is damaged or not clearly visible.



UNDERBIN CONVEYOR

SAFETY LABELS

1. Keep safety labels clean and legible at all times.
2. Replace safety labels that are missing or have become illegible.
3. Replaced parts that displayed a safety label should also display the current label.
4. Replacement safety labels are available. Contact your authorized dealer

How to Install Safety Labels:

- Be sure that the installation area is clean and dry.
- Be sure temperature is above 50°F (10°C).
- Decide on the exact position before you remove the backing paper.
- Remove the smallest portion of the split backing paper.
- Align the sign over the specified area and carefully press the small portion with the exposed sticky backing in place.
- Slowly peel back the remaining paper and carefully smooth the remaining portion of the sign in place.
- Small air pockets can be pierced with a pin and smoothed out using the piece of sign backing paper.



Located on the USC equipment you will find safety labels. Always be sure to read and follow all directions on the labels.



Guards provided with USC equipment are to remain in place during operation.

UNBERBIN CONVEYOR

Think **SAFETY!** Work **SAFELY!**

REMEMBER—If safety labels have been damaged, removed, become illegible, or parts replaced without safety labels, new labels must be applied. New safety labels are available from your authorized dealer.



Part # 09-02-0010



Part # 09-02-0009



Part # 09-02-0012

UNDERBIN CONVEYOR

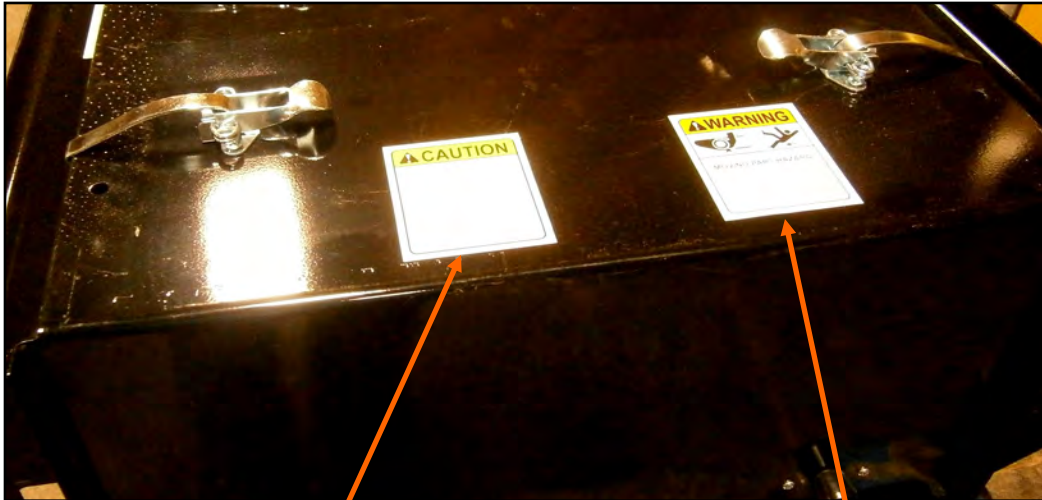

Part # 09-02-0006



Part # 09-02-0011

UNBERBIN CONVEYOR



Part # 09-02-0011



UNDERBIN CONVEYOR



Part # 09-02-0002



Part # 09-02-0001

MECHANICAL DRAWINGS SECTION B

The following pages show the parts of the under bin conveyors. Please have the treater serial number and part number ready when ordering parts.

GENERAL ASSEMBLY

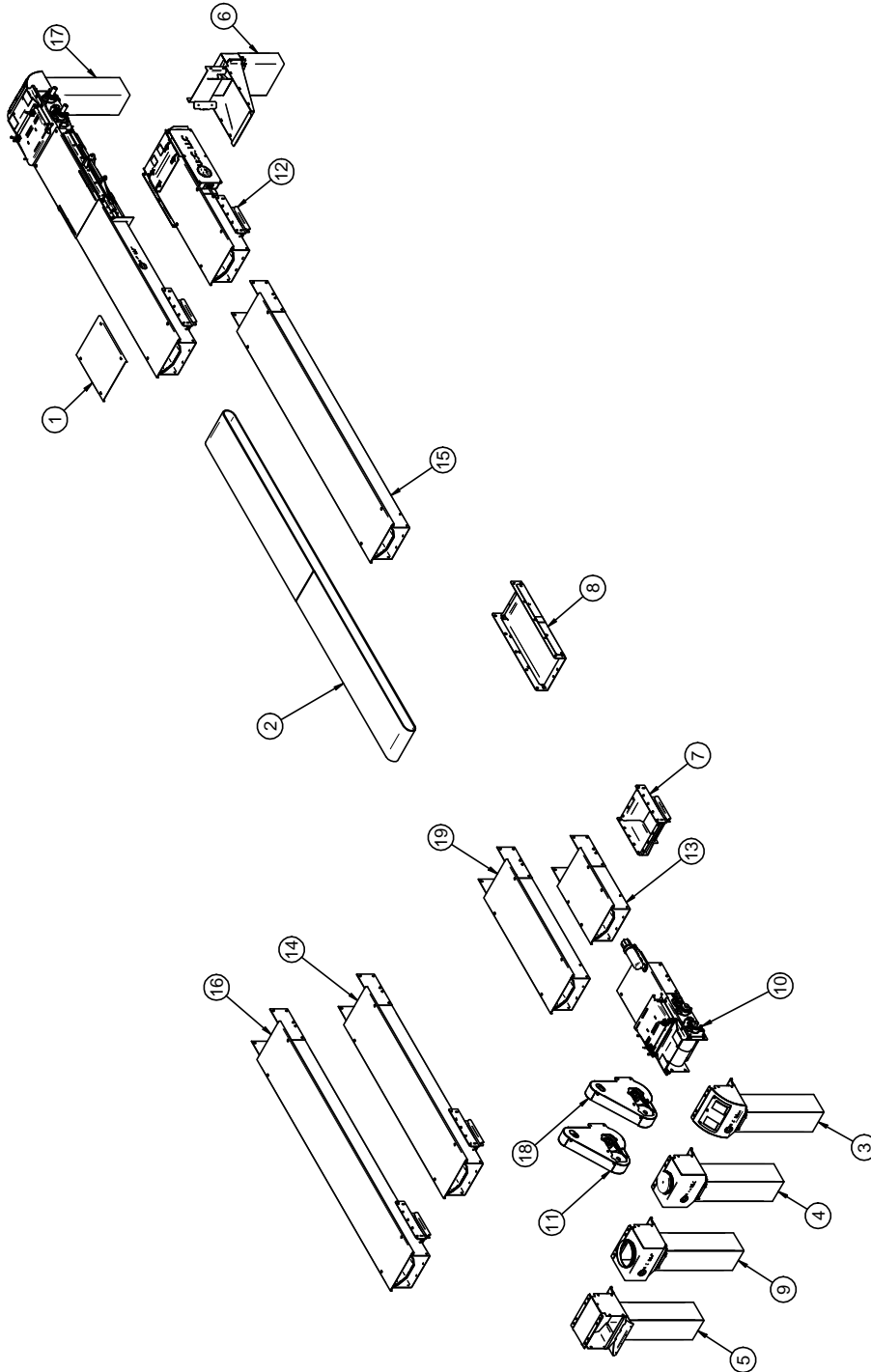

UNDERBIN CONVEYOR

GENERAL ASSEMBLY

PART # GENERAL ASSEMBLY		
Item #	Description	See Page
1	PLT CNVR SPLICE CVR	
2	BELT	47
3	ASSY UB HD	26
4	ASSY UB HD BOX STAND	27
5	ASSY UB HD-HD CONN	29
6	ASSY RVRS UB CHUTE	38
7	KIT UB CLEANOUT	68
8	KIT UB ACCESS DOOR	69
9	ASSY UB HD BOX STAND 10IN	28
10	ASSY UB HD SECT LG BRG	18
11	KIT DRV 7.5 & 10 HP 6.5IN DRV PLY	25
12	ASSY UB TAIL SECT	36
13	ASSY UB INTER 2.5FT	31
14	ASSY UB INTER 7.5FT W/CLNOUT	33
15	ASSY UB INTER 10FT	34
16	ASSY UB INTER 10FT W/CLNOUT	35
17	ASSY DUAL UB RVRS DSCHG W/CLNOUT	39
18	KIT DRV 5 HP 6.5IN DRV PLY	24
19	ASSY UB INTER 5.0FT	32

MOTOR KITS

MOTOR KITS			
VOLTAGE	5 HP	10 HP	10 HP DUAL
240V / 1PH	01-01-0107	01-01-0131	N/A
240V / 3PH	01-01-0151	01-01-0291	01-01-0152
480V / 3PH	01-01-0151	01-01-0291	01-01-0152
575V / 3PH	01-01-0143	01-01-0173	01-01-0173
380 - 415 V / 3PH	01-01-0209	01-01-0220	01-01-0220
LENGTH	T0 72.5 FT	75 TO 122.5 FT	125 TO 175 FT

UNBERBIN CONVEYOR

ASSEMBLY UB HEAD SECTION LARGE BEARING (13-08-0757 REV B0)

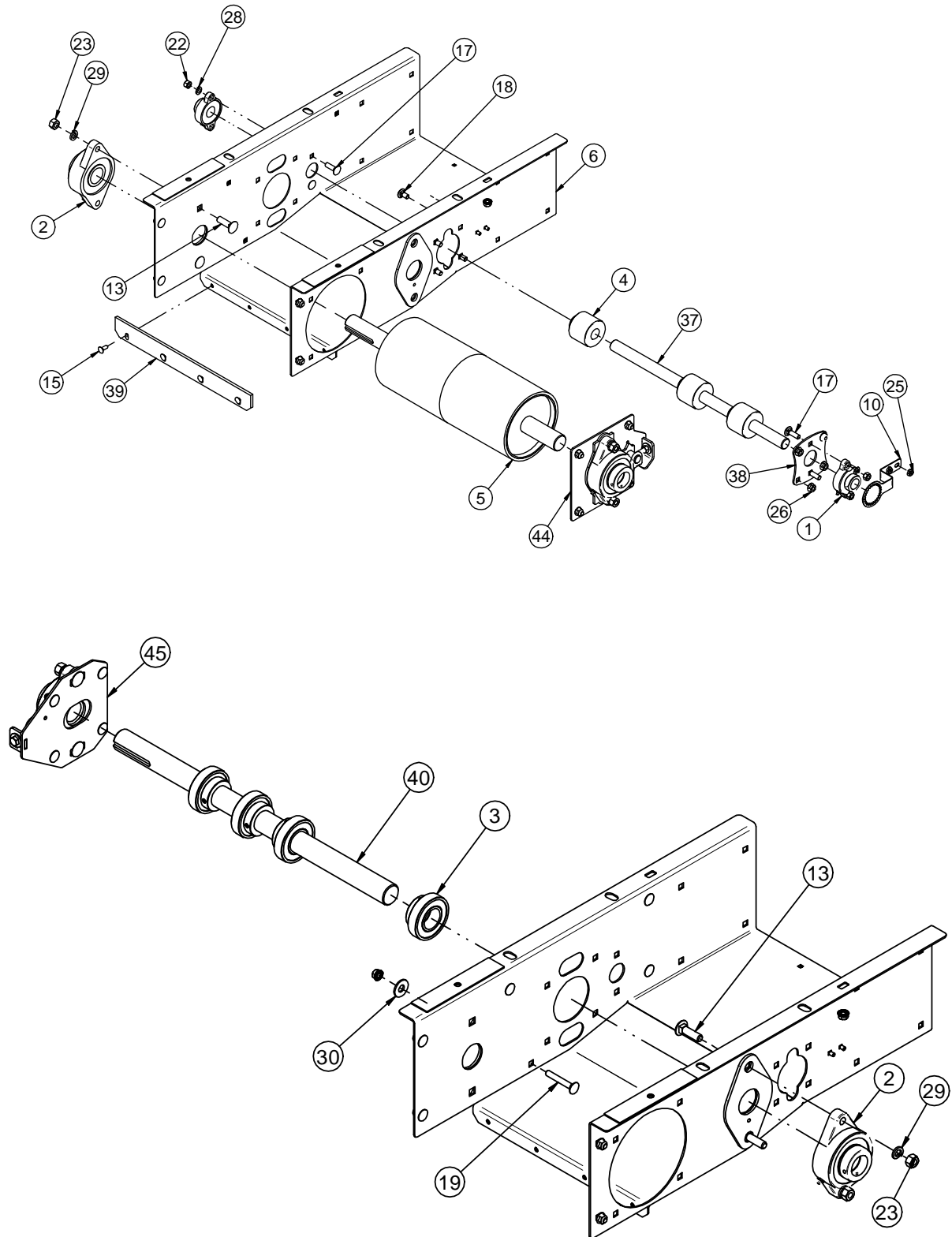

UNDERBIN CONVEYOR

ASSEMBLY UB HEAD SECTION LARGE BEARING (13-08-0757 REV B0)

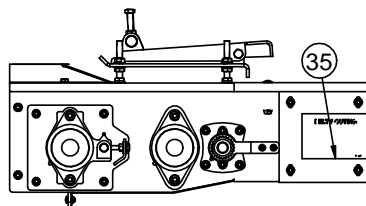
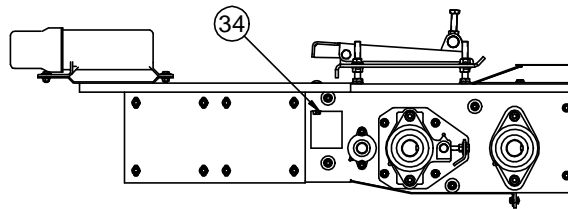
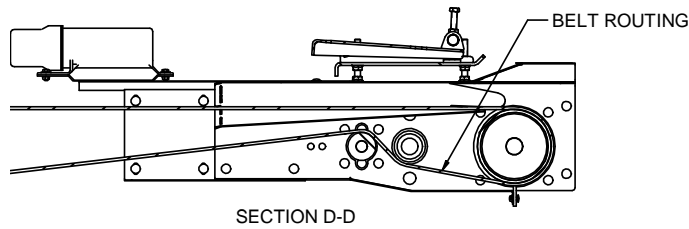
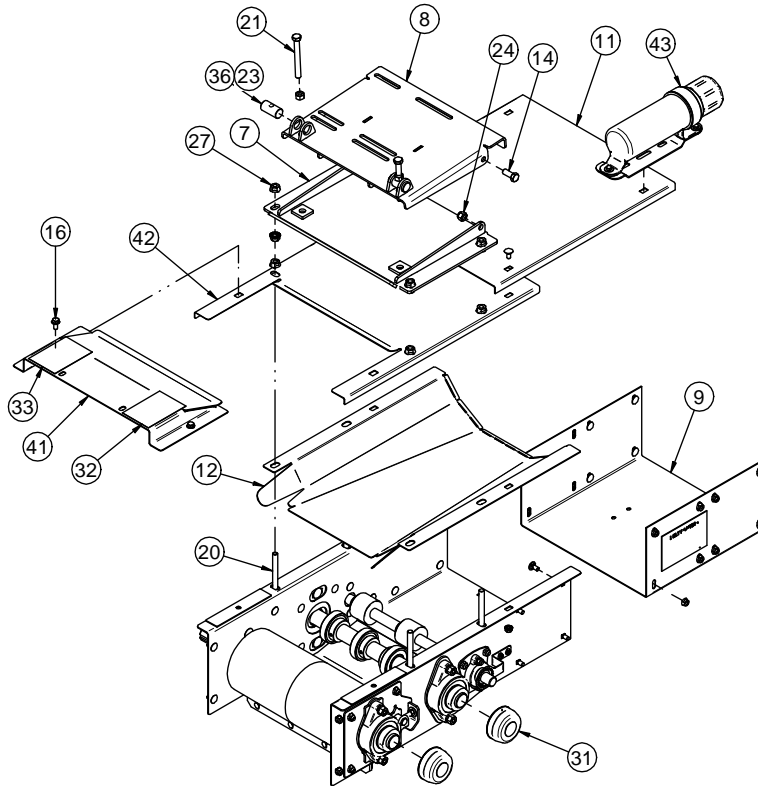

UNBERBIN CONVEYOR

ASSEMBLY UB HEAD SECTION LARGE BEARING (13-08-0757 REV B0)

PART #		13-08-0757 REV B2		
Item #	Part #	Description	Qty	See Page
1	01-03-0042	BRG FLG MNT 1.000ID 2BOLT ECNTRC	2	
2	01-03-0077	BRG FLG MNT 1.500ID 2BOLT ECNTRC	2	
3	01-03-0082	BRG BALL 1.50ID X 3.146OD	4	
4	01-06-0176	WHL DRV 2.50 X 2 X 1.00ID	3	
5	01-08-0138	PULLEY HEAD 6.50 DIA X 15.50L 1.5IN	1	
6	05-08-0725	WDMT UB HD SECT	1	
7	05-08-0730	WDMT MTR BASE PLT	1	
8	05-08-0731	WDMT MTR MNT PLT UB	1	
9	05-10-2935	SPLICE PLATE-FORMED UB	1	
10	05-10-3508	BRKT ECDR 25T TEATHER ARM UBD	1	
11	05-10-3510	PLT CNVR SPLICE CVR	1	
12	05-10-5075	PLT TRANS UB	1	
13	06-01-0026	BOLT CRG .500-13 X 1.75 ZP GR5	4	
14	06-01-0080	BOLT .500-13 X 1.25 ZP GR5	2	
15	06-01-0122	BOLT CRG .250-20 X .750 ZP GR5	4	
16	06-01-0124	BOLT FLG .375-16 X .750 ZP GR5	2	
17	06-01-0127	BOLT CRG .375-16 X 1.25 ZP GR5	4	
18	06-01-0153	BOLT CRG .375-16X.750 ZP SHORT NECK	26	
19	06-01-0154	BOLT CRG .375-16 X 2.50 ZP	4	
20	06-01-0157	BOLT .500-13 X 4.00 ZP GR5 FTH	4	
21	06-01-0221	BOLT .500-13 X 4.50 ZP GR5 FTH	2	
22	06-02-0003	NUT FULL .375-16 ZP GR5	4	
23	06-02-0004	NUT FULL .500-13 ZP GR5	6	
24	06-03-0004	NUT NYL LOCK .500-13 ZP GR5	2	
25	06-03-0013	NUT LOCK FLG .250-20 ZP GR5	6	
26	06-03-0014	NUT LOCK FLG .375-16 ZP GR5	30	
27	06-03-0015	NUT LOCK FLG .500-13 ZP GR5	12	
28	06-04-0003	WSHR LOCK SPLT .375 ZP	4	
29	06-04-0004	WSHR LOCK SPLT .500 ZP	4	
30	06-05-0005	WSHR FLAT .500 ZP	4	
31	06-10-0080	CVR SNAP-ON 208 BRG	2	
32	09-02-0001	ATWK LBL DANGER FINGERS	1	
33	09-02-0002	ATWK LBL DANGER GRD	1	
34	09-02-0011	ATWK LBL WARNING MOVING PART	1	
35	09-02-0038	LBL ATWK BELT ROUTING UB HD	1	
36	10414A	PIN MTR PIVOT	2	

UNDERBIN CONVEYOR

ASSEMBLY UB HEAD SECTION LARGE BEARING (13-08-0757 REV B0)

PART #		13-08-0757 REV B2		
Item #	Part #	Description	Qty	See Page
37	105B3B	SHAFT ENCODER DRV	1	
38	105C44	PLT BRG MNT	1	
39	105C4C	RBBR SCRAPER UB	1	
40	105C4F	SHAFT 25.25 X 1.50" JACK-HEAD	1	
41	106447	COVER UB HD	1	
42	106448	COVER HD SECT UB	1	
43	13-05-0332	ASSY MANUAL TUBE MNT	1	29
44	13-08-0758	ASSY TRACKING PLT	1	21
45	13-08-0759	ASSY TRACKING PLT SM	1	22

UNBERBIN CONVEYOR

ASSEMBLY TRACKING PLATE (13-08-0758 REV A0)

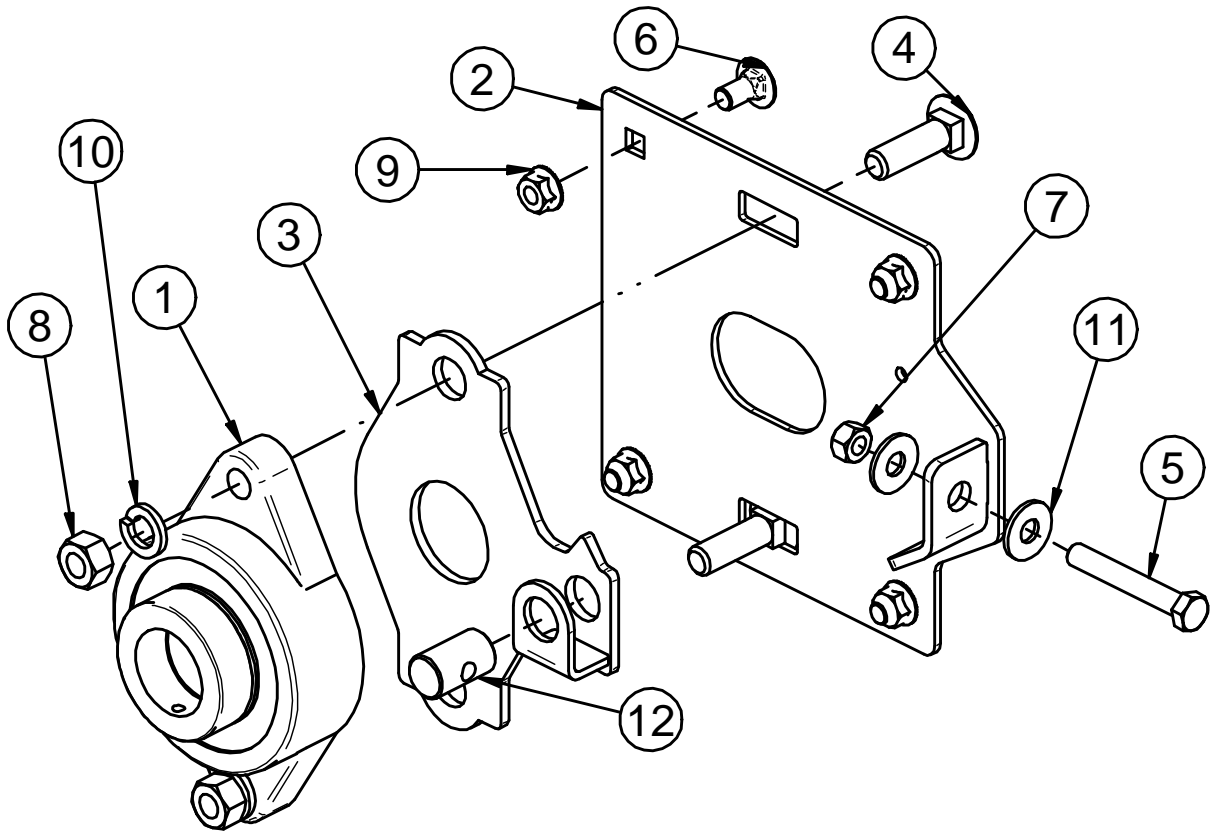

PART #		13-08-0758 REV A0	
Item #	Part #	Description	Qty
1	01-03-0077	BRG FLG MNT 1.500ID 2BOLT ECNTRC	1
2	05-08-0724	WDMT TRACKING MNT	1
3	05-08-0726	WDMT TRACKING SLIDE	1
4	06-01-0026	BOLT CRG .500-13 X 1.75 ZP GR5	2
5	06-01-0071	BOLT .375-16 X 2.50 ZP GR5	1
6	06-01-0153	BOLT CRG .375-16X.750 ZP SHORT NECK	4
7	06-02-0003	NUT FULL .375-16 ZP GR5	1
8	06-02-0004	NUT FULL .500-13 ZP GR5	2
9	06-03-0014	NUT LOCK FLG .375-16 ZP GR5	4
10	06-04-0004	WSHR LOCK SPLT .500 ZP	2
11	06-05-0004	WSHR FLAT .375 ZP	2
12	104079	PIN TRACKING PIVOT	1

UNDERBIN CONVEYOR

ASSEMBLY TRACKING PLATE SMALL (13-08-0759 REV A0)

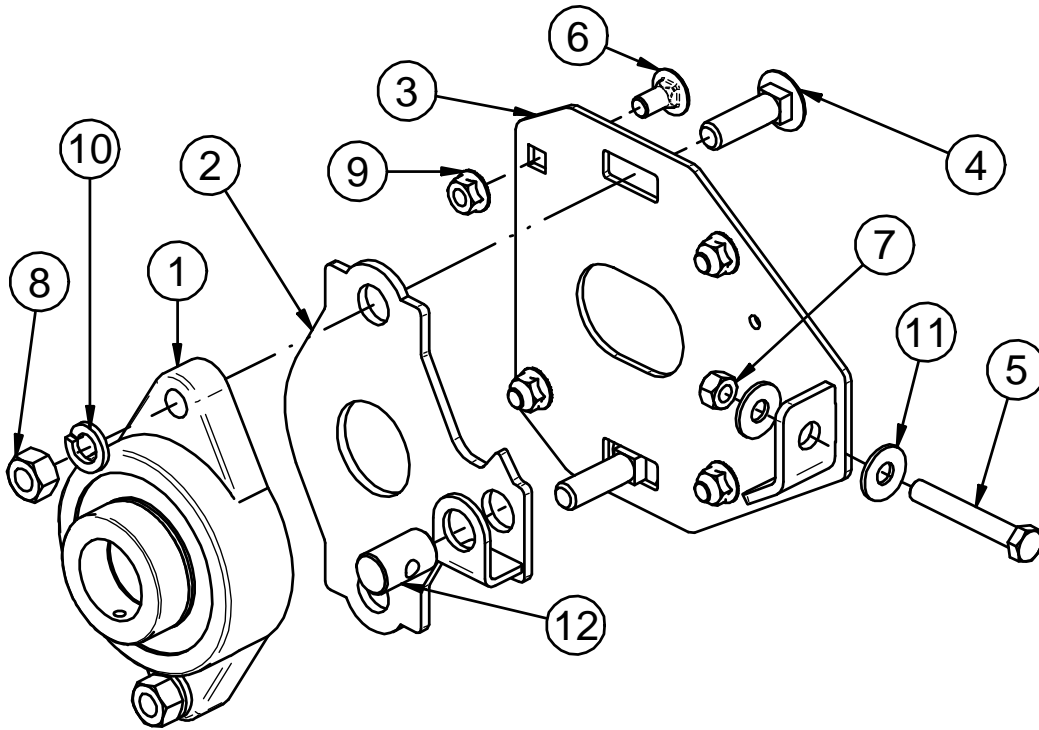

PART #		13-08-0759 REV A0	
Item #	Part #	Description	Qty
1	01-03-0077	BRG FLG MNT 1.500ID 2BOLT ECNTRC	1
2	05-08-0726	WDMT TRACKING SLIDE	1
3	05-08-0727	WDMT TRACKING MNT SM	1
4	06-01-0026	BOLT CRG .500-13 X 1.75 ZP GR5	2
5	06-01-0071	BOLT .375-16 X 2.50 ZP GR5	1
6	06-01-0153	BOLT CRG .375-16X.750 ZP SHORT NECK	4
7	06-02-0003	NUT FULL .375-16 ZP GR5	1
8	06-02-0004	NUT FULL .500-13 ZP GR5	2
9	06-03-0014	NUT LOCK FLG .375-16 ZP GR5	4
10	06-04-0004	WSHR LOCK SPLT .500 ZP	2
11	06-05-0004	WSHR FLAT .375 ZP	2
12	104079	PIN TRACKING PIVOT	1

UNBERBIN CONVEYOR

DRIVE KIT 5 HP 6.5 IN PULLEY (13-08-0855 REV A1)

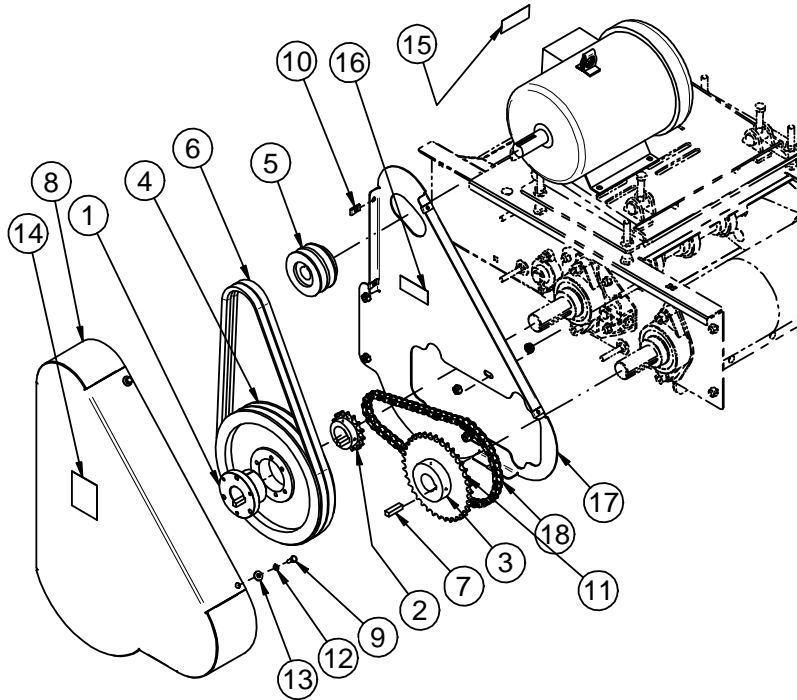

PART #		13-08-0855 REV A1	
Item #	Part #	Description	Qty
1	01-02-0143	BUSH 1.50IN BORE TYPE SK	1
2	01-02-0145	SPKT 15T 50P 1.50ID KWY	1
3	01-02-0146	SPKT 36T 50P 1.50ID KWY	1
4	01-08-0087	SHV 2B110SK	1
5	01-08-0122	SHV 2BK36 X 1.125 FHSB BORE	1
6	01-08-0139	BELT BX52	2
7	01-10-0015	KEY .375 X 1.50 CS	3
8	05-08-0729	WDMT BELT DRIVE COVER	1
9	06-01-0006	BOLT .250-20 X .750 ZP GR5	6
10	06-02-0047	NUT U-CLIP .250-20	6
11	06-03-0014	NUT LOCK FLG .375-16 ZP GR5	8
12	06-04-0001	WSHR LOCK SPLT .250 ZP	6
13	06-05-0001	WSHR FLAT .250 ZP	6
14	09-02-0009	ATWK LBL WARNING ROTATING PARTS	1
15	09-02-0010	ATWK LBL DANGER ELECTROCUTION	1
16	09-02-0012	ATWK LBL DANGER MISSING SHIELD	1
17	105C47	PLT BACK BELT COVER	1
18	105C4A	ASSY RC- 50 55-LINKS (34 3/8")	1

UNDERBIN CONVEYOR

DRIVE KIT 7.5 & 10 HP 6.5 IN PULLEY (13-08-0760 REV A2)

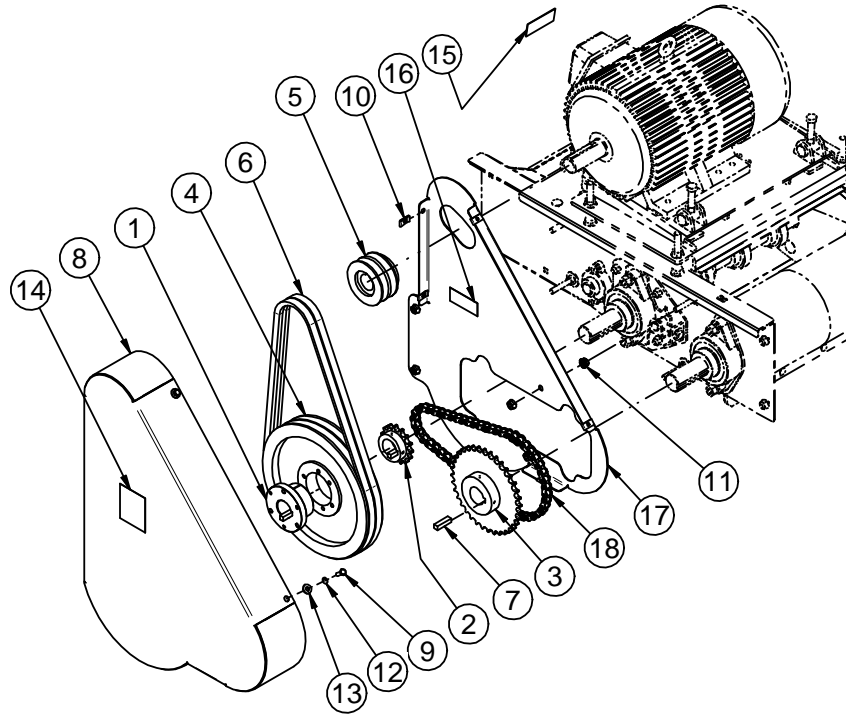

PART #		13-08-0760 REV A2	
Item #	Part #	Description	Qty
1	01-02-0143	BUSH 1.50IN BORE TYPE SK	1
2	01-02-0145	SPKT 15T 50P 1.50ID KWY	1
3	01-02-0146	SPKT 36T 50P 1.50ID KWY	1
4	01-08-0087	SHV 2B110SK	1
5	01-08-0119	SHV 2BK36 X 1.375 FSH BORE	1
6	01-08-0139	BELT BX52	2
7	01-10-0015	KEY .375 X 1.50 CS	3
8	05-08-0729	WDMT BELT DRIVE COVER	1
9	06-01-0006	BOLT .250-20 X .750 ZP GR5	6
10	06-02-0047	NUT U-CLIP .250-20	6
11	06-03-0014	NUT LOCK FLG .375-16 ZP GR5	8
12	06-04-0001	WSHR LOCK SPLT .250 ZP	6
13	06-05-0001	WSHR FLAT .250 ZP	6
14	09-02-0009	ATWK LBL WARNING ROTATING PARTS	1
15	09-02-0010	ATWK LBL DANGER ELECTROCUTION	1
16	09-02-0012	ATWK LBL DANGER MISSING SHIELD	1
17	105C47	PLT BACK BELT COVER	1
18	105C4A	ASSY RC- 50 55-LINKS (34 3/8")	1

UNBERBIN CONVEYOR

ASSEMBLY UB HEAD (ST) (13-05-0674 REV A1)

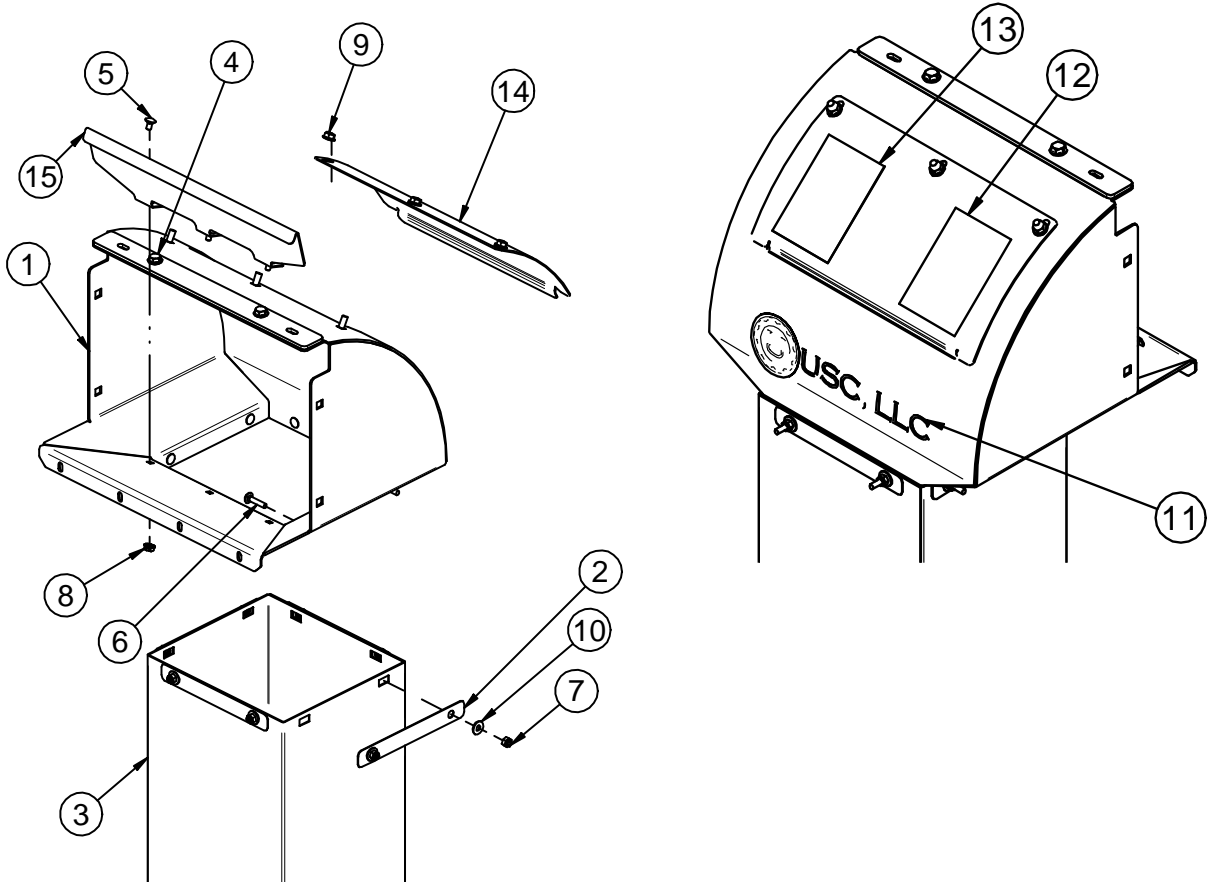

PART #		13-05-0674 REV A1	
Item #	Part #	Description	Qty
1	05-08-0728	WDMT DISCHG SPOUT 1-UB	1
2	05-10-3311	PLT UB DUAL DSCHG HOPP EXT HLDR	4
3	05-10-3534	PLT UB HORIZ DSCHG EXT RBBR	1
4	06-01-0124	BOLT FLG .375-16 X .750 ZP GR5	2
5	06-01-0150	BOLT CRG .250-20 X .500 ZP	3
6	06-01-0159	BOLT CRG .250-20 X 1.25 ZP GR5	8
7	06-03-0001	NUT NYL LOCK .250-20 ZP GR5	8
8	06-03-0013	NUT LOCK FLG .250-20 ZP GR5	3
9	06-03-0019	NUT LOCK FLG .313-18 ZP GR5	3
10	06-05-0001	WSHR FLAT .250 ZP	8
11	09-01-0042	ATWK LBL USC 11.50 X 3.00 PRO-CUT	1
12	09-02-0001	ATWK LBL DANGER FINGERS	1
13	09-02-0002	ATWK LBL DANGER GRD	1
14	105C4E	PLT INSP CVR UB	1
15	105C54	DEFLECTOR SEED	1

UNDERBIN CONVEYOR

ASSEMBLY UB HEAD BOX STAND 8IN (BX) (13-05-0675 REV A1)

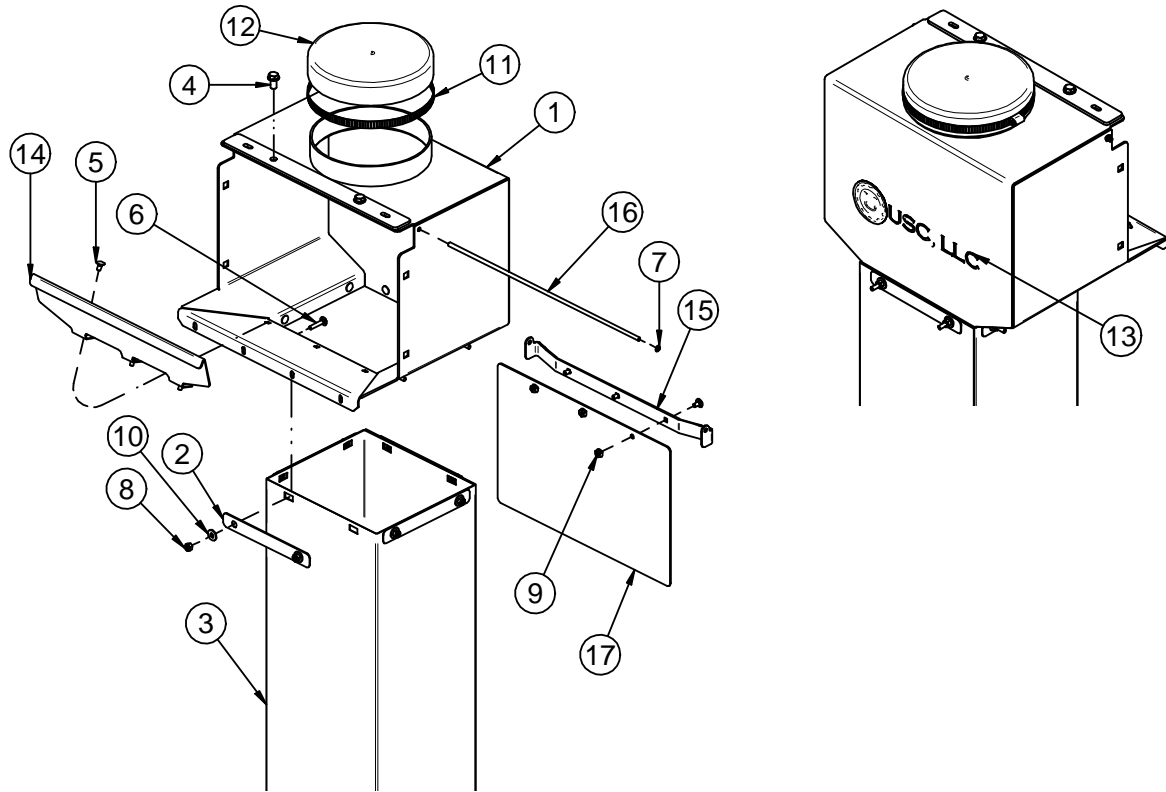

PART #		13-05-0675 REV A1	
Item #	Part #	Description	Qty
1	05-08-0733	WDMT DISCHG SPOUT 2-UB	1
2	05-10-3311	PLT UB DUAL DSCHG HOPP EXT HLDR	4
3	05-10-3534	PLT UB HORIZ DSCHG EXT RBBR	1
4	06-01-0124	BOLT FLG .375-16 X .750 ZP GR5	4
5	06-01-0150	BOLT CRG .250-20 X .500 ZP	6
6	06-01-0159	BOLT CRG .250-20 X 1.25 ZP GR5	8
7	06-02-0100	NUT PUSH 1/4 UNTHREADED SHAFT	2
8	06-03-0001	NUT NYL LOCK .250-20 ZP GR5	8
9	06-03-0013	NUT LOCK FLG .250-20 ZP GR5	6
10	06-05-0001	WSHR FLAT .250 ZP	8
11	06-07-0024	CLMP HOSE 7.125 TO 10 X 9/16 SS	1
12	06-10-0076	SEAL VINYL CAP 8.00ID X 1.50H	1
13	09-01-0042	ATWK LBL USC 11.50 X 3.00 PRO-CUT	1
14	105C54	DEFLECTOR SEED	1
15	105C79	PLT FORMED PIVOT	1
16	105C7D	ROD DEFLECTOR PIVOT	1
17	105C89	DEFLECTOR PIVOT	1

UNBERBIN CONVEYOR

ASSEMBLY UB HEAD BOX STAND 10IN (CV) (13-05-0845 REV A0)

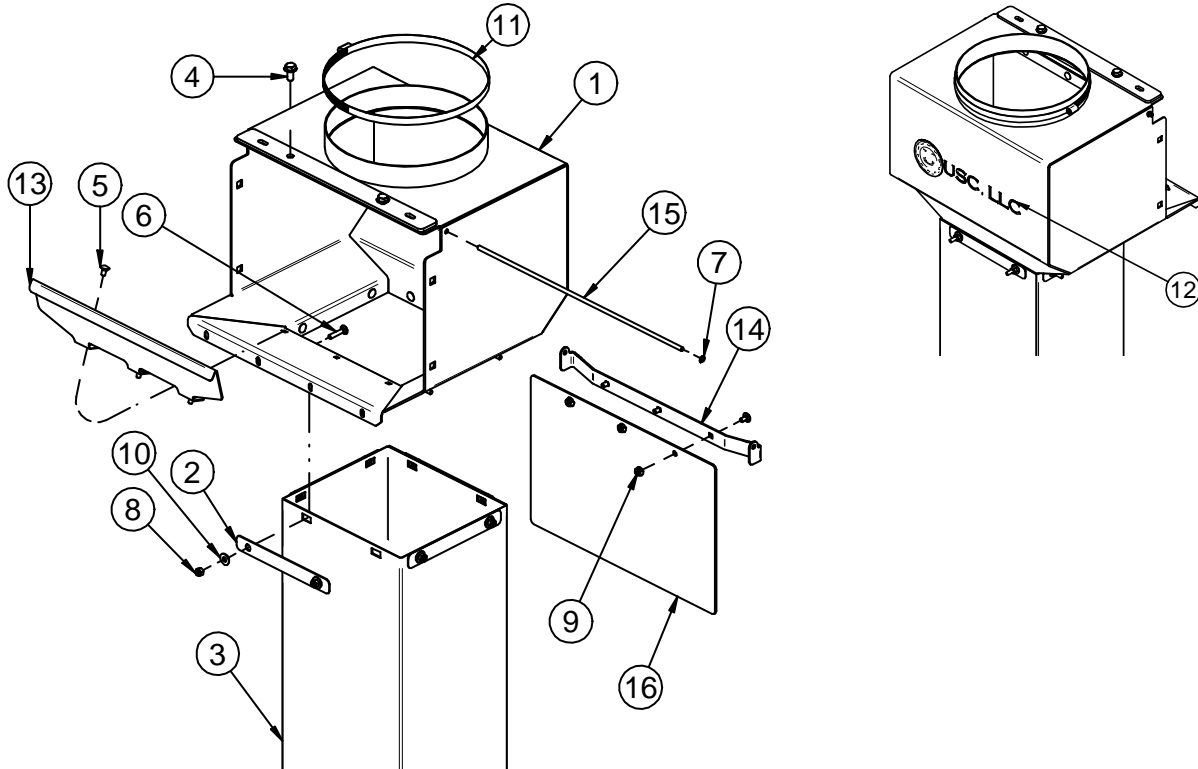

PART #		13-05-0845 REV A0	
Item #	Part #	Description	Qty
1	05-08-0855	WDMT DISCHG SPOUT 2-UB	1
2	05-10-3311	PLT UB DUAL DSCHG HOPP EXT HLDR	4
3	05-10-3534	PLT UB HORIZ DSCHG EXT RBBR	1
4	06-01-0124	BOLT FLG .375-16 X .750 ZP GR5	2
5	06-01-0150	BOLT CRG .250-20 X .500 ZP	6
6	06-01-0159	BOLT CRG .250-20 X 1.25 ZP GR5	8
7	06-02-0100	NUT PUSH 1/4 UNTHREADED SHAFT	2
8	06-03-0001	NUT NYL LOCK .250-20 ZP GR5	8
9	06-03-0013	NUT LOCK FLG .250-20 ZP GR5	6
10	06-05-0001	WSHR FLAT .250 ZP	8
11	06-07-0027	CLMP HOSE 9.375 TO 12.25 X 9/16 SS	1
12	09-01-0042	ATWK LBL USC 11.50 X 3.00 PRO-CUT	1
13	105C54	DEFLECTOR SEED	1
14	105C79	PLT FORMED PIVOT	1
15	105C7D	ROD DEFLECTOR PIVOT	1
16	105C89	DEFLECTOR PIVOT	1

UNDERBIN CONVEYOR

ASSEMBLY UB HEAD TO HEAD CONNECTOR (DH) (13-05-0676 REV A2)

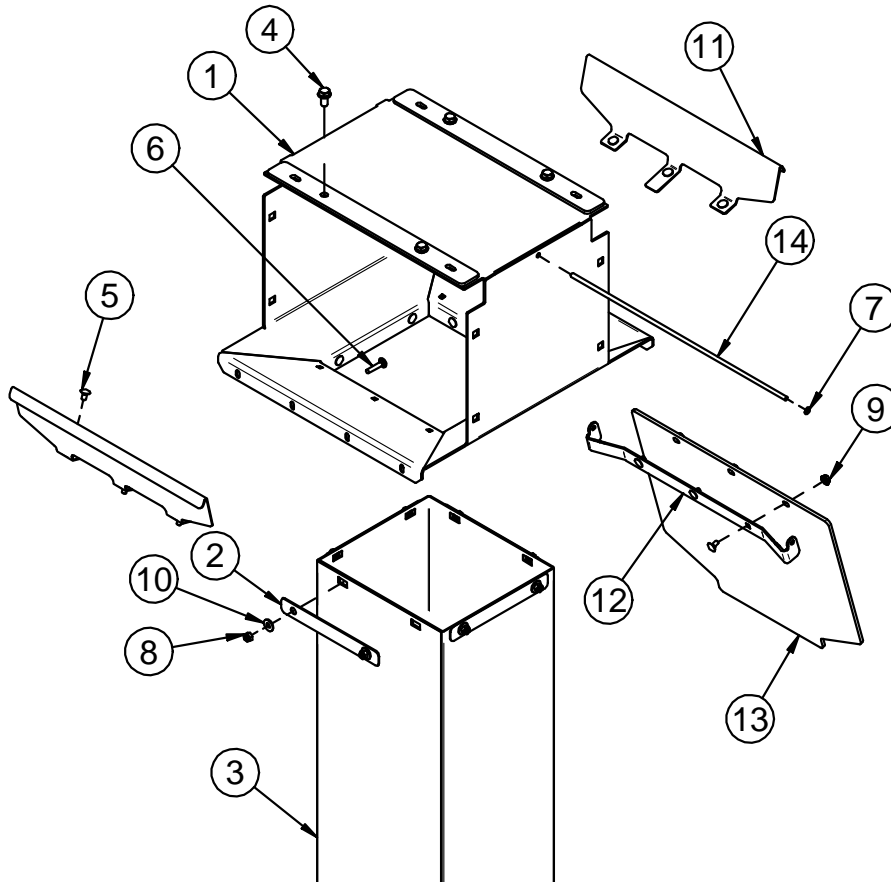

PART #		13-05-0676 REV A2	
Item #	Part #	Description	Qty
1	05-08-0732	WDMT DISCHG SPOUT 3-UB	1
2	05-10-3311	PLT UB DUAL DSCHG HOPP EXT HLDR	4
3	05-10-3534	PLT UB HORIZ DSCHG EXT RBBR	1
4	06-01-0124	BOLT FLG .375-16 X .750 ZP GR5	4
5	06-01-0150	BOLT CRG .250-20 X .500 ZP	9
6	06-01-0159	BOLT CRG .250-20 X 1.25 ZP GR5	8
7	06-02-0100	NUT PUSH 1/4 UNTHREADED SHAFT	2
8	06-03-0001	NUT NYL LOCK .250-20 ZP GR5	8
9	06-03-0013	NUT LOCK FLG .250-20 ZP GR5	9
10	06-05-0001	WSHR FLAT .250 ZP	8
11	105C54	DEFLECTOR SEED	2
12	105C79	PLT FORMED PIVOT	1
13	105C7C	DEFLECTOR PIVOT	1
14	105C7D	ROD DEFLECTOR PIVOT	1

UNBERBIN CONVEYOR

ASSEMBLY MANUAL TUBE (13-05-0332 REV A0)

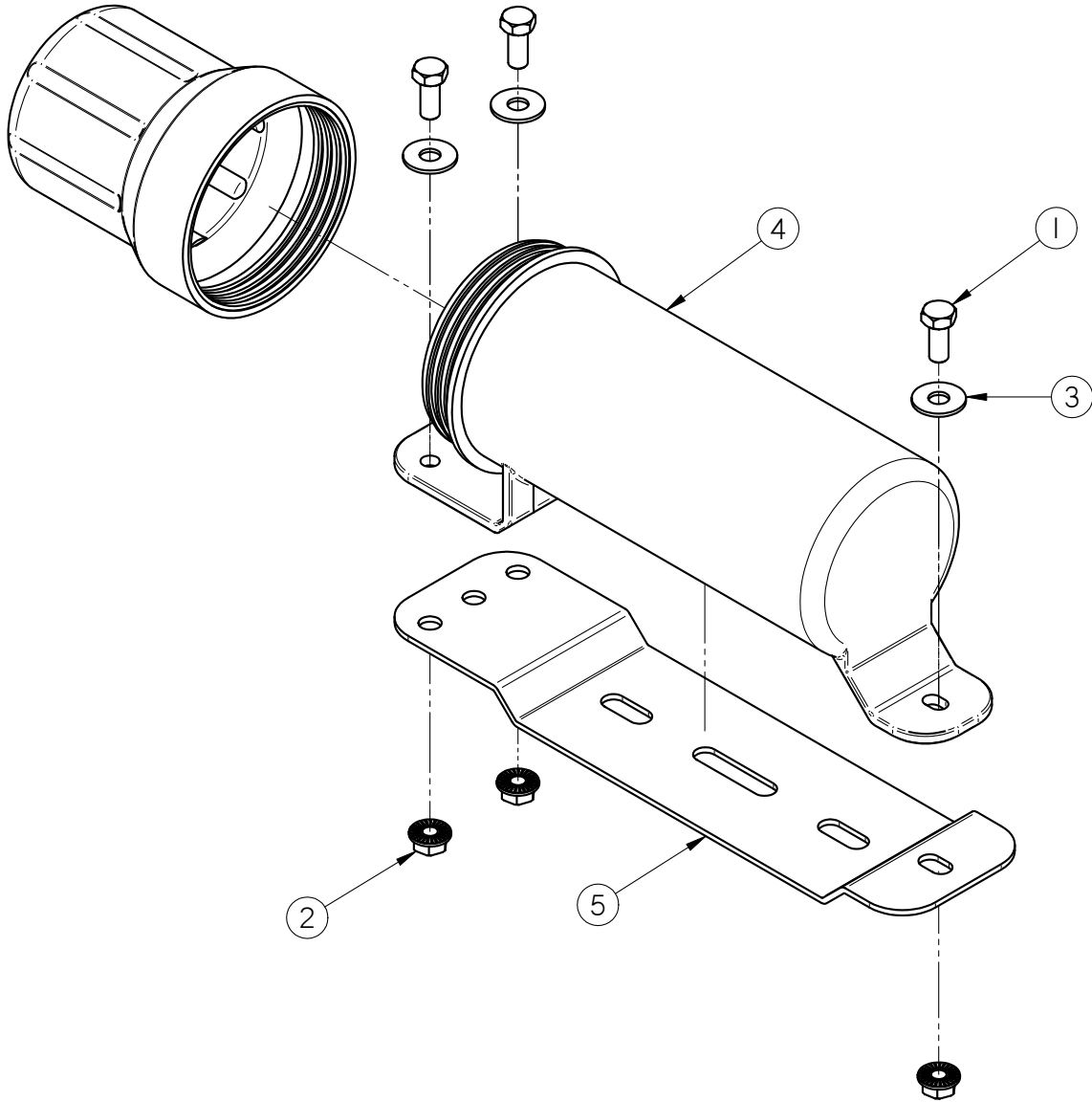

PART #		13-05-0332 REV A0	
Item #	Part #	Description	Qty
1	06-01-0010	BOLT .313-18 X .750 ZP GR5	3
2	06-03-0019	NUT LOCK FLG .313-18 ZP GR5	3
3	06-05-0011	WSHR FLAT .313 X .875OD SS 18-8	3
4	08-07-0050	HOLDER MANUAL 3.25 DIA	1
5	103980	PLT MANUAL MOUNT	1

UNDERBIN CONVEYOR

ASSEMBLY UB INTERMEDIATE 2.5FT (13-08-0767 REV A0)

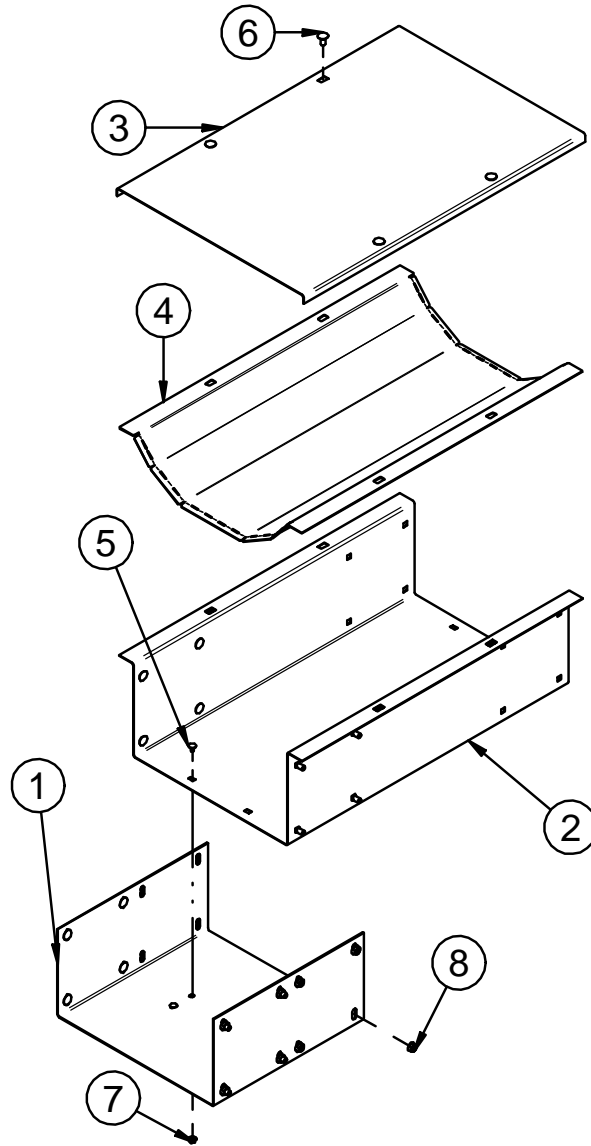

PART #		13-08-0767 REV A0	
Item #	Part #	Description	Qty
1	05-10-2935	SPLICE PLATE-FORMED UB	1
2	05-10-2949	FRM 2.5FT MID SECTION UB CNVR	1
3	05-10-2953	TOP COVER 2.5 FT SECTION UB	1
4	05-10-4647	TROUGH PAN 2.5FT SECT	1
5	06-01-0150	BOLT CRG .250-20 X .500 ZP	4
6	06-01-0153	BOLT CRG .375-16X.750 ZP SHORT NECK	20
7	06-03-0013	NUT LOCK FLG .250-20 ZP GR5	4
8	06-03-0014	NUT LOCK FLG .375-16 ZP GR5	20

UNBERBIN CONVEYOR

ASSEMBLY UB INTERMEDIATE 5.0FT (13-08-0866 REV A0)

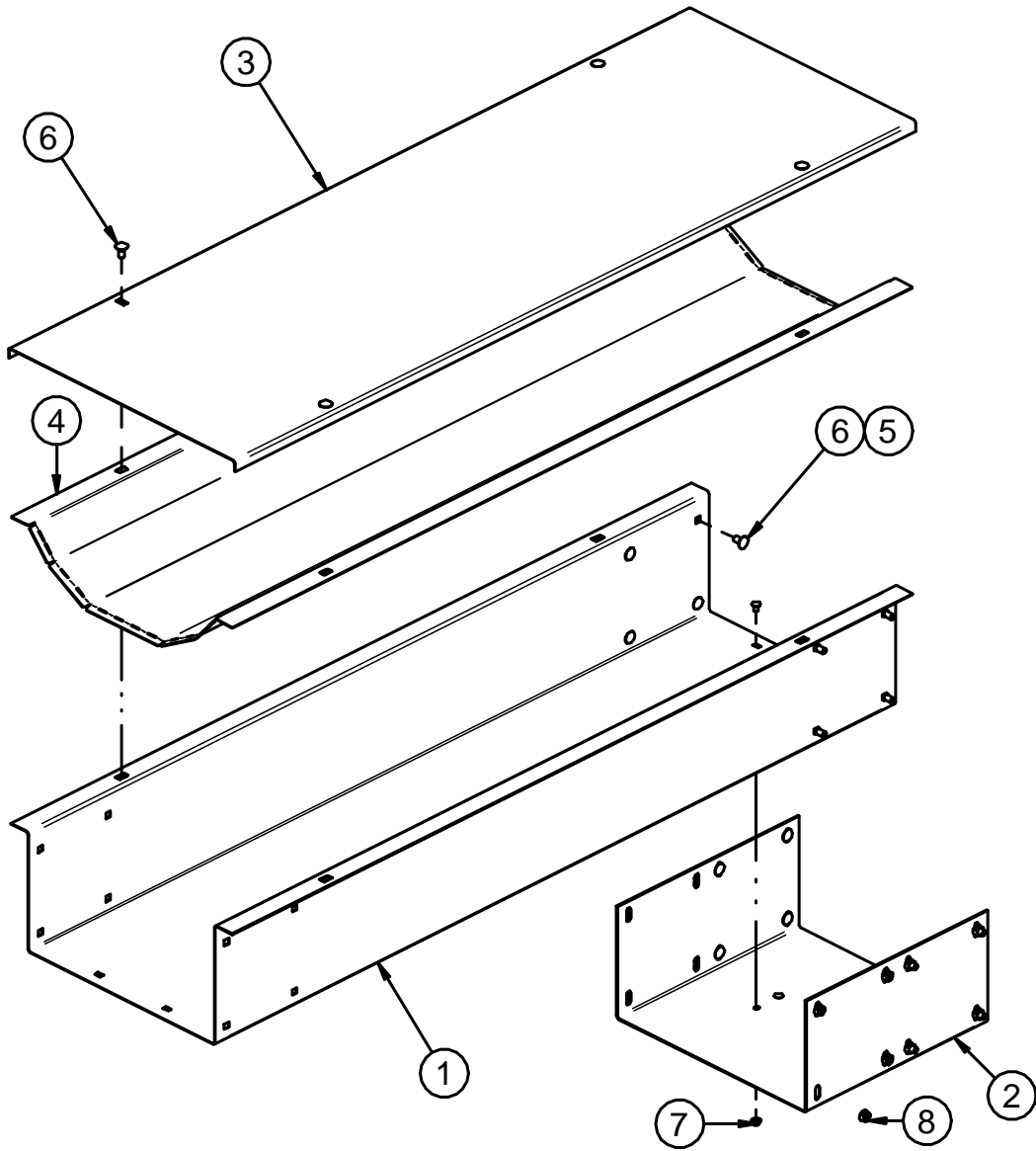

PART #		13-08-0866 REV A0	
Item #	Part #	Description	Qty
1	05-10-2931	FRM 5FT MID SECTION UB CNVR	1
2	05-10-2935	SPLICE PLATE-FORMED UB	1
3	05-10-2954	TOP COVER 5 FT SECTION UB	1
4	05-10-4648	TROUGH PAN 5FT SECT	1
5	06-01-0150	BOLT CRG .250-20 X .500 ZP	4
6	06-01-0153	BOLT CRG .375-16X.750 ZP SHORT NECK	20
7	06-03-0013	NUT LOCK FLG .250-20 ZP GR5	4
8	06-03-0014	NUT LOCK FLG .375-16 ZP GR5	20

UNDERBIN CONVEYOR

ASSEMBLY UB INTERMEDIATE 7.5FT WITH CLEANOUT (13-08-0769 REV A1)

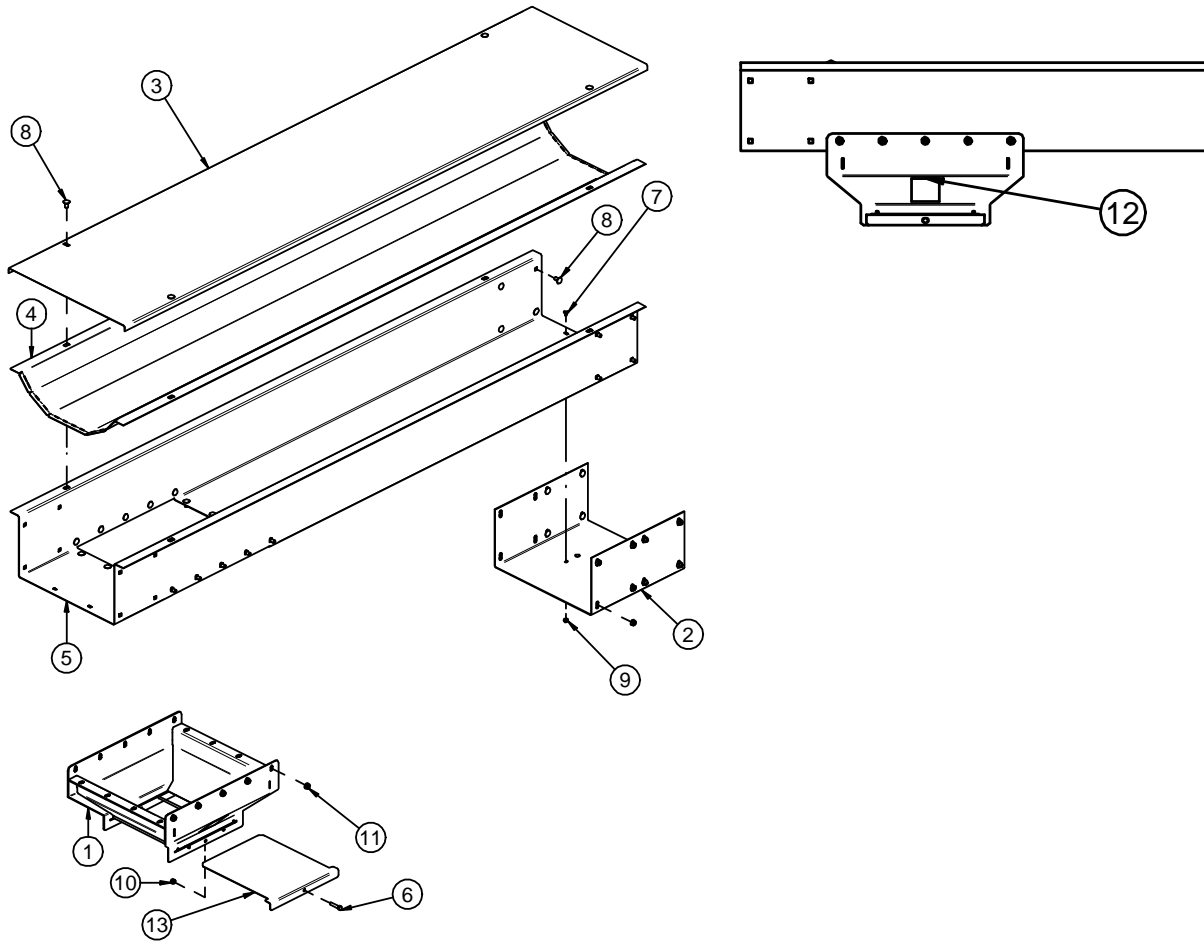

PART #		13-08-0769 REV A1	
Item #	Part #	Description	Qty
1	05-08-0742	WDMT CLEANOUT UB	1
2	05-10-2935	SPLICE PLATE-FORMED UB	1
3	05-10-2955	TOP COVER 7.5 FT SECTION UB	1
4	05-10-4649	TROUGH PAN 7.5FT SECT	1
5	05-10-4659	FRAME 7.5FT SECT UB W/CLNOUT	1
6	06-01-0013	BOLT .313-18 X 1.50 ZP GR5	1
7	06-01-0150	BOLT CRG .250-20 X .500 ZP	4
8	06-01-0153	BOLT CRG .375-16X.750 ZP SHORT NECK	38
9	06-03-0002	NUT NYL LOCK .313-18 ZP GR5	1
10	06-03-0013	NUT LOCK FLG .250-20 ZP GR5	4
11	06-03-0014	NUT LOCK FLG .375-16 ZP GR5	38
12	09-02-0011	ATWK LBL WARNING MOVING PART	2
13	105E0A	PLT SLIDE CLEANOUT UB	1

UNBERBIN CONVEYOR

ASSEMBLY UB INTERMEDIATE 10.FT (13-08-0770 REV A0)

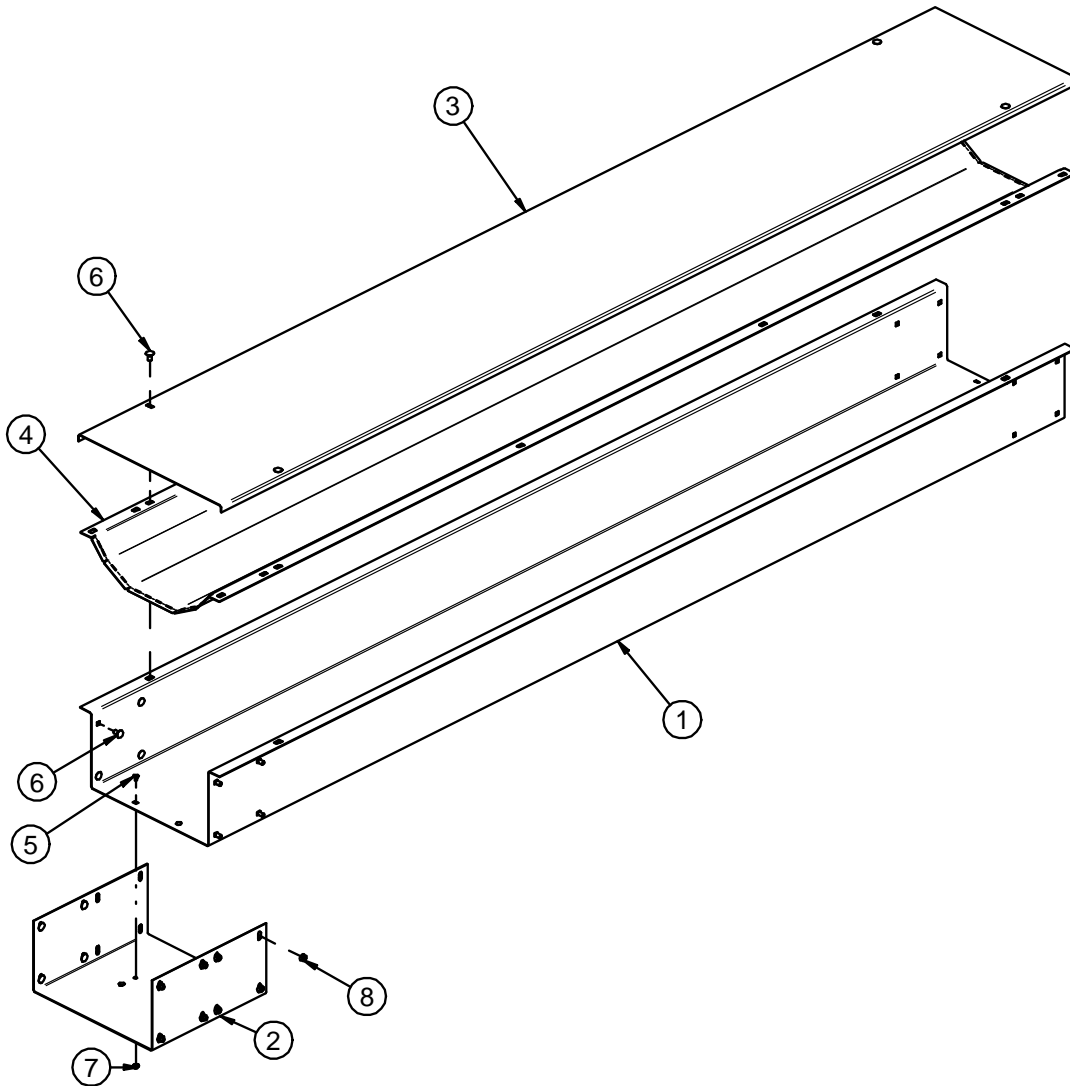

PART #		13-08-0770 REV A0	
Item #	Part #	Description	Qty
1	05-10-2916	FRM 10 FT MID SECTION UB CNVR	1
2	05-10-2935	SPLICE PLATE-FORMED UB	1
3	05-10-2956	TOP COVER 10FT SECTION UB	1
4	05-10-4650	TROUGH PAN 10FT SECT	1
5	06-01-0150	BOLT CRG .250-20 X .500 ZP	4
6	06-01-0153	BOLT CRG .375-16X.750 ZP SHORT NECK	20
7	06-03-0013	NUT LOCK FLG .250-20 ZP GR5	4
8	06-03-0014	NUT LOCK FLG .375-16 ZP GR5	20

UNDERBIN CONVEYOR

ASSEMBLY UB INTERMEDIATE 10.FT WITH CLEANOUT (13-08-0771 REV A1)

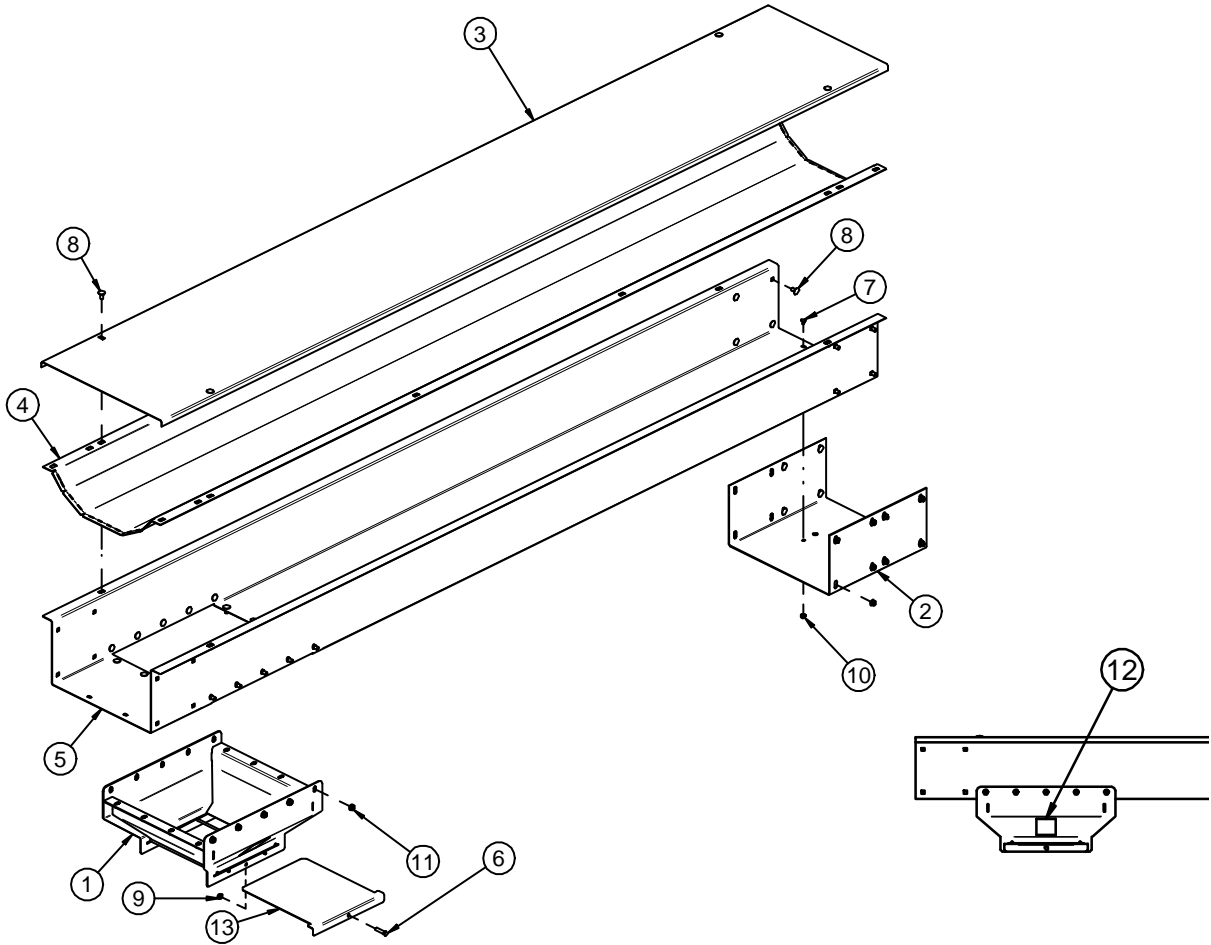

PART #		13-08-0771 REV A1	
Item #	Part #	Description	Qty
1	05-08-0742	WDMT CLEANOUT UB	1
2	05-10-2935	SPLICE PLATE-FORMED UB	1
3	05-10-2956	TOP COVER 10FT SECTION UB	1
4	05-10-4650	TROUGH PAN 10FT SECT	1
5	05-10-4660	FRAME 10FT SECT UB W/CLNOUT	1
6	06-01-0013	BOLT .313-18 X 1.50 ZP GR5	1
7	06-01-0150	BOLT CRG .250-20 X .500 ZP	4
8	06-01-0153	BOLT CRG .375-16X.750 ZP SHORT NECK	38
9	06-03-0002	NUT NYL LOCK .313-18 ZP GR5	1
10	06-03-0013	NUT LOCK FLG .250-20 ZP GR5	4
11	06-03-0014	NUT LOCK FLG .375-16 ZP GR5	38
12	09-02-0011	ATWK LBL WARNING MOVING PART	2
13	105E0A	PLT SLIDE CLEANOUT UB	1

UNBERBIN CONVEYOR

ASSEMBLY UB TAIL SECTION (13-08-0766 REV B0)

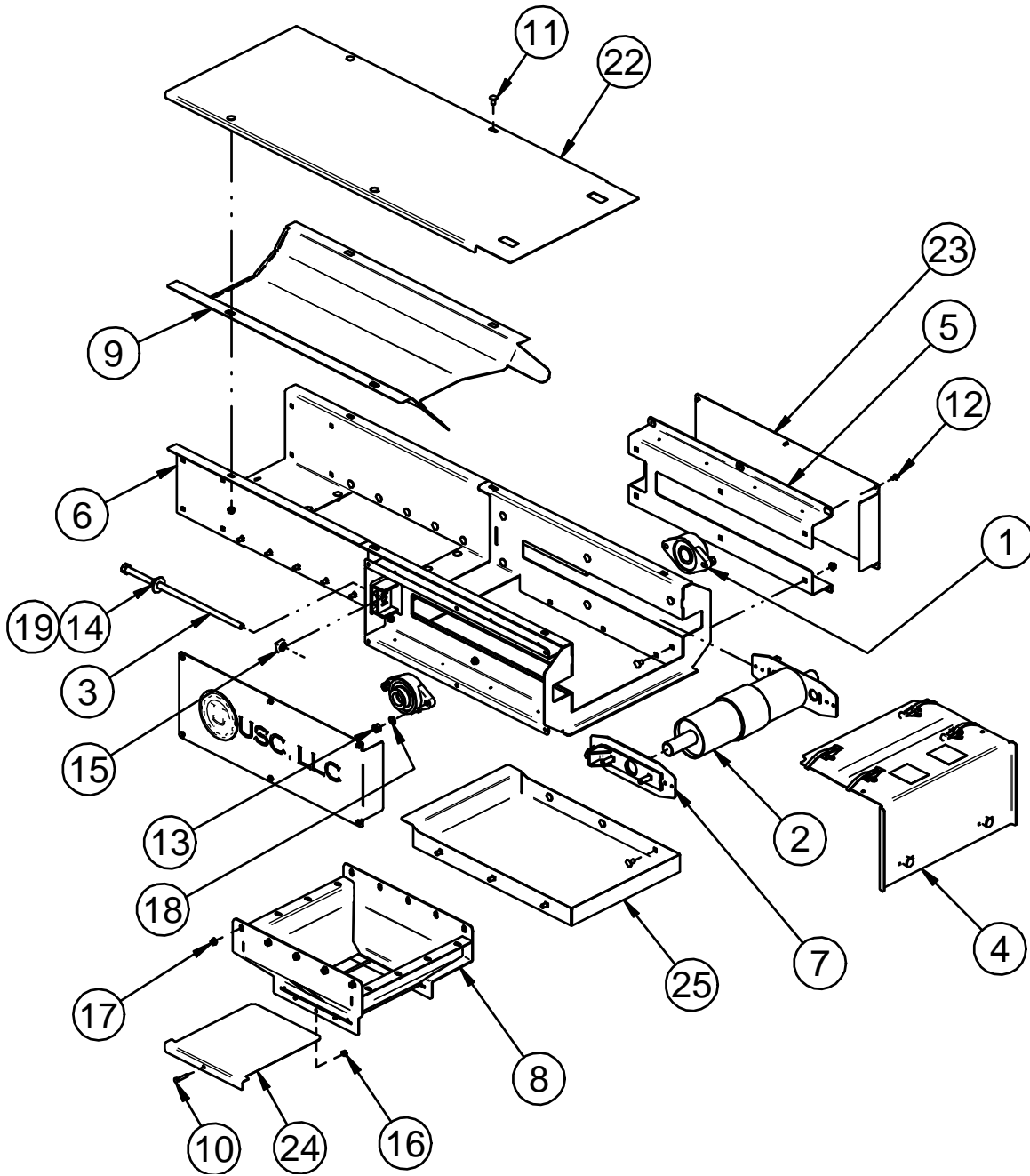

UNDERBIN CONVEYOR

ASSEMBLY UB TAIL SECTION (13-08-0766 REV B0)

PART #		13-08-0766 REV B0	
Item #	Part #	Description	Qty
1	01-03-0077	BRG FLG MNT 1.500ID 2BOLT ECNTRC	2
2	01-08-0144	PULLEY TAIL 4.50DIA X 15.50W LG BRG	1
3	05-03-1036	WDMT TNSNR BOLT TAIL UBC RVRS HD	2
4	05-06-0144	ASSY CLEANOUT CVR UB TAIL	1
5	05-08-0739	WDMT TAKE-UP COVER	2
6	05-08-0740	WDMT FRAME TAIL UB	1
7	05-08-0741	WDMT TAKE-UP PLT UB	2
8	05-08-0742	WDMT CLEANOUT UB	1
9	05-10-4847	PLT TRANS UB TAIL	1
10	06-01-0013	BOLT .313-18 X 1.50 ZP GR5	1
11	06-01-0153	BOLT CRG .375-16X.750 ZP SHORT NECK	40
12	06-01-0299	BOLT FLG .250-20 X .500 ZP GR5	12
13	06-02-0004	NUT FULL .500-13 ZP GR5	4
14	06-02-0005	NUT FULL .625-11 ZP GR5	2
15	06-02-0108	NUT SQUARE .625-11 ZP GR5	2
16	06-03-0002	NUT NYL LOCK .313-18 ZP GR5	1
17	06-03-0014	NUT LOCK FLG .375-16 ZP GR5	40
18	06-04-0004	WSHR LOCK SPLT .500 ZP	4
19	06-05-0006	WSHR FLAT .625 ZP	2
20	09-01-0043	ATWK LBL USC 22.00 X 5.75 PRO-CUT	2
21	09-02-0011	ATWK LBL WARNING MOVING PART	2
22	102171	PSM CVR 5FT TAIL UBC RVRS HD	1
23	105E08	COVER TAKE-UP	2
24	105E0A	PLT SLIDE CLEANOUT UB	1
25	105E0E	PAN TAIL UB	1

UNBERBIN CONVEYOR

ASSEMBLY UB REVERSE CHUTE (13-05-0682 REV A2)

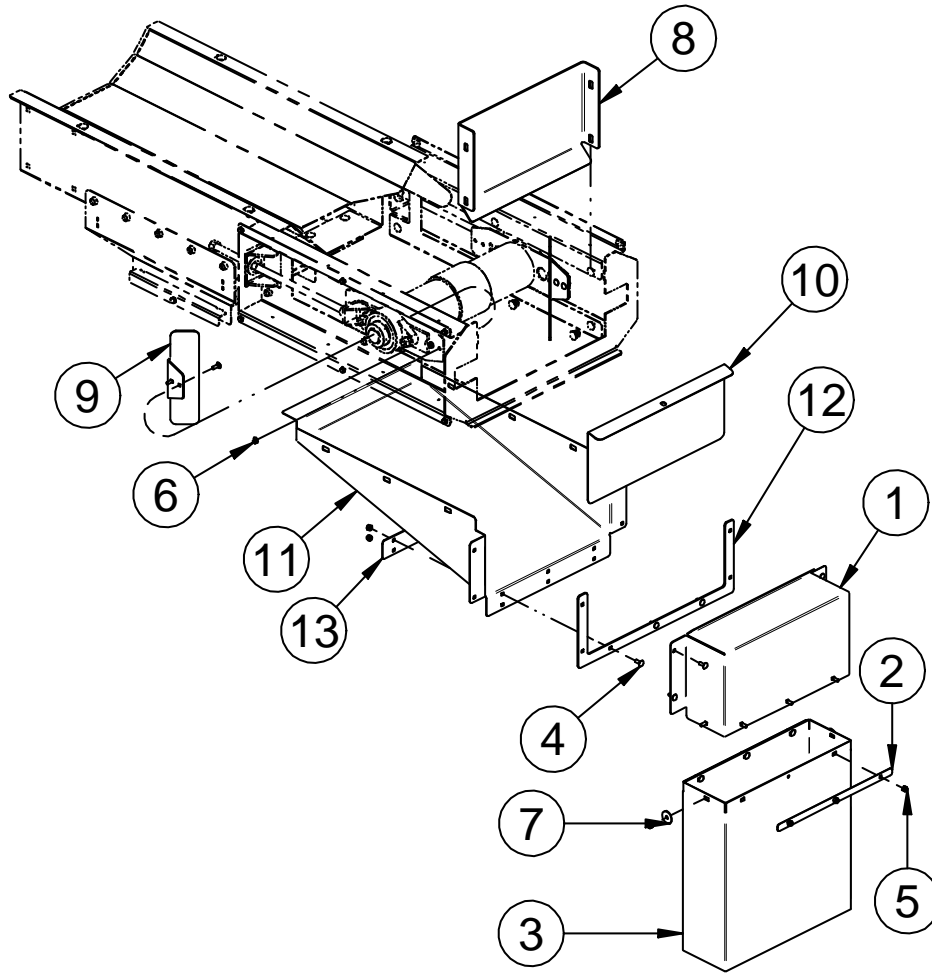

PART #		13-05-0682 REV A2	
Item #	Part #	Description	Qty
1	05-10-3560	PLT RVRS DSCH CHUTE 2	1
2	05-10-3563	PLT RVRS DSCH CHUTE CLMP	1
3	05-10-3564	PLT RVRS DSCH CHUTE EXT	1
4	06-01-0122	BOLT CRG .250-20 X .750 ZP GR5	19
5	06-03-0001	NUT NYL LOCK .250-20 ZP GR5	15
6	06-03-0013	NUT LOCK FLG .250-20 ZP GR5	4
7	06-05-0024	WSHR FNDR .250 ID 1.25 OD ZP	2
8	105E0B	PLT DEFLECTOR RVRS	1
9	105E0C	PLT SEED GUIDE RVRS	2
10	105E0D	PLT RVRS DSCHG CHUTE SLIDE	1
11	105E15	CHUTE UB TAIL RVRS	1
12	105E16	PLT SPACER	1
13	105E34	PLT CHUTE CLAMP	1

UNDERBIN CONVEYOR

ASSEMBLY DUAL UB DISCHARGE WITH CLEANOUT (13-08-0773 REV B0)

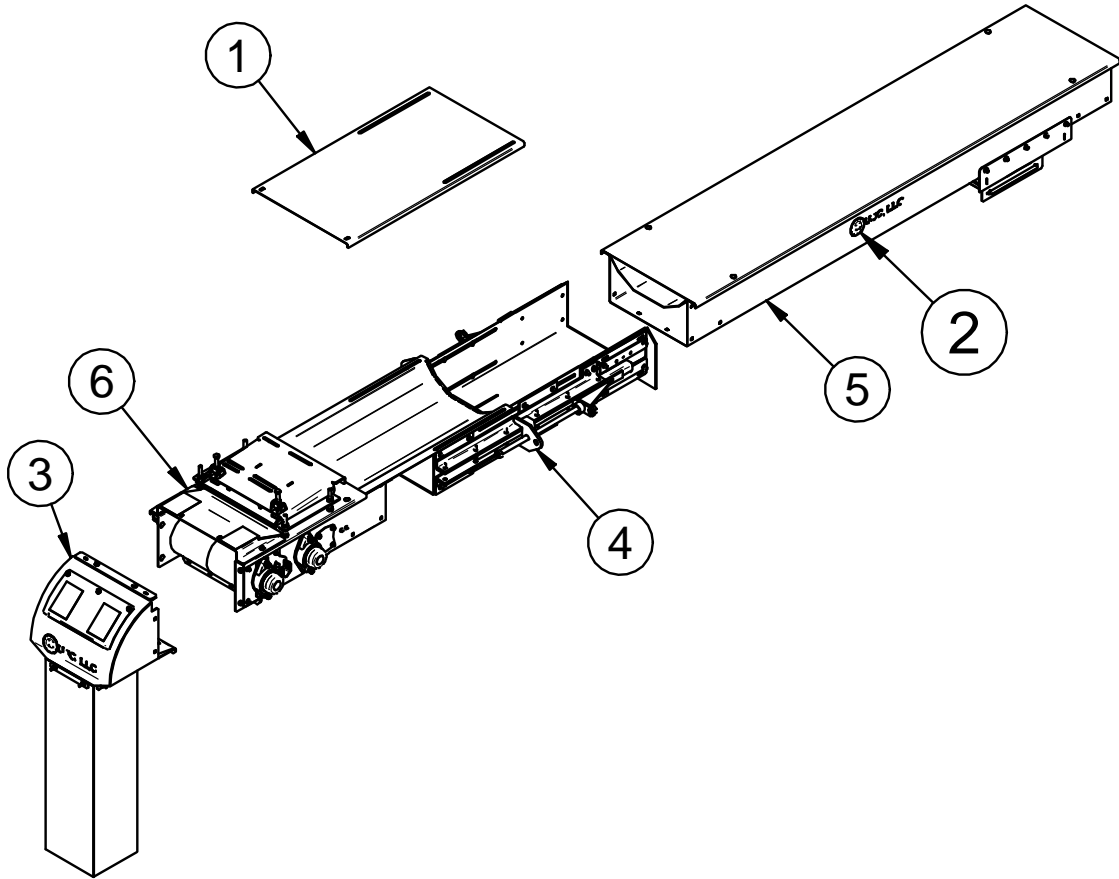

PART #		13-08-0773 REV B0		
Item #	Part #	Description	Qty	See Page
1	05-10-4643	COVER TOP UB DUAL DRV	1	
2	09-01-0042	ATWK LBL USC 11.50 X 3.00 PRO-CUT	2	
3	13-05-0674	ASSY UB HD	1	25
4	13-08-0462	ASSY DUAL UB TAKE-UP SPLICE	1	43
5	13-08-0774	ASSY UB INTER 7.5FT LESS SPLICE	1	45
6	13-08-0786	ASSY UB HD SECT LG BRG	1	39

UNBERBIN CONVEYOR

ASSEMBLY UB HEAD SECTION LARGE BEARING (13-08-0786 REV B0)

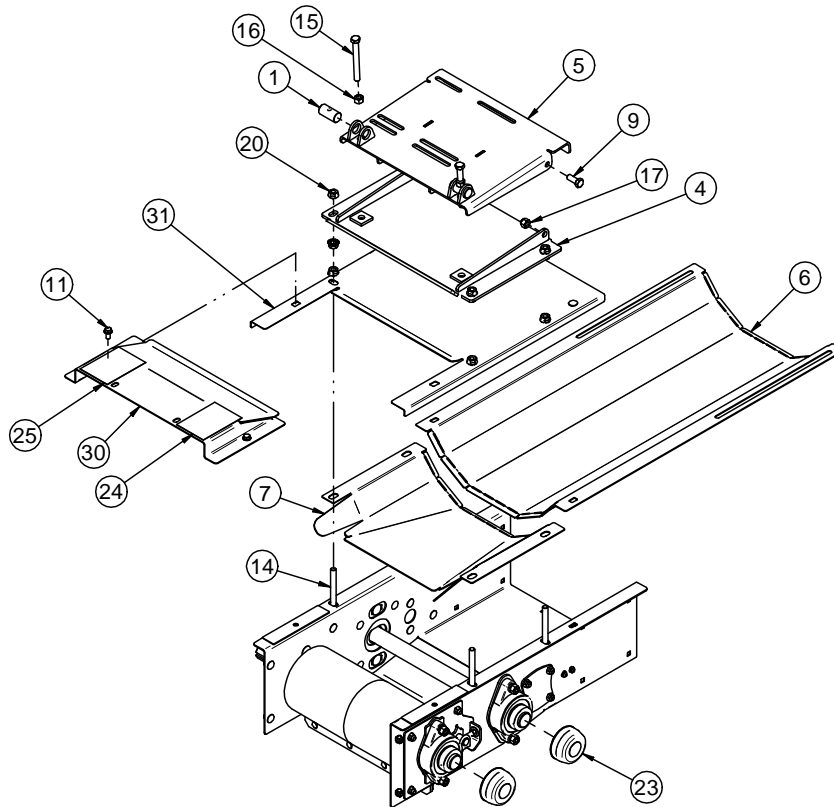
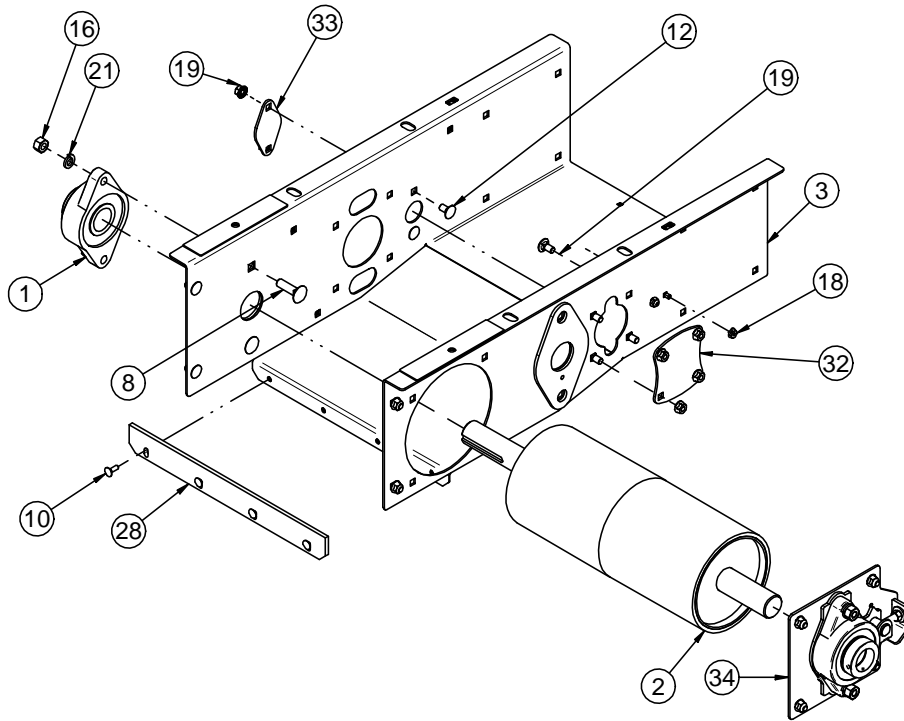

UNDERBIN CONVEYOR

ASSEMBLY UB HEAD SECTION LARGE BEARING (13-08-0786 REV B0)

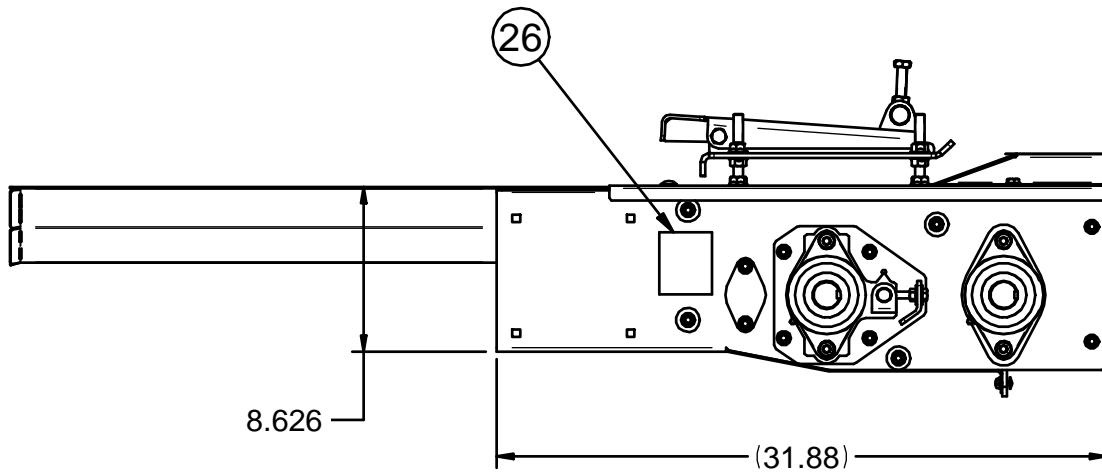
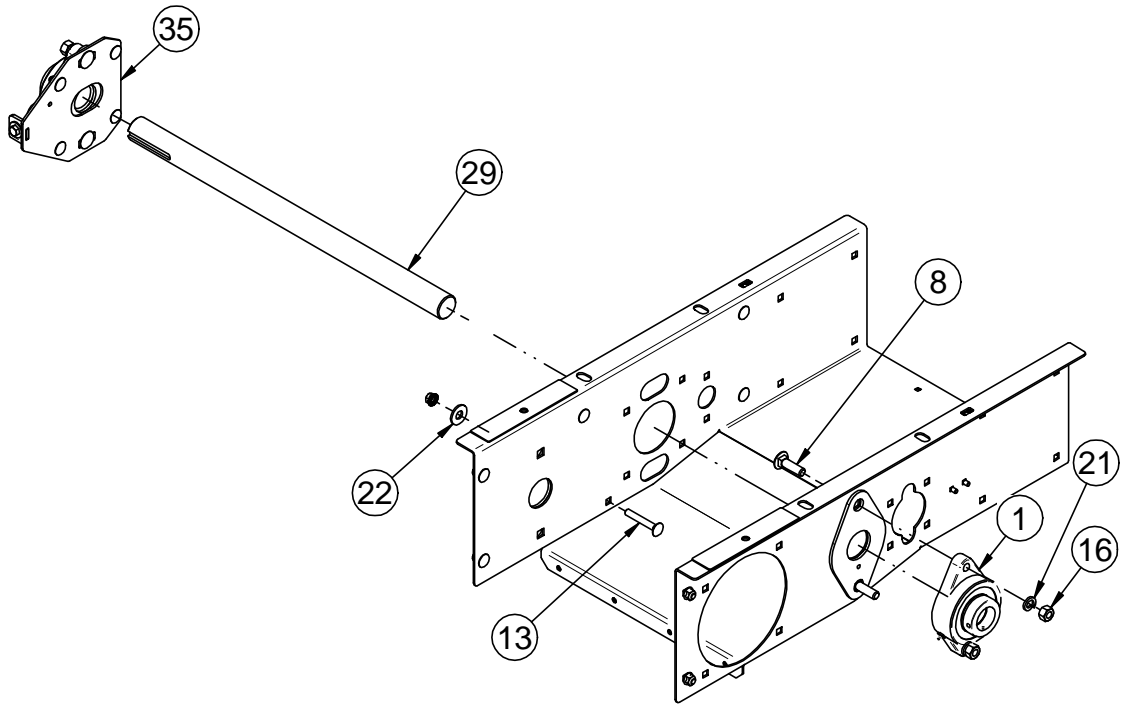

UNBERBIN CONVEYOR

ASSEMBLY UB HEAD SECTION LARGE BEARING (13-08-0786 REV B0)

PART #		13-08-0786 REV B0		
Item #	Part #	Description	Qty	See Page
1	01-03-0077	BRG FLG MNT 1.500ID 2BOLT ECNTRC	2	
2	01-08-0138	PULLEY HEAD 6.50 DIA X 15.50L 1.5IN	1	
3	05-08-0725	WDMT UB HD SECT	1	
4	05-08-0730	WDMT MTR BASE PLT	1	
5	05-08-0731	WDMT MTR MNT PLT UB	1	
6	05-10-5079	PLT TRANS UB REVERSE-1	1	
7	05-10-5080	PLT TRANS UB REVERSE-2	1	
8	06-01-0026	BOLT CRG .500-13 X 1.75 ZP GR5	4	
9	06-01-0080	BOLT .500-13 X 1.25 ZP GR5	2	
10	06-01-0122	BOLT CRG .250-20 X .750 ZP GR5	4	
11	06-01-0124	BOLT FLG .375-16 X .750 ZP GR5	2	
12	06-01-0153	BOLT CRG .375-16X.750 ZP SHORT NECK	12	
13	06-01-0154	BOLT CRG .375-16 X 2.50 ZP	4	
14	06-01-0157	BOLT .500-13 X 4.00 ZP GR5 FTH	4	
15	06-01-0221	BOLT .500-13 X 4.50 ZP GR5 FTH	2	
16	06-02-0004	NUT FULL .500-13 ZP GR5	6	
17	06-03-0004	NUT NYL LOCK .500-13 ZP GR5	2	
18	06-03-0013	NUT LOCK FLG .250-20 ZP GR5	6	
19	06-03-0014	NUT LOCK FLG .375-16 ZP GR5	16	
20	06-03-0015	NUT LOCK FLG .500-13 ZP GR5	12	
21	06-04-0004	WSHR LOCK SPLT .500 ZP	4	
22	06-05-0005	WSHR FLAT .500 ZP	4	
23	06-10-0080	CVR SNAP-ON 208 BRG	2	
24	09-02-0001	ATWK LBL DANGER FINGERS	1	
25	09-02-0002	ATWK LBL DANGER GRD	1	
26	09-02-0011	ATWK LBL WARNING MOVING PART	1	
27	10414A	PIN MTR PIVOT	2	
28	105C4C	RBBR SCRAPER UB	1	
29	105C4F	SHAFT 25.25 X 1.50" JACK-HEAD	1	
30	106447	COVER UB HD	1	
31	106448	COVER HD SECT UB	1	
32	1069DE	PLT BRG COVER	1	
33	1069DF	PLT SHAFT COVER	1	
34	13-08-0758	ASSY TRACKING PLT	1	21
35	13-08-0759	ASSY TRACKING PLT SM	1	22

UNDERBIN CONVEYOR

ASSEMBLY DUAL UB TAKE-UP SPLICE (13-08-0462 REV B2)

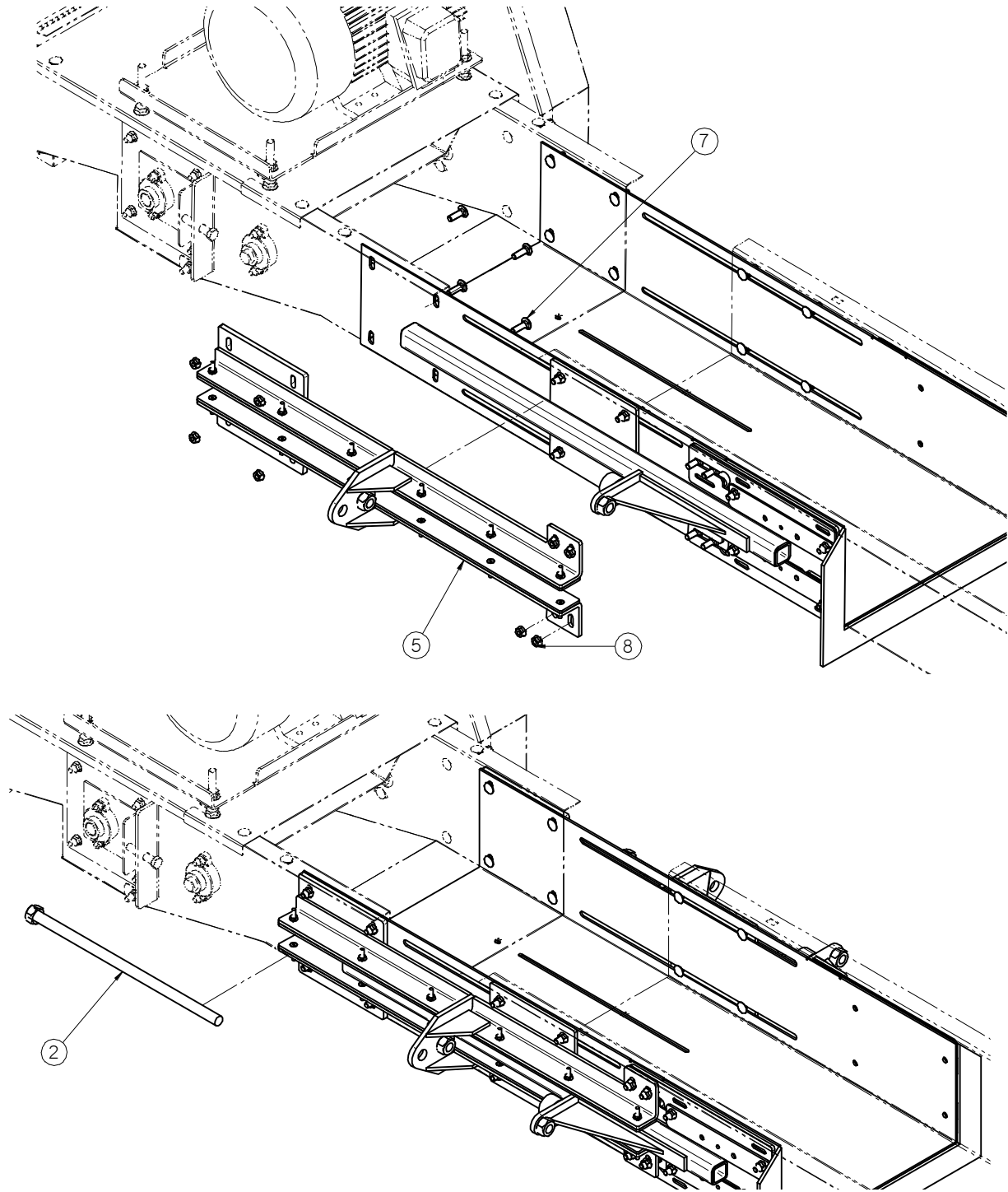

UNBERBIN CONVEYOR

ASSEMBLY DUAL UB TAKE-UP SPLICE (13-08-0462 REV B2)

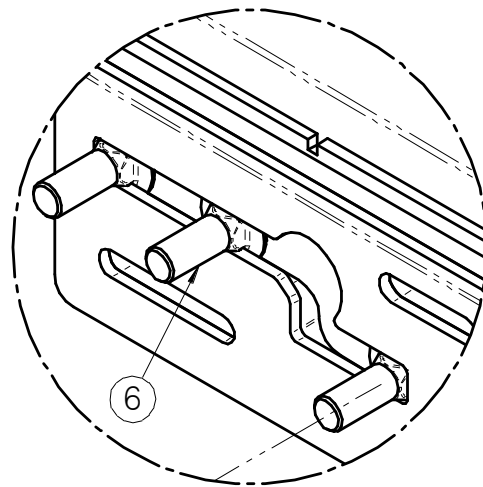
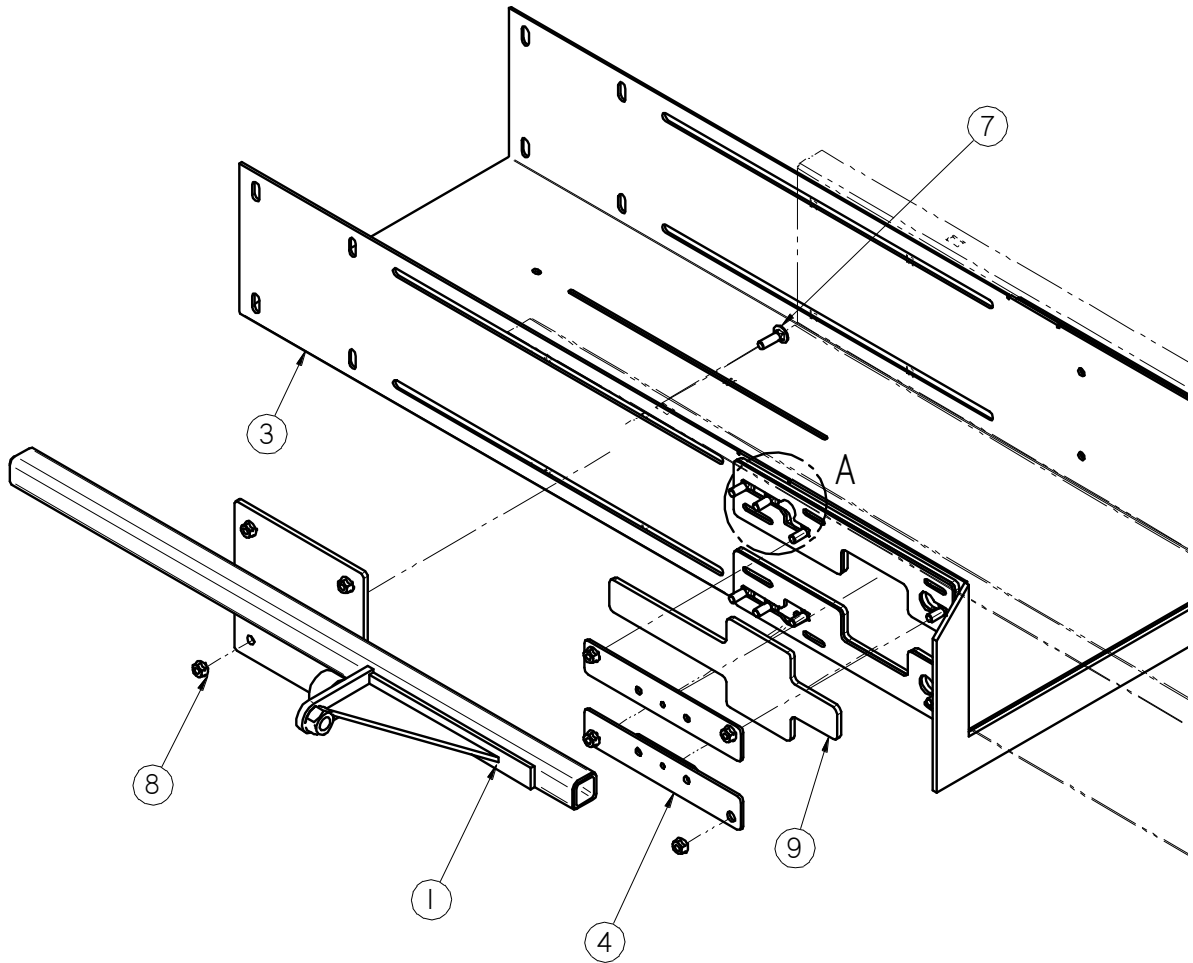

DETAIL A

UNDERBIN CONVEYOR

ASSEMBLY DUAL UB TAKE-UP SPLICE (13-08-0462 REV B2)

PART #		13-08-0462 REV B2	
Item #	Part #	Description	Qty
1	05-03-1492	WDMT TNSNR SLIDE	2
2	05-03-1501	WDMT TNSNR BOLT TAIL UBC .75 DIA	2
3	05-03-1662	WDMT DUAL UB SPLICE PAN	1
4	05-03-1663	WDMT CLAMP UB SPLICE	4
5	05-08-0401	ASSY SUPP RAIL	2
6	06-01-0115	BOLT CRG .375-16 X 1.00 ZP GR5	16
7	06-01-0127	BOLT CRG .375-16 X 1.25 ZP GR5	16
8	06-03-0014	NUT LOCK FLG .375-16 ZP GR5	32
9	104FB6	SKID PLATE	2

UNBERBIN CONVEYOR

ASSEMBLY UB INTERMEDIATE 7.5FT LESS SPLICE (13-08-0774 REV A1)

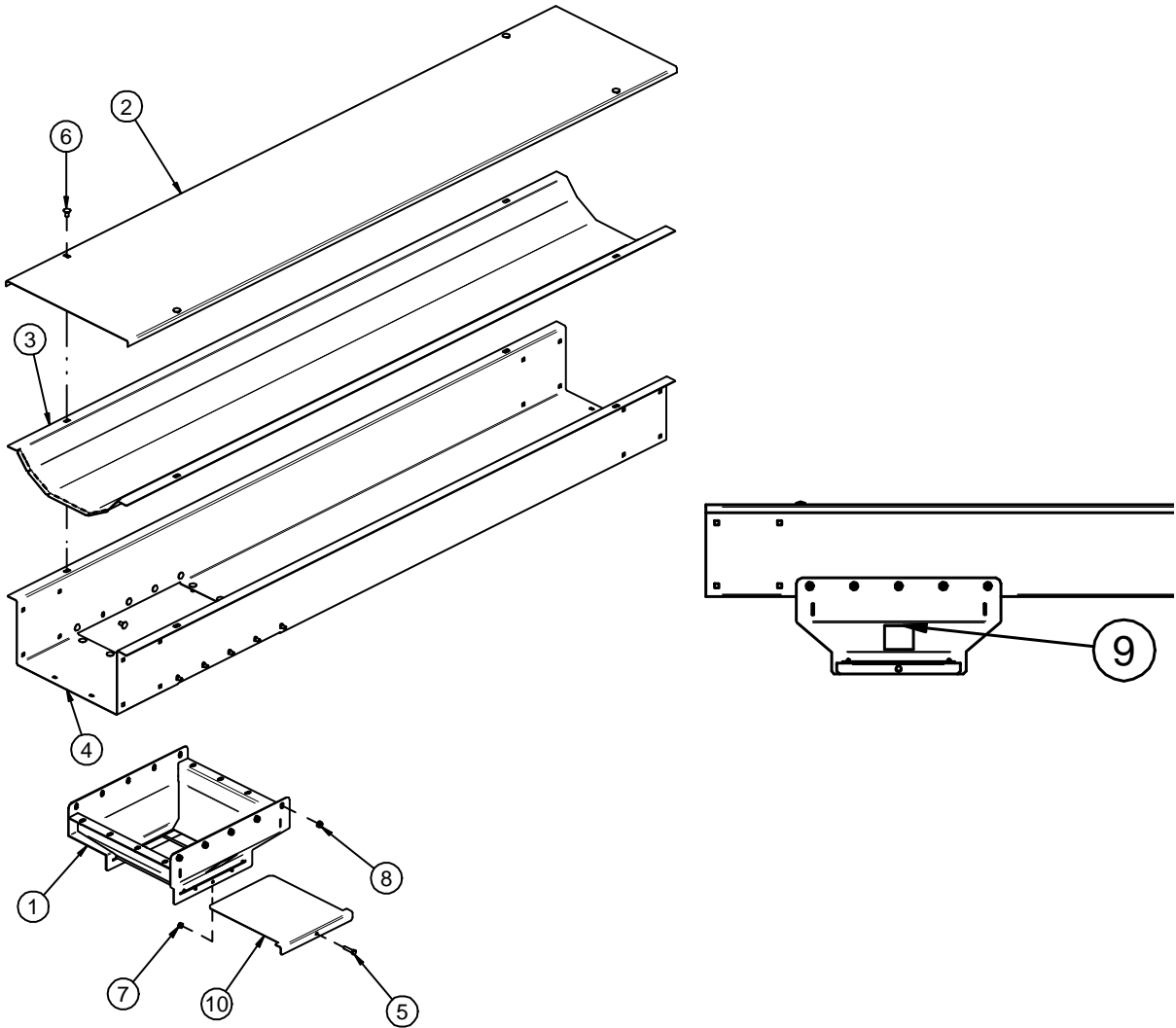

PART #		13-08-0774 REV A1	
Item #	Part #	Description	Qty
1	05-08-0742	WDMT CLEANOUT UB	1
2	05-10-2995	TOP COVER 7.5 FT SECTION UB	1
3	05-10-4652	TROUGH PAN DUAL HD SECT	1
4	05-10-4659	FRAME 7.5FT SECT UB W/CLNOUT	1
5	06-01-0013	BOLT .313-18 X 1.50 ZP GR5	1
6	06-01-0153	BOLT CRG .375-16X.750 ZP SHORT NECK	22
7	06-03-0002	NUT NYL LOCK .313-18 ZP GR5	1
8	06-03-0014	NUT LOCK FLG .375-16 ZP GR5	22
9	09-02-0011	ATWK LBL WARNING MOVING PART	2
10	105E0A	PLT SLIDE CLEANOUT UB	1

UNDERBIN CONVEYOR

UB BELTS

NOTE: Belt includes splice and pin.

CONVEYOR BELT LENGTHS					
CONVEYOR	BELT #	BELT	CONVEYOR	BELT #	BELT
15	11-02-0193	27.83	97.5	11-02-0226	192.83
17.5	11-02-0194	32.83	100	11-02-0227	197.83
20	11-02-0195	37.83	102.5	11-02-0228	202.83
22.5	11-02-0196	42.83	105	11-02-0229	207.83
25	11-02-0197	47.83	107.5	11-02-0230	212.83
27.5	11-02-0198	52.83	110	11-02-0231	217.83
30	11-02-0199	57.83	112.5	11-02-0232	222.83
32.5	11-02-0200	62.83	115	11-02-0233	227.83
35	11-02-0201	67.83	117.5	11-02-0234	232.83
37.5	11-02-0202	72.83	120	11-02-0235	237.83
40	11-02-0203	77.83	122.5	11-02-0236	242.83
42.5	11-02-0204	82.83	125	11-02-0237	245.17
45	11-02-0205	87.83	127.5	11-02-0238	250.17
47.5	11-02-0206	92.83	130	11-02-0239	255.17
50	11-02-0207	97.83	132.5	11-02-0240	260.17
52.5	11-02-0208	102.83	135	11-02-0241	265.17
55	11-02-0209	107.83	137.5	11-02-0242	270.17
57.5	11-02-0210	112.83	140	11-02-0243	275.17
60	11-02-0211	117.83	142.5	11-02-0244	280.17
62.5	11-02-0212	122.83	145	11-02-0245	285.17
65	11-02-0213	127.83	147.5	11-02-0246	290.17
67.5	11-02-0214	132.83	150	11-02-0247	295.17
70	11-02-0215	137.83	152.5	11-02-0248	300.17
72.5	11-02-0216	142.83	155	11-02-0249	305.17
75	11-02-0217	147.83	157.5	11-02-0250	310.17
77.5	11-02-0218	152.83	160	11-02-0251	315.17
80	11-02-0219	157.83	162.5	11-02-0252	320.17
82.5	11-02-0220	162.83	165	11-02-0253	325.17
85	11-02-0221	167.83	167.5	11-02-0254	330.17
87.5	11-02-0222	172.83	170	11-02-0255	335.17
90	11-02-0223	177.83	172.5	11-02-0256	340.17
92.5	11-02-0224	182.83	175	11-02-0257	345.17
95	11-02-0225	187.83			

UNBERBIN CONVEYOR
KIT UB CONVEYOR LEGS (05-05-0007 REV C0)

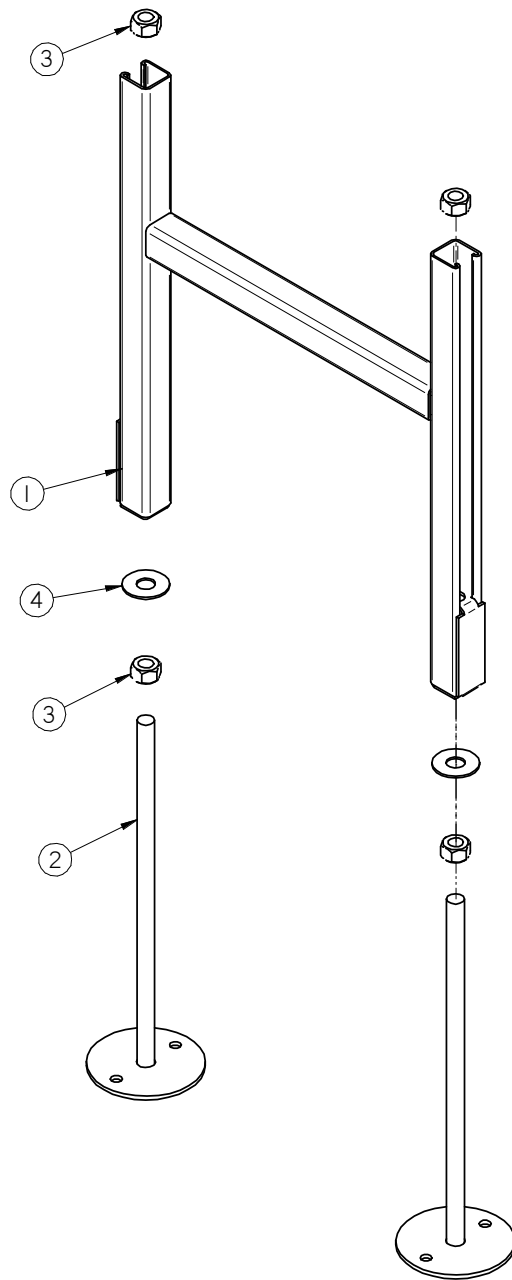

PART #		05-05-0007 REV C0	
Item #	Part #	Description	Qty
1	05-05-0008	WDMT UB CNVR LEGS TOP	1
2	05-05-0009	WDMT UB CNVR LEGS BTTM	2
3	06-02-0006	NUT FULL .750-10 ZP GR5	4
4	06-05-0007	WSHR FLAT .750 ZP	2

UNDERBIN CONVEYOR

KIT UB CONVEYOR LEGS EXTENDED 16 IN (05-05-0044 REV A1)

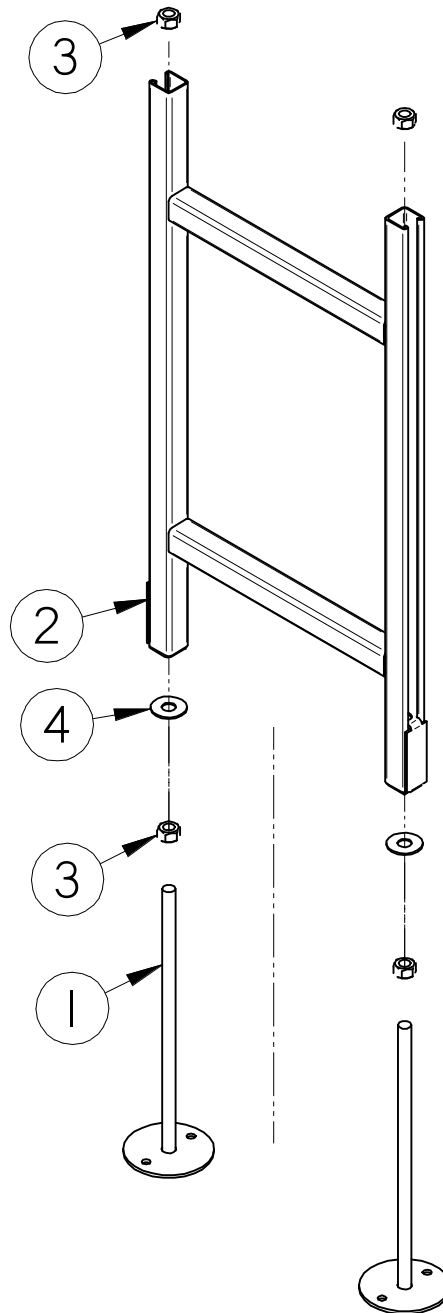

PART #		05-05-0044 REV A1	
Item #	Part #	Description	Qty
1	05-05-0009	WDMT UB CNVR LEGS BTTM	2
2	05-05-0045	UB CNVR LEGS TOP WDMT EXTD 16IN	1
3	06-02-0006	NUT FULL .750-10 ZP GR5	4
4	06-05-0007	WSHR FLAT .750 ZP	2

UNBERBIN CONVEYOR

ASSEMBLY UB CONVEYOR HANGER LONG (05-05-0112 REV B0)

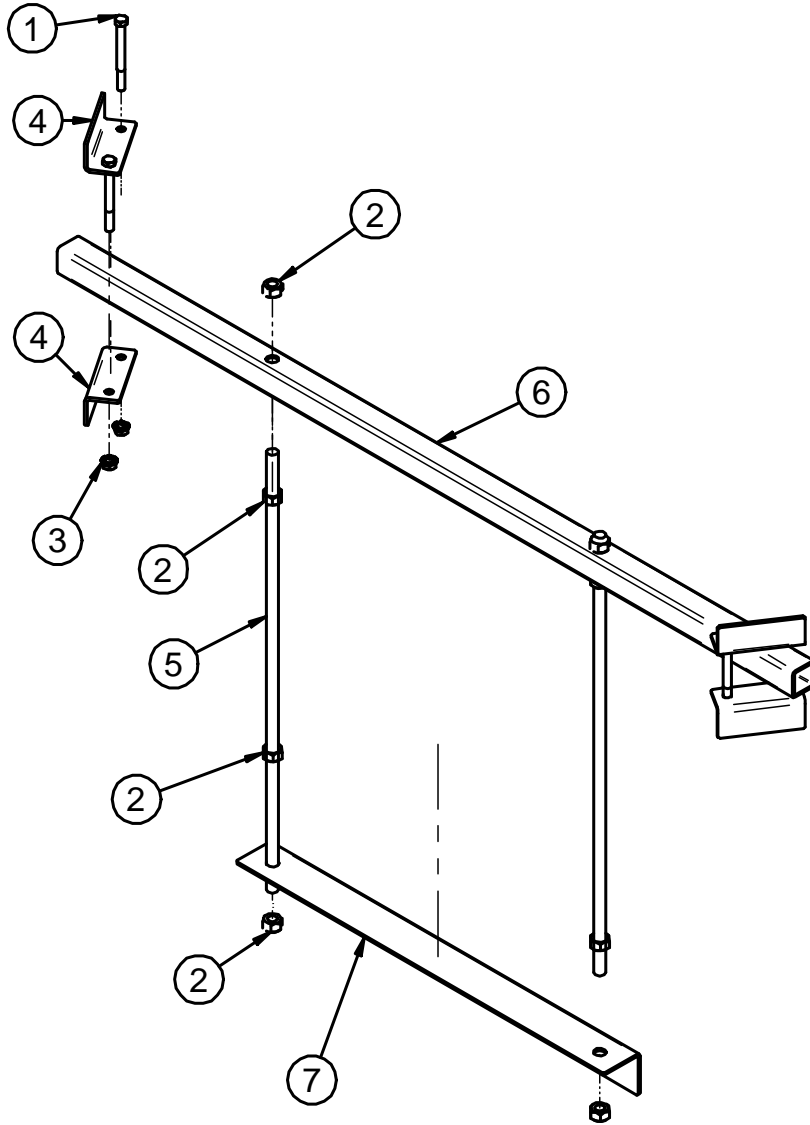

PART #		05-05-0044 REV B0	
Item #	Part #	Description	Qty
1	06-01-0119	BOLT .500-13 X 5.00 ZP GR5	4
2	06-02-0006	NUT FULL .750-10 ZP GR5	8
3	06-03-0015	NUT LOCK FLG .500-13 ZP GR5	4
4	1035A4	ANGLE UB SHORT	4
5	1035A6	ROD UB HANGER	2
6	105B61	TUBE UB HANGER LG	1
7	105B62	ANGLE UB LONG	1

UNDERBIN CONVEYOR

ASSEMBLY UB HOPPER MERIDIAN 8 INCH (13-05-0293 REV B4)

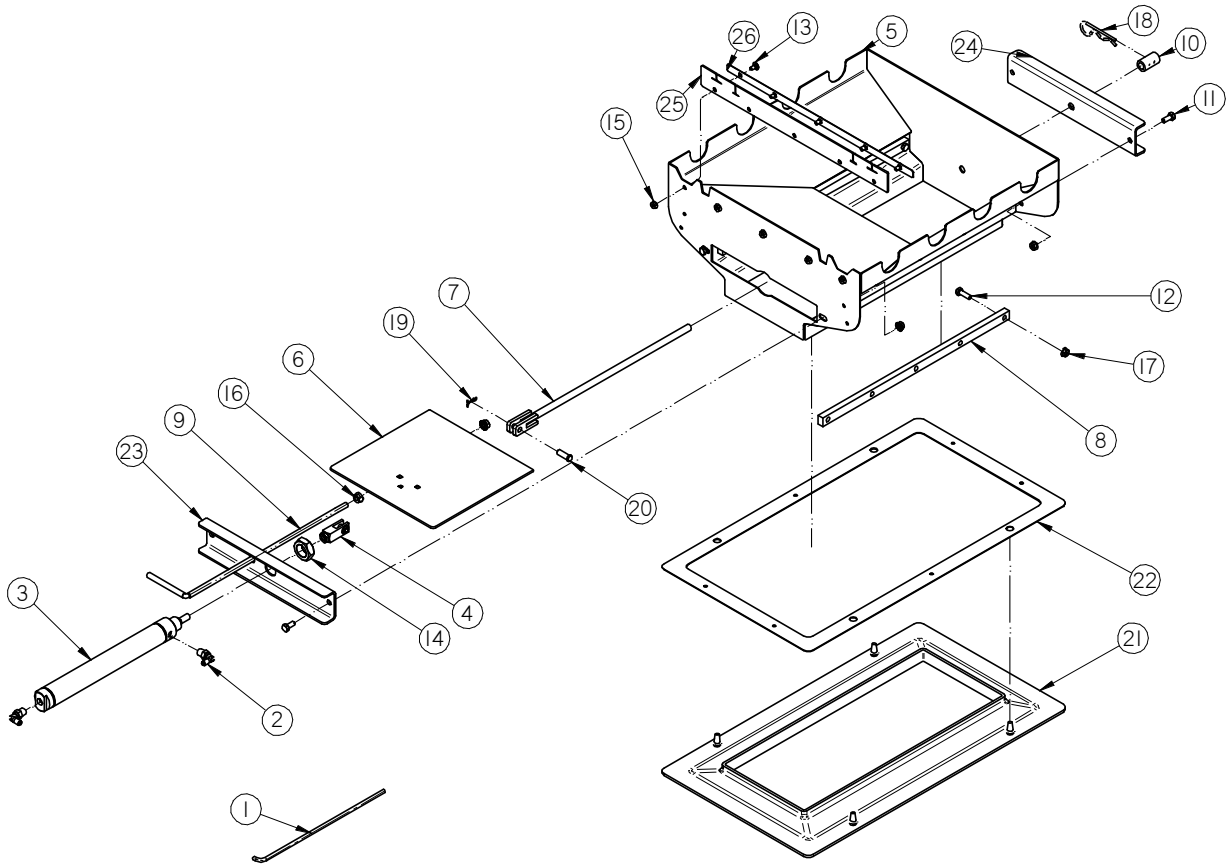

UNBERBIN CONVEYOR

ASSEMBLY UB HOPPER MERIDIAN 8 INCH (13-05-0293 REV B4)

PART #		13-05-0293 REV B4	
Item #	Part #	Description	Qty
1	02-03-0051	TBG .250 OD NYL BLK	1.333
2	02-16-0044	FTTG PUSH 90 DEG .250OD X .250 NPT	2
3	03-17-0045	BIMBA CYL 10" ST 1.5 BR MRS-1710-DB	1
4	03-17-0046	CLEVIS ASSY BIMBA D-8311-A	1
5	05-03-1370	WDMT UB HOPP MERIDIAN 8IN	1
6	05-03-1404	WDMT UB HOPPER SLIDE 8IN	1
7	05-04-0078	WDMT SLGT STOP ROD	1
8	05-10-3103	PLT UB HOPP SLIDE BEARING	2
9	05-11-0197	UB HOPP SLIDE ROD	1
10	05-11-0268	SLV SLIDE GATE ADJ STOP	1
11	06-01-0010	BOLT .313-18 X .750 ZP GR5	4
12	06-01-0012	BOLT .313-18 X 1.00 ZP GR5	10
13	06-01-0150	BOLT CRG .250-20 X .500 ZP	5
14	06-02-0067	NUT BIMBA D-1331	1
15	06-03-0013	NUT LOCK FLG .250-20 ZP GR5	5
16	06-03-0014	NUT LOCK FLG .375-16 ZP GR5	2
17	06-03-0019	NUT LOCK FLG .313-18 ZP GR5	14
18	06-09-0002	PIN CLIP HITCH 3.063 SIZE 9 ZP	1
19	06-09-0013	PIN CTR .125 X .75 ZP	1
20	06-09-0059	PIN CLVS .375 X 1.125 PLN	1
21	06-10-0048	SEAL RBBR SL GATE UB	1
22	102ECC	PLT UB HOPP SEAL	1
23	103247	PLT UB HOPP CYL MT	1
24	103248	PLT UB HOPP MT	1
25	105B4D	SEAL GATE	1
26	105B5F	PLT SEAL BACKING	1
27	13-10-0008	KIT INSTALL UB HOPP	1

UNDERBIN CONVEYOR

ASSEMBLY UB HOPPER SCHULD BUSHNELL 8 INCH (13-05-0294 REV A4)

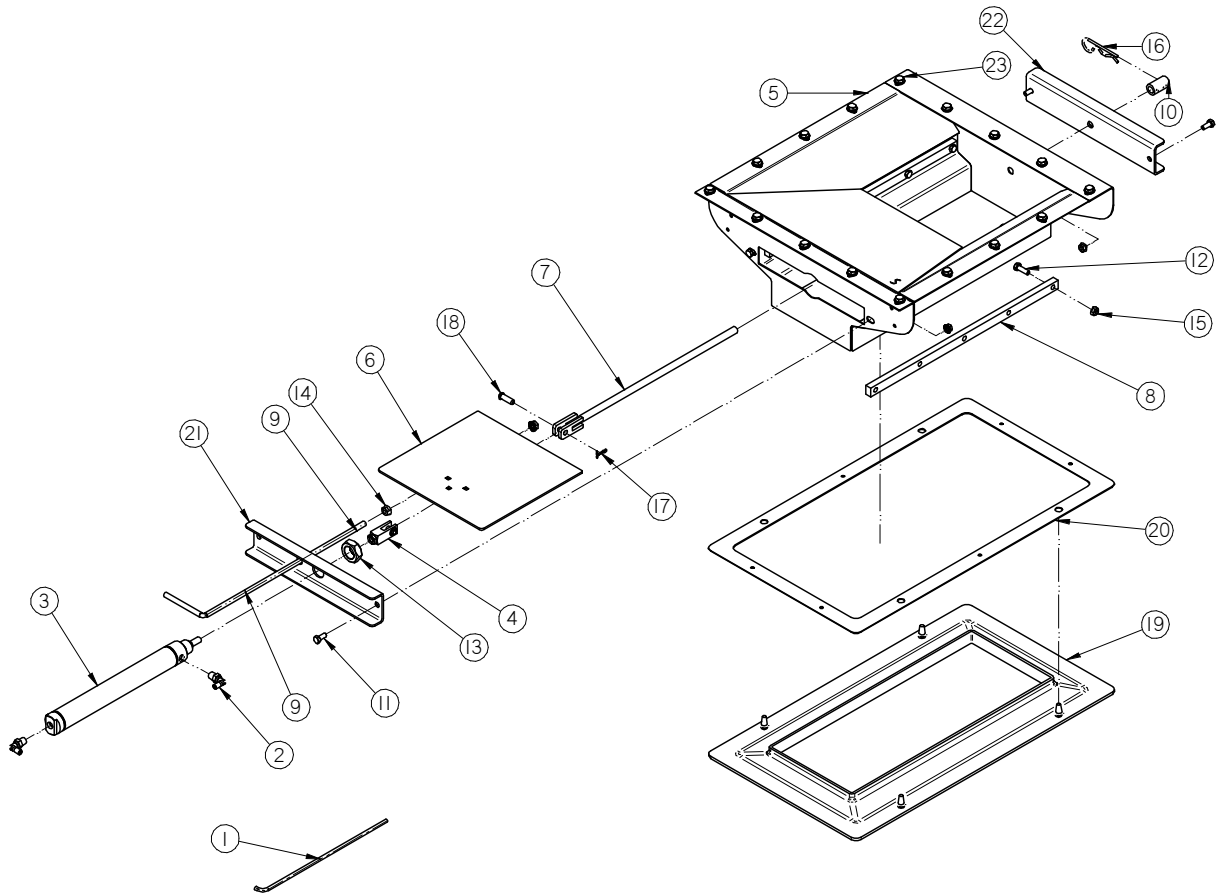

UNBERBIN CONVEYOR

ASSEMBLY UB HOPPER SCHULD BUSHNELL 8 INCH (13-05-0294 REV A4)

PART #		13-05-0294 REV A4	
Item #	Part #	Description	Qty
1	02-03-0051	TBG .250 OD NYL BLK	1.333
2	02-16-0044	FTTG PUSH 90 DEG .250OD X .250 NPT	2
3	03-17-0045	BIMBA CYL 10" ST 1.5 BR MRS-1710-DB	1
4	03-17-0046	CLEVIS ASSY BIMBA D-8311-A	1
5	05-03-1371	WDMT UB HOPP SCH-BUSH 8IN	1
6	05-03-1404	WDMT UB HOPPER SLIDE 8IN	1
7	05-04-0078	WDMT SLGT STOP ROD	1
8	05-10-3103	PLT UB HOPP SLIDE BEARING	2
9	05-11-0197	UB HOPP SLIDE ROD	1
10	05-11-0268	SLV SLIDE GATE ADJ STOP	1
11	06-01-0010	BOLT .313-18 X .750 ZP GR5	4
12	06-01-0012	BOLT .313-18 X 1.00 ZP GR5	10
13	06-02-0067	NUT BIMBA D-1331	1
14	06-03-0014	NUT LOCK FLG .375-16 ZP GR5	2
15	06-03-0019	NUT LOCK FLG .313-18 ZP GR5	14
16	06-09-0002	PIN CLIP HITCH 3.063 SIZE 9 ZP	1
17	06-09-0013	PIN CTTR .125 X .75 ZP	1
18	06-09-0059	PIN CLVS .375 X 1.125 PLN	1
19	06-10-0048	SEAL RBBR SL GATE UB	1
20	102ECC	PLT UB HOPP SEAL	1
21	103247	PLT UB HOPP CYL MT	1
22	103248	PLT UB HOPP MT	1
23	13-10-0007	KIT INSTALL UB HOPP SCHULD-BUSHNELL	1

UNDERBIN CONVEYOR

ASSEMBLY UB HOPPER YORK 8 INCH (13-05-0295 REV A4)

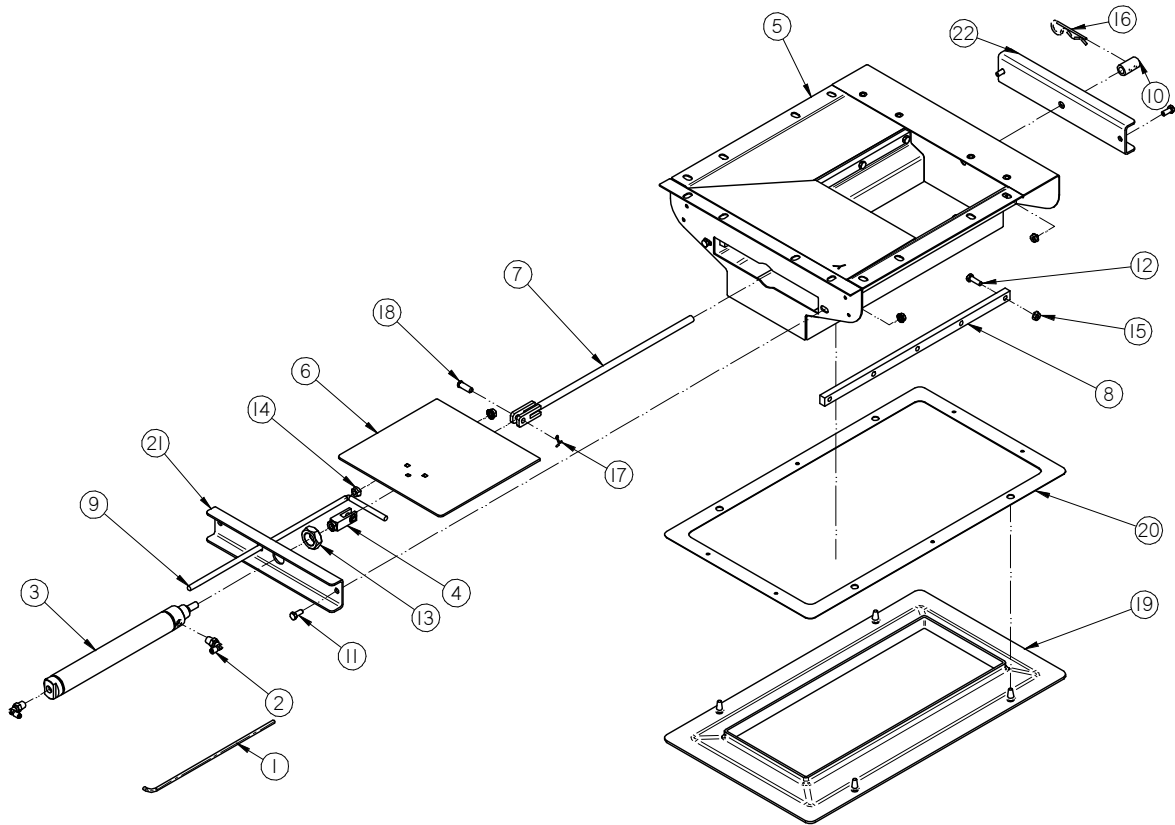

UNBERBIN CONVEYOR

ASSEMBLY UB HOPPER YORK 8 INCH (13-05-0295 REV A4)

PART #		13-05-0295 REV A4	
Item #	Part #	Description	Qty
1	02-03-0051	TBG .250 OD NYL BLK	1.333
2	02-16-0044	FTTG PUSH 90 DEG .250OD X .250 NPT	2
3	03-17-0045	BIMBA CYL 10" ST 1.5 BR MRS-1710-DB	1
4	03-17-0046	CLEVIS ASSY BIMBA D-8311-A	1
5	05-03-1372	WDMT UB HOPP YORK 8IN	1
6	05-03-1404	WDMT UB HOPPER SLIDE 8IN	1
7	05-04-0078	WDMT SLGT STOP ROD	1
8	05-10-3103	PLT UB HOPP SLIDE BEARING	2
9	05-11-0197	UB HOPP SLIDE ROD	1
10	05-11-0268	SLV SLIDE GATE ADJ STOP	1
11	06-01-0010	BOLT .313-18 X .750 ZP GR5	4
12	06-01-0012	BOLT .313-18 X 1.00 ZP GR5	10
13	06-02-0067	NUT BIMBA D-1331	1
14	06-03-0014	NUT LOCK FLG .375-16 ZP GR5	2
15	06-03-0019	NUT LOCK FLG .313-18 ZP GR5	14
16	06-09-0002	PIN CLIP HITCH 3.063 SIZE 9 ZP	1
17	06-09-0013	PIN CTTR .125 X .75 ZP	1
18	06-09-0059	PIN CLVS .375 X 1.125 PLN	1
19	06-10-0048	SEAL RBBR SL GATE UB	1
20	102ECC	PLT UB HOPP SEAL	1
21	103247	PLT UB HOPP CYL MT	1
22	103248	PLT UB HOPP MT	1
23	13-10-0007	KIT INSTALL UB HOPP SCHULD-BUSHNELL	1

UNDERBIN CONVEYOR

ASSEMBLY UB HOPPER WESTEEL 8 INCH (13-05-0296 REV A4)

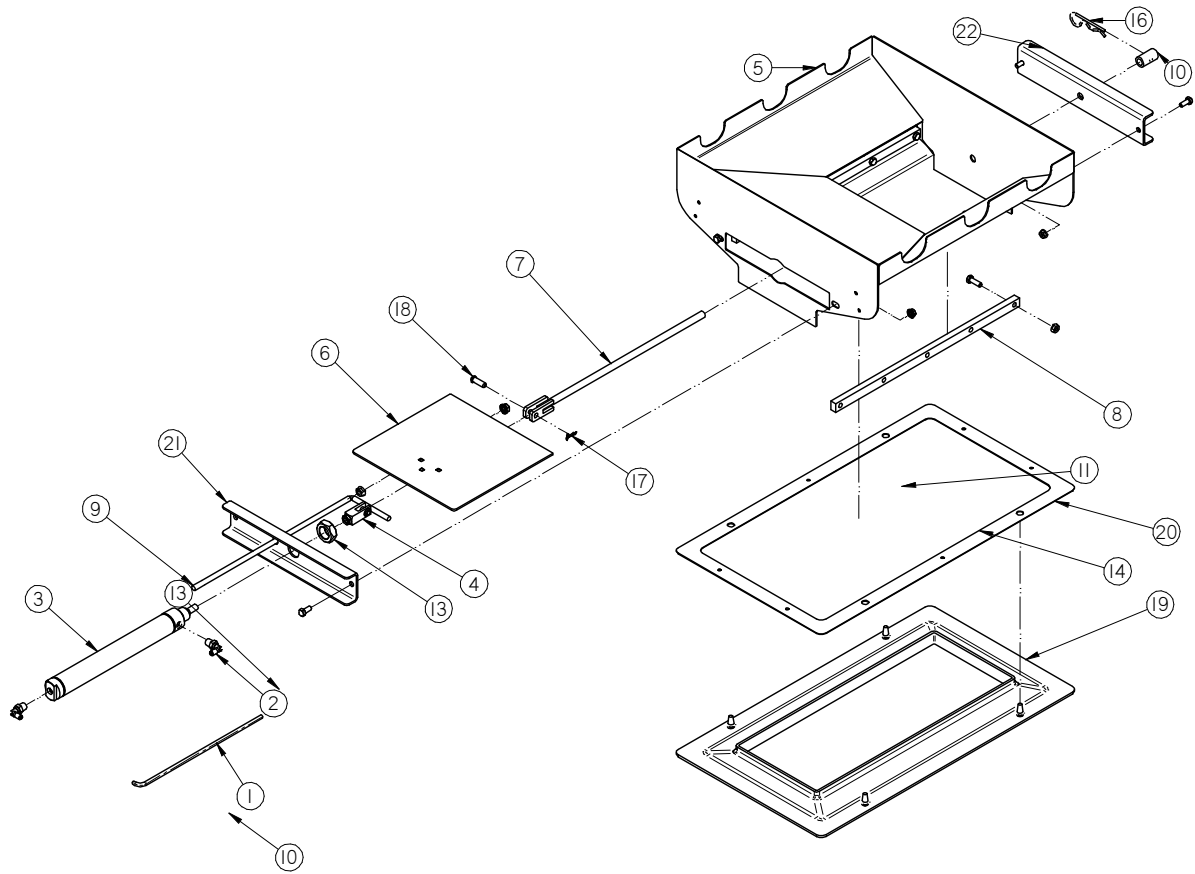

UNBERBIN CONVEYOR

ASSEMBLY UB HOPPER WESTEEL 8 INCH (13-05-0296 REV A4)

PART #		13-05-0296 REV A4	
Item #	Part #	Description	Qty
1	02-03-0051	TBG .250 OD NYL BLK	1.333
2	02-16-0044	FTTG PUSH 90 DEG .250OD X .250 NPT	2
3	03-17-0045	BIMBA CYL 10" ST 1.5 BR MRS-1710-DB	1
4	03-17-0046	CLEVIS ASSY BIMBA D-8311-A	1
5	05-03-1373	WDMT UB HOPP WESTEEL 8IN	1
6	05-03-1404	WDMT UB HOPPER SLIDE 8IN	1
7	05-04-0078	WDMT SLGT STOP ROD	1
8	05-10-3103	PLT UB HOPP SLIDE BEARING	2
9	05-11-0197	UB HOPP SLIDE ROD	1
10	05-11-0268	SLV SLIDE GATE ADJ STOP	1
11	06-01-0010	BOLT .313-18 X .750 ZP GR5	4
12	06-01-0012	BOLT .313-18 X 1.00 ZP GR5	10
13	06-02-0067	NUT BIMBA D-1331	1
14	06-03-0014	NUT LOCK FLG .375-16 ZP GR5	2
15	06-03-0019	NUT LOCK FLG .313-18 ZP GR5	14
16	06-09-0002	PIN CLIP HITCH 3.063 SIZE 9 ZP	1
17	06-09-0013	PIN CTRR .125 X .75 ZP	1
18	06-09-0059	PIN CLVS .375 X 1.125 PLN	1
19	06-10-0048	SEAL RBBR SL GATE UB	1
20	102ECC	PLT UB HOPP SEAL	1
21	103247	PLT UB HOPP CYL MT	1
22	103248	PLT UB HOPP MT	1
23	13-10-0008	KIT INSTALL UB HOPP	1

UNDERBIN CONVEYOR

ASSEMBLY UB HOPPER AMBER WAVES 8 INCH (13-05-0307 REV A3)

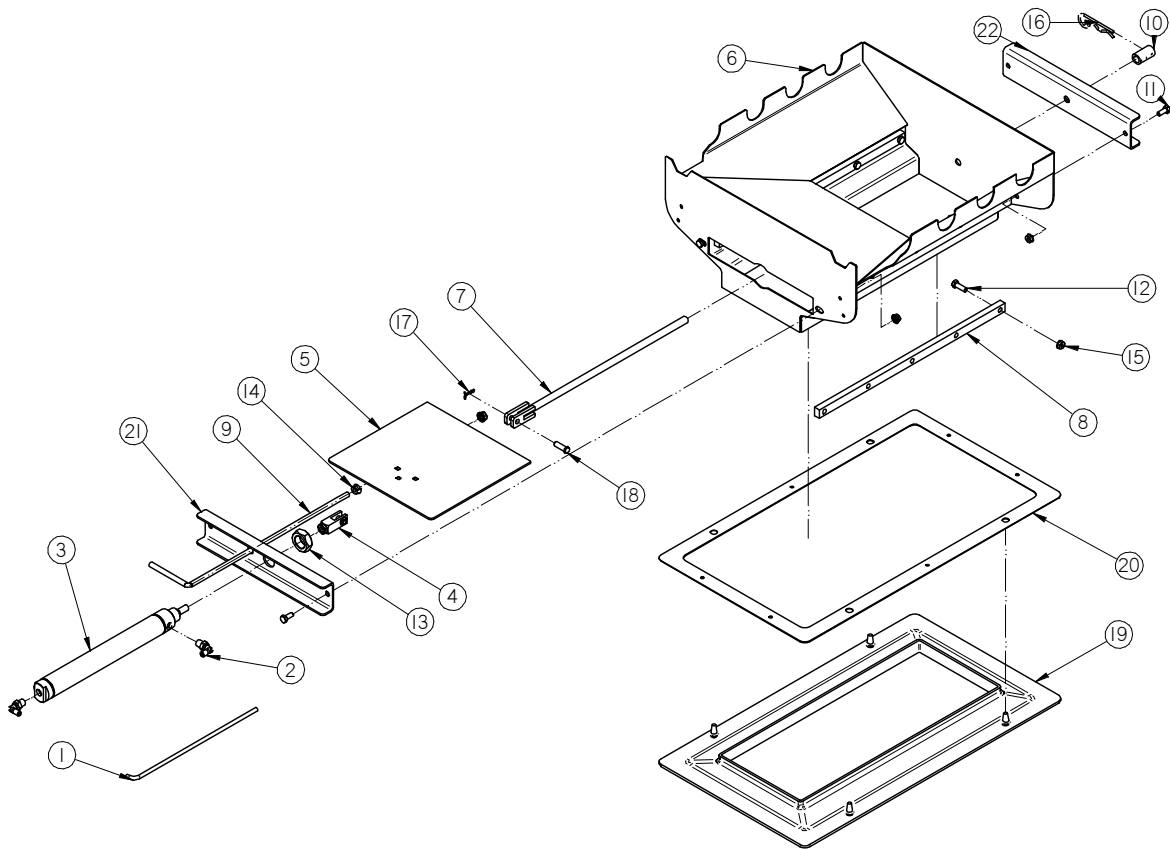

UNBERBIN CONVEYOR

ASSEMBLY UB HOPPER AMBER WAVES 8 INCH (13-05-0307 REV A3)

PART #		13-05-0307 REV A3	
Item #	Part #	Description	Qty
1	02-03-0051	TBG .250 OD NYL BLK	1.333
2	02-16-0044	FTTG PUSH 90 DEG .250OD X .250 NPT	2
3	03-17-0045	BIMBA CYL 10" ST 1.5 BR MRS-1710-DB	1
4	03-17-0046	CLEVIS ASSY BIMBA D-8311-A	1
5	05-03-1404	WDMT UB HOPPER SLIDE 8IN	1
6	05-03-1405	WDMT UB HOPP AM-WAVES 8IN	1
7	05-04-0078	WDMT SLGT STOP ROD	1
8	05-10-3103	PLT UB HOPP SLIDE BEARING	2
9	05-11-0197	UB HOPP SLIDE ROD	1
10	05-11-0268	SLV SLIDE GATE ADJ STOP	1
11	06-01-0010	BOLT .313-18 X .750 ZP GR5	4
12	06-01-0012	BOLT .313-18 X 1.00 ZP GR5	10
13	06-02-0067	NUT BIMBA D-1331	1
14	06-03-0014	NUT LOCK FLG .375-16 ZP GR5	2
15	06-03-0019	NUT LOCK FLG .313-18 ZP GR5	14
16	06-09-0002	PIN CLIP HITCH 3.063 SIZE 9 ZP	1
17	06-09-0013	PIN CTTR .125 X .75 ZP	1
18	06-09-0059	PIN CLVS .375 X 1.125 PLN	1
19	06-10-0048	SEAL RBBR SL GATE UB	1
20	102ECC	PLT UB HOPP SEAL	1
21	103247	PLT UB HOPP CYL MT	1
22	103248	PLT UB HOPP MT	1
23	13-10-0008	KIT INSTALL UB HOPP	1

UNDERBIN CONVEYOR

ASSEMBLY UB HOPPER EASTON 8 INCH (13-05-0358 REV A2)

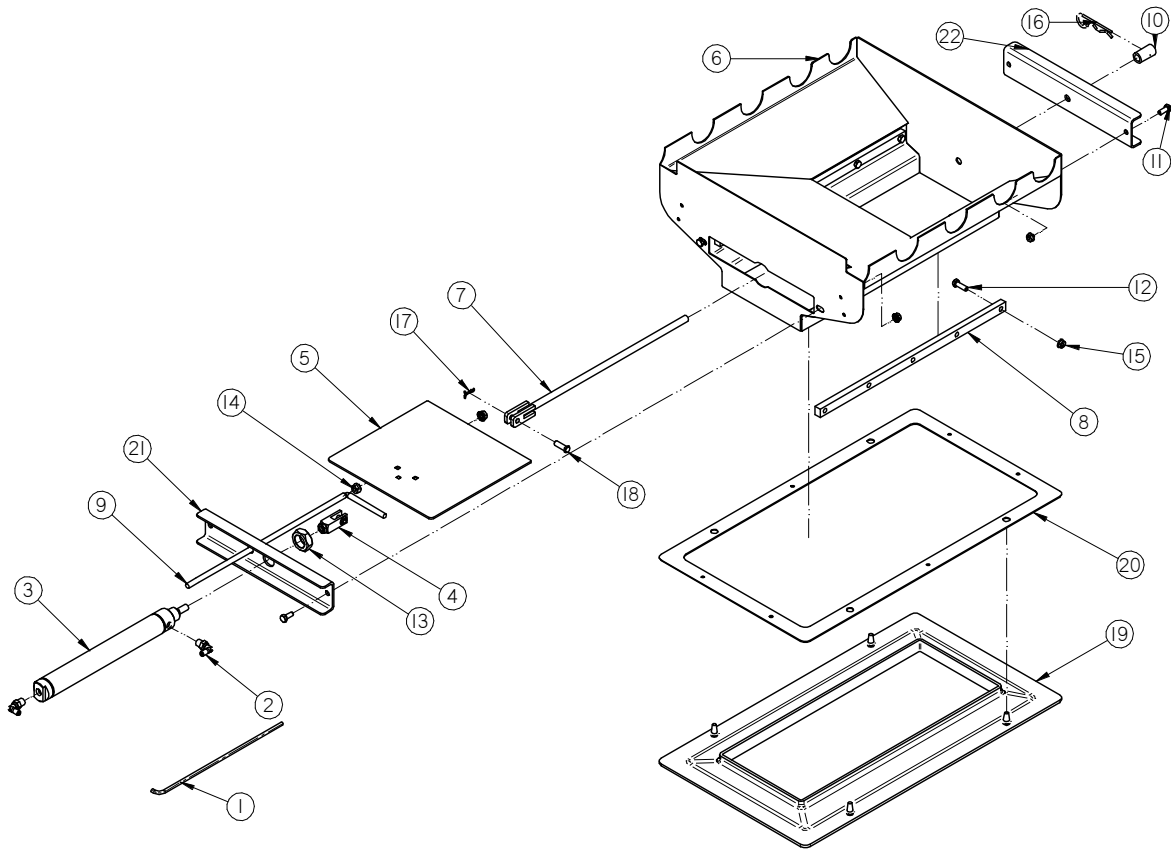

UNBERBIN CONVEYOR

ASSEMBLY UB HOPPER EASTON 8 INCH (13-05-0358 REV A2)

PART #		13-05-0258 REV A2	
Item #	Part #	Description	Qty
1	02-03-0051	TBG .250 OD NYL BLK	1.333
2	02-16-0044	FTTG PUSH 90 DEG .250OD X .250 NPT	2
3	03-17-0045	BIMBA CYL 10" ST 1.5 BR MRS-1710-DB	1
4	03-17-0046	CLEVIS ASSY BIMBA D-8311-A	1
5	05-03-1404	WDMT UB HOPPER SLIDE 8IN	1
6	05-03-1556	WDMT UB HOPP EASTON 8IN	1
7	05-04-0078	WDMT SLGT STOP ROD	1
8	05-10-3103	PLT UB HOPP SLIDE BEARING	2
9	05-11-0197	UB HOPP SLIDE ROD	1
10	05-11-0268	SLV SLIDE GATE ADJ STOP	1
11	06-01-0010	BOLT .313-18 X .750 ZP GR5	4
12	06-01-0012	BOLT .313-18 X 1.00 ZP GR5	10
13	06-02-0067	NUT BIMBA D-1331	1
14	06-03-0014	NUT LOCK FLG .375-16 ZP GR5	2
15	06-03-0019	NUT LOCK FLG .313-18 ZP GR5	14
16	06-09-0002	PIN CLIP HITCH 3.063 SIZE 9 ZP	1
17	06-09-0013	PIN CTRR .125 X .75 ZP	1
18	06-09-0059	PIN CLVS .375 X 1.125 PLN	1
19	06-10-0048	SEAL RBBR SL GATE UB	1
20	102ECC	PLT UB HOPP SEAL	1
21	103247	PLT UB HOPP CYL MT	1
22	103248	PLT UB HOPP MT	1
23	13-10-0008	KIT INSTALL UB HOPP	1

UNDERBIN CONVEYOR

ASSEMBLY UB HOPPER MERIDIAN 8 INCH MANUAL (13-05-0367 REV B0)

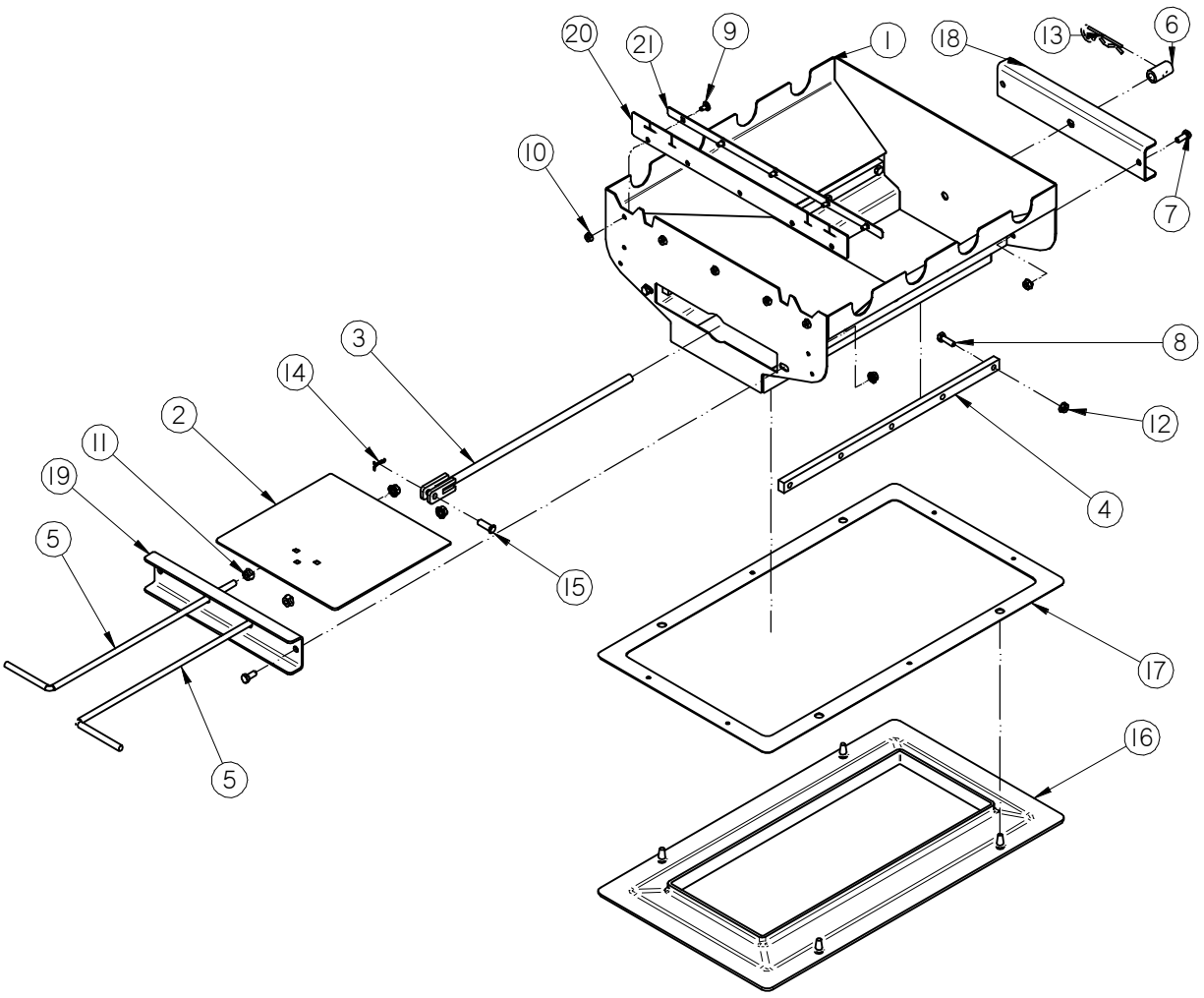

UNBERBIN CONVEYOR

ASSEMBLY UB HOPPER MERIDIAN 8 INCH MANUAL (13-05-0367 REV B0)

PART #		13-05-0367 REV B0	
Item #	Part #	Description	Qty
1	05-03-1370	WDMT UB HOPP MERIDIAN 8IN	1
2	05-03-1404	WDMT UB HOPPER SLIDE 8IN	1
3	05-04-0078	WDMT SLGT STOP ROD	1
4	05-10-3103	PLT UB HOPP SLIDE BEARING	2
5	05-11-0197	UB HOPP SLIDE ROD	2
6	05-11-0268	SLV SLIDE GATE ADJ STOP	1
7	06-01-0010	BOLT .313-18 X .750 ZP GR5	4
8	06-01-0012	BOLT .313-18 X 1.00 ZP GR5	10
9	06-01-0150	BOLT CRG .250-20 X .500 ZP	5
10	06-03-0013	NUT LOCK FLG .250-20 ZP GR5	5
11	06-03-0014	NUT LOCK FLG .375-16 ZP GR5	4
12	06-03-0019	NUT LOCK FLG .313-18 ZP GR5	14
13	06-09-0002	PIN CLIP HITCH 3.063 SIZE 9 ZP	1
14	06-09-0013	PIN CTTR .125 X .75 ZP	1
15	06-09-0059	PIN CLVS .375 X 1.125 PLN	1
16	06-10-0048	SEAL RBBR SL GATE UB	1
17	102ECC	PLT UB HOPP SEAL	1
18	103248	PLT UB HOPP MT	1
19	103DBC	PLT UB HOPP CNTL ROD GUIDE MNL CNTL	1
20	105B4D	SEAL GATE	1
21	105B5F	PLT SEAL BACKING	1
22	13-10-0008	KIT INSTALL UB HOPP	1

UNDERBIN CONVEYOR

ASSEMBLY UB HOPPER SCHULD BUSHNELL 8 INCH MANUAL
(13-05-0390 REV A0)

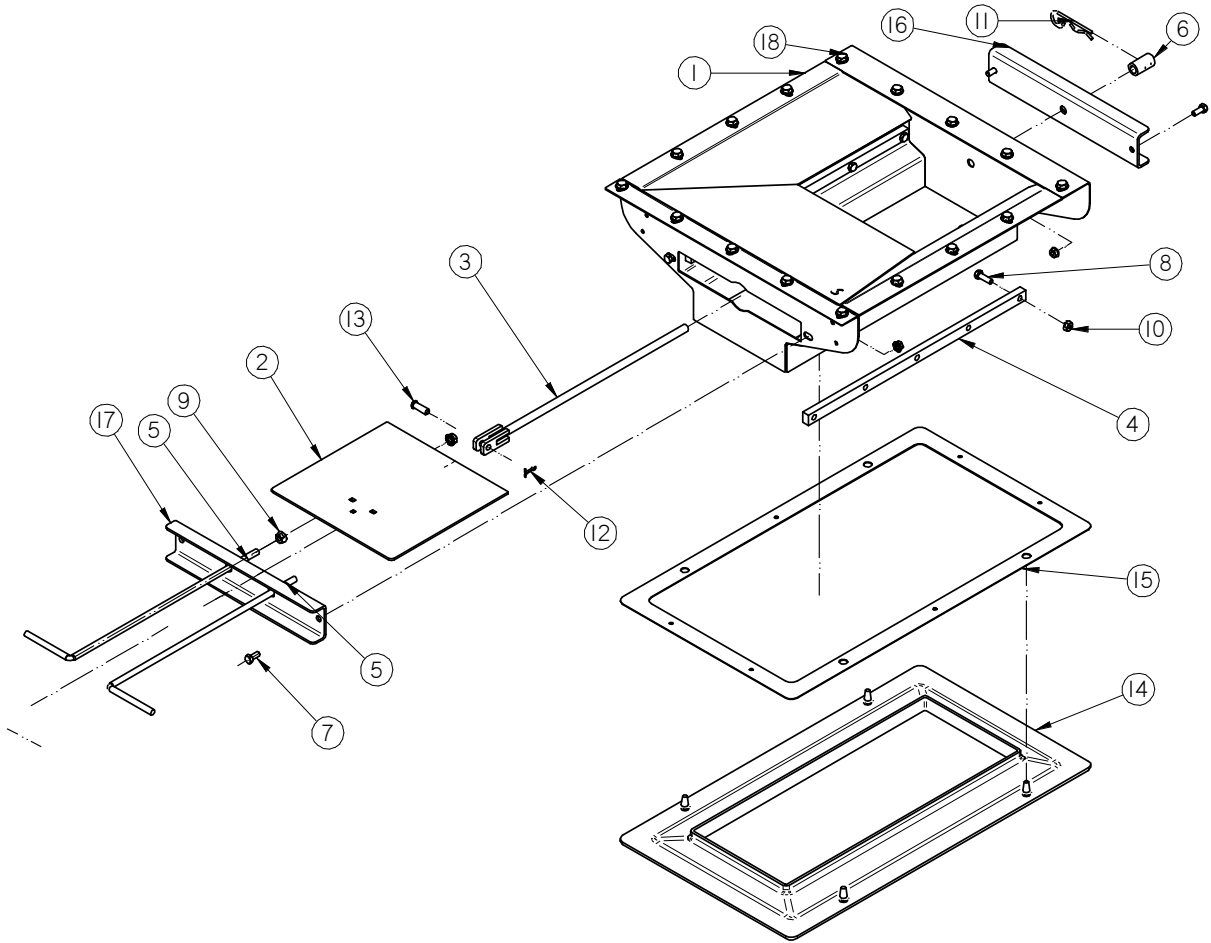

UNBERBIN CONVEYOR

ASSEMBLY UB HOPPER SCHULD BUSHNELL 8 INCH MANUAL
(13-05-0390 REV A0)

PART #		13-05-0390 REV A0	
Item #	Part #	Description	Qty
1	05-03-1371	WDMT UB HOPP SCH-BUSH 8IN	1
2	05-03-1404	WDMT UB HOPPER SLIDE 8IN	1
3	05-04-0078	WDMT SLGT STOP ROD	1
4	05-10-3103	PLT UB HOPP SLIDE BEARING	2
5	05-11-0197	UB HOPP SLIDE ROD	2
6	05-11-0268	SLV SLIDE GATE ADJ STOP	1
7	06-01-0010	BOLT .313-18 X .750 ZP GR5	4
8	06-01-0012	BOLT .313-18 X 1.00 ZP GR5	10
9	06-03-0014	NUT LOCK FLG .375-16 ZP GR5	4
10	06-03-0019	NUT LOCK FLG .313-18 ZP GR5	14
11	06-09-0002	PIN CLIP HITCH 3.063 SIZE 9 ZP	1
12	06-09-0013	PIN CTTR .125 X .75 ZP	1
13	06-09-0059	PIN CLVS .375 X 1.125 PLN	1
14	06-10-0048	SEAL RBBR SL GATE UB	1
15	102ECC	PLT UB HOPP SEAL	1
16	103248	PLT UB HOPP MT	1
17	103DBC	PLT UB HOPP CNTL ROD GUIDE MNL CNTL	1
18	13-10-0007	KIT INSTALL UB HOPP SCHULD-BUSHNELL	1

UNDERBIN CONVEYOR
GATE EXTENSION 8IN WIDE (05-08-0445 REV A0)

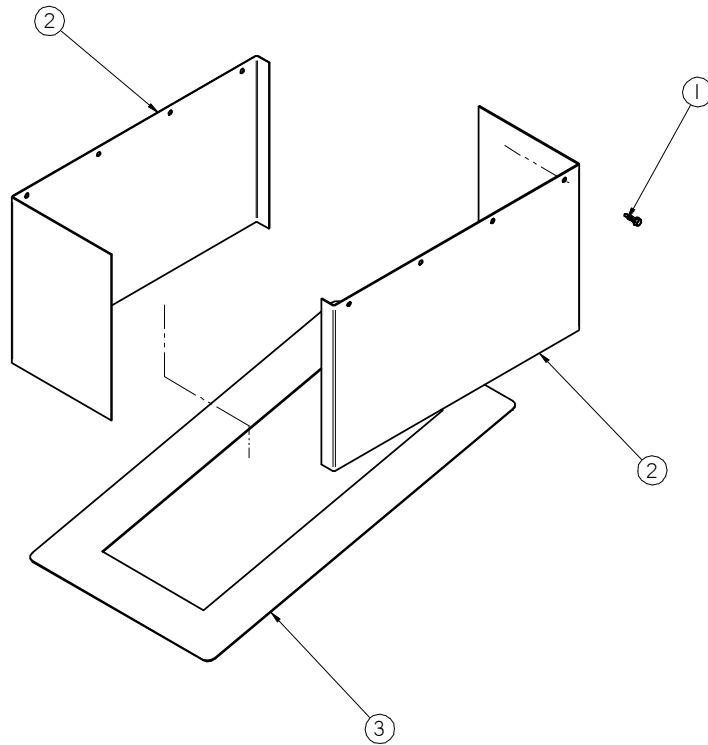

PART #		05-08-0445 REV A0	
Item #	Part #	Description	Qty
1	06-06-0037	SCRW SDST .250-14 X 1.000 HH ZP	12
2	103732	SIDE	2
3	103733	PLT UNDERBIN HOPP SEAL	1

UNBERBIN CONVEYOR
KIT UB CLEANOUT (13-05-0736 REV A1)

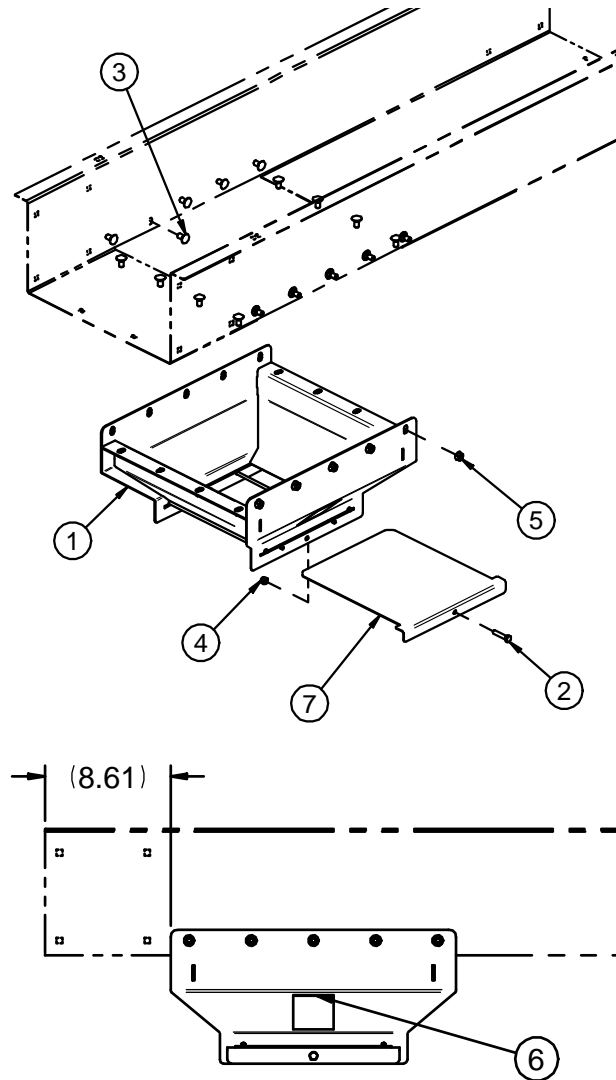

PART #		13-05-0736 REV A1	
Item #	Part #	Description	Qty
1	05-08-0742	WDMT CLEANOUT UB	1
2	06-01-0013	BOLT .313-18 X 1.50 ZP GR5	1
3	06-01-0153	BOLT CRG .375-16X.750 ZP SHORT NECK	18
4	06-03-0002	NUT NYL LOCK .313-18 ZP GR5	1
5	06-03-0014	NUT LOCK FLG .375-16 ZP GR5	18
6	09-02-0011	ATWK LBL WARNING MOVING PART	2
7	105E0A	PLT SLIDE CLEANOUT UB	1

UNDERBIN CONVEYOR
KIT UB ACCESS DOOR (13-05-0737 REV A0)

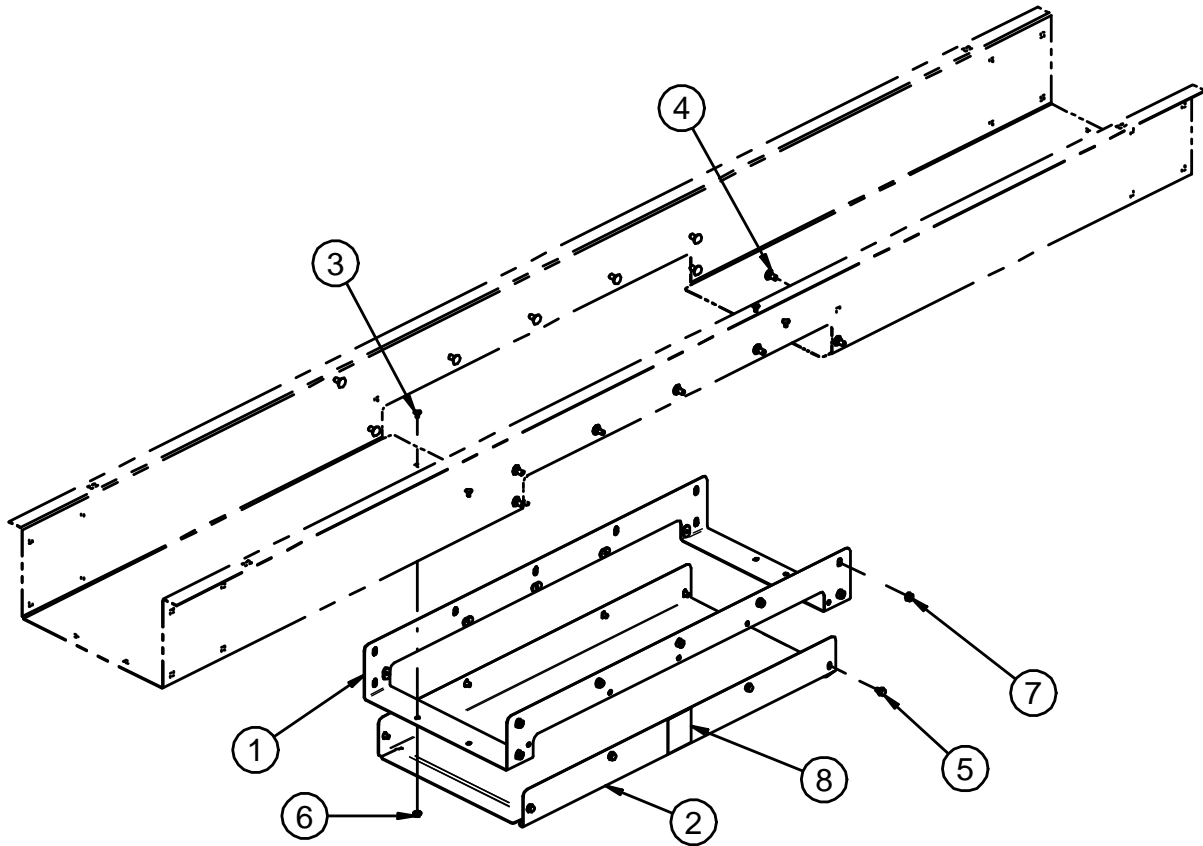

PART #		13-05-0737 REV A0	
Item #	Part #	Description	Qty
1	05-08-0480	WDMT ACCESS DOOR 16IN	1
2	05-10-4363	DOOR ACCESS 16IN	1
3	06-01-0150	BOLT CRG .250-20 X .500 ZP	4
4	06-01-0153	BOLT CRG .375-16X.750 ZP SHORT NECK	14
5	06-01-0261	BOLT FLG .3125-18 X .500 ZP GR5	8
6	06-03-0013	NUT LOCK FLG .250-20 ZP GR5	4
7	06-03-0014	NUT LOCK FLG .375-16 ZP GR5	14
8	09-02-0011	ATWK LBL WARNING MOVING PART	2

UNBERBIN CONVEYOR

ASSEMBLY UB INLET STUB 8 DIAMETER (13-05-0252 REV A2)

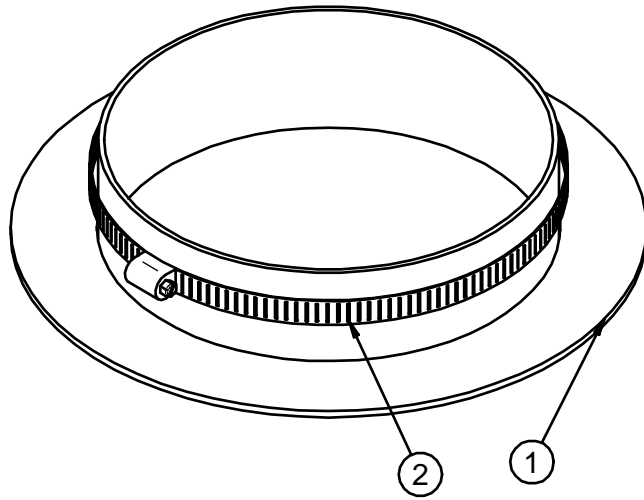

PART #		13-05-0252 REV A2	
Item #	Part #	Description	Qty
1	05-03-1116	WDMT UB INLET STUB 8 DIA	1
2	06-07-0024	CLMP HOSE 7.125 TO 10 X 9/16 SS	1

ASSEMBLY UB INLET STUB 10 DIAMETER (13-05-0750 REV A0)

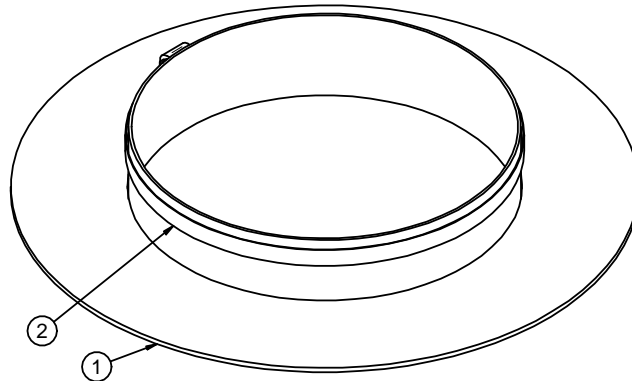

PART #		13-05-0750 REV A0	
Item #	Part #	Description	Qty
1	05-03-1856	WDMT UB INLET STUB 10 DIA	1
2	06-07-0027	CLMP HOSE 9.375 TO 12.25 X 9/16 SS	1

UNDERBIN CONVEYOR

PART NUMBER INDEX

DRAWING #	REV	DESCRIPTION	PAGE
		GENERAL ASSEMBLY	15
		MOTORS	16
		UB Belt Part numbers	46
05-05-0007	C0	KIT UB CNVR LEGS	47
05-05-0044	A1	KIT UB CNVR LEGS EXTD 16IN	48
05-05-0112	B0	ASSY UB CNVR HANGER LONG	49
05-08-0445	A0	GATE EXTENSION 8IN WIDE	66
13-05-0252	A2	ASSY UB INLET STUB 8 DIA	69
13-05-0293	B4	ASSY UB HOPP MERIDIAN 8IN	50
13-05-0294	A4	ASSY UB HOPP SCH-BUSH 8IN	52
13-05-0295	A4	ASSY UB HOPP YORK 8IN	54
13-05-0296	A4	ASSY UB HOPP WESTEEL 8IN	56
13-05-0307	A3	ASSY UB HOPP AM-WAVES 8IN	58
13-05-0332	A0	ASSY MANUAL TUBE MNT	29
13-05-0358	A2	ASSY UB HOPP EASTON 8IN	60
13-05-0367	B0	ASSY UB HOPP MERIDIAN 8IN MANUAL	62
13-05-0390	A0	ASSY UB HOPP SCH-BUSH 8IN MANUAL	64
13-05-0674	A1	ASSY UB HD	25
13-05-0675	A1	ASSY UB HD BOX STND	26
13-05-0676	A2	ASSY UB HD-HD CONN	28
13-05-0682	A2	ASSY RVRS UB CHUTE	37
13-05-0736	A1	KIT UB CLEANOUT	67
13-05-0737	A0	KIT UB ACCESS DOOR	68
13-05-0750	A0	ASSY UB INLET STUB 10 DIA	69
13-05-0845	A0	ASSY UB HD BOX STND 10IN	27
13-08-0462	B2	ASSY DUAL UB TAKE-UP SPLICE	43
13-08-0757	B0	ASSY UB HD SECT LG BRG	17
13-08-0758	A0	ASSY TRACKING PLT	21
13-08-0759	A0	ASSY TRACKING PLT SM	22
13-08-0760	A2	KIT DRV 7.5 & 10 HP 6.5IN DRV PLY	24
13-08-0766	B0	ASSY UB TAIL SECT	35
13-08-0767	A0	ASSY UB INTER 2.5FT	30
13-08-0769	A1	ASSY UB INTER 7.5FT W/CLNOUT	32
13-08-0770	A0	ASSY UB INTER 10FT	33
13-08-0771	A1	ASSY UB INTER 10FT W/CLEANOUT	34

UNBERBIN CONVEYOR

PART NUMBER INDEX

DRAWING #	REV	DESCRIPTION	PAGE
13-08-0773	B0	ASSY DUAL UB RVRS DSCHG W/CLNOUT	38
13-08-0774	A1	ASSY UB INTER 7.5FT LESS SPLICE	45
13-08-0786	B0	ASSY UB HD SECT LG BRG	39
13-08-0855	A1	KIT DRV 5 HP 6.5IN DRV PLY	23
13-08-0866	A0	ASSY UB INTER 5.0FT	31

UNDERBIN CONVEYOR

NOTES:

SECTION C USC LIMITED WARRANTY

USC, LLC, (Manufacturer) warrants its seed treating equipment as follows:

1. **Limited Warranty:** Manufacturer warrants that the Products sold hereunder will be free from defects in material and workmanship for a period of 18 months from date of shipment. If the Products do not conform to this Limited Warranty during the warranty period, Buyer shall notify Manufacturer in writing of the claimed defects and demonstrate to Manufacturer satisfaction that said defects are covered by this Limited Warranty. If the defects are properly reported to Manufacturer within the warranty period, and the defects are of such type and nature as to be covered by this warranty, Manufacturer shall, at its expense, furnish replacement Products or, at Manufacturer's option, replacement parts for the defective products. Shipping and installation of the replacement Products or replacement parts shall be at the Buyer's expense.
2. **Other Limits:** THE FOREGOING IS IN LIEU OF ALL OTHER WARRANTIES, EXPRESSED OR IMPLIED, INCLUDING BUT NOT LIMITED TO THE IMPLIED WARRANTIES OF MERCHANTABILITY AND FITNESS FOR A PARTICULAR PURPOSE. Manufacturer does not warrant against damages or defects arising from improper installation (where installation is by persons other than Manufacturer), against defects in products or components not manufactured by Manufacturer, or against damages resulting from such non-Manufacturer made products or components. Manufacturer passes on to the Buyer the warranty it received (if any) from the maker of such non-Manufacturer made products or components. This warranty also does not apply to Products upon which repairs and / or modifications have been effected or attempted by persons other than pursuant to written authorization by Manufacturer. This includes any welding on equipment which could damage electrical components. Manufacturer does not warrant against casualties or damages resulting from misuse and / or abuse of Products, improper storage or handling, acts of nature, effects of weather, including effects of weather due to outside storage, accidents, or damages incurred during transportation by common carrier.
3. **Exclusive Obligation:** THIS WARRANTY IS EXCLUSIVE. The sole and exclusive obligation of Manufacturer shall be to repair or replace the defective Products in the manner and for the period provided above. Manufacturer shall not have any other obligation with respect to the Products or any part thereof, whether based on contract, tort, strict liability or otherwise. Under no circumstances, whether based on this Limited Warranty or otherwise, shall Manufacturer be liable for lost profits, lost revenue, lost sales (whether direct or indirect damages), incidental, special, punitive, indirect or consequential damages.
4. **Other Statements:** Manufacturer's employees or representatives' oral or other written statements do not constitute warranties, shall not be relied upon by Buyer, and are not a part of the contract for sale or this limited warranty.
5. **Return Policy:** Approval is required prior to returning goods to Manufacturer. A restocking fee will apply.
6. **Entire Obligation:** This Limited Warranty states the entire obligation of Manufacturer with respect to the Products. If any part of this Limited Warranty is determined to be void or illegal, the remainder shall remain in full force and effect.

US / Canada Non-Exclusive 2016



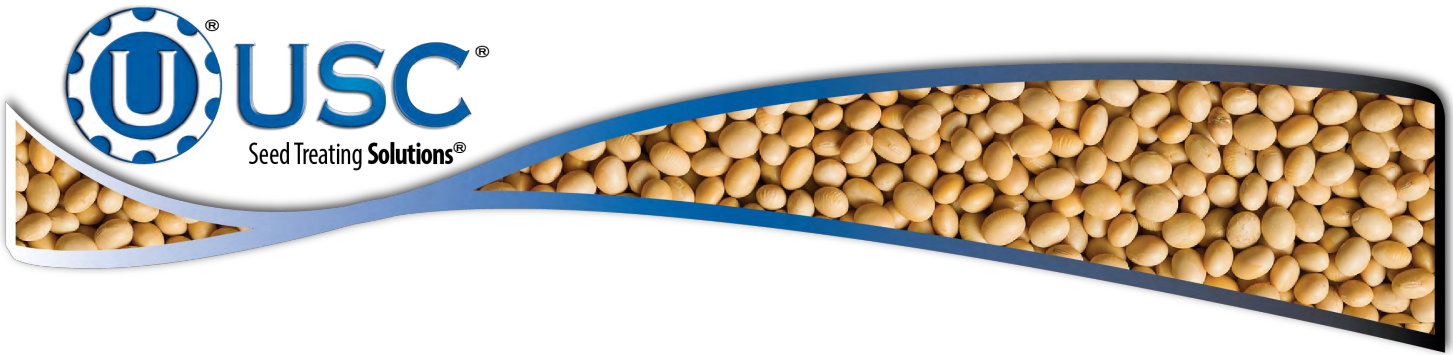

DOCUMENT REVIEW RECORD	
DATE	BY
08-20	BT

USC, LLC

2320 124th Road

Sabetha, KS 66534

Phone (785) 431-7900

EMAIL: sales-team@uscllc.com

WEB: www.uscllc.com

