

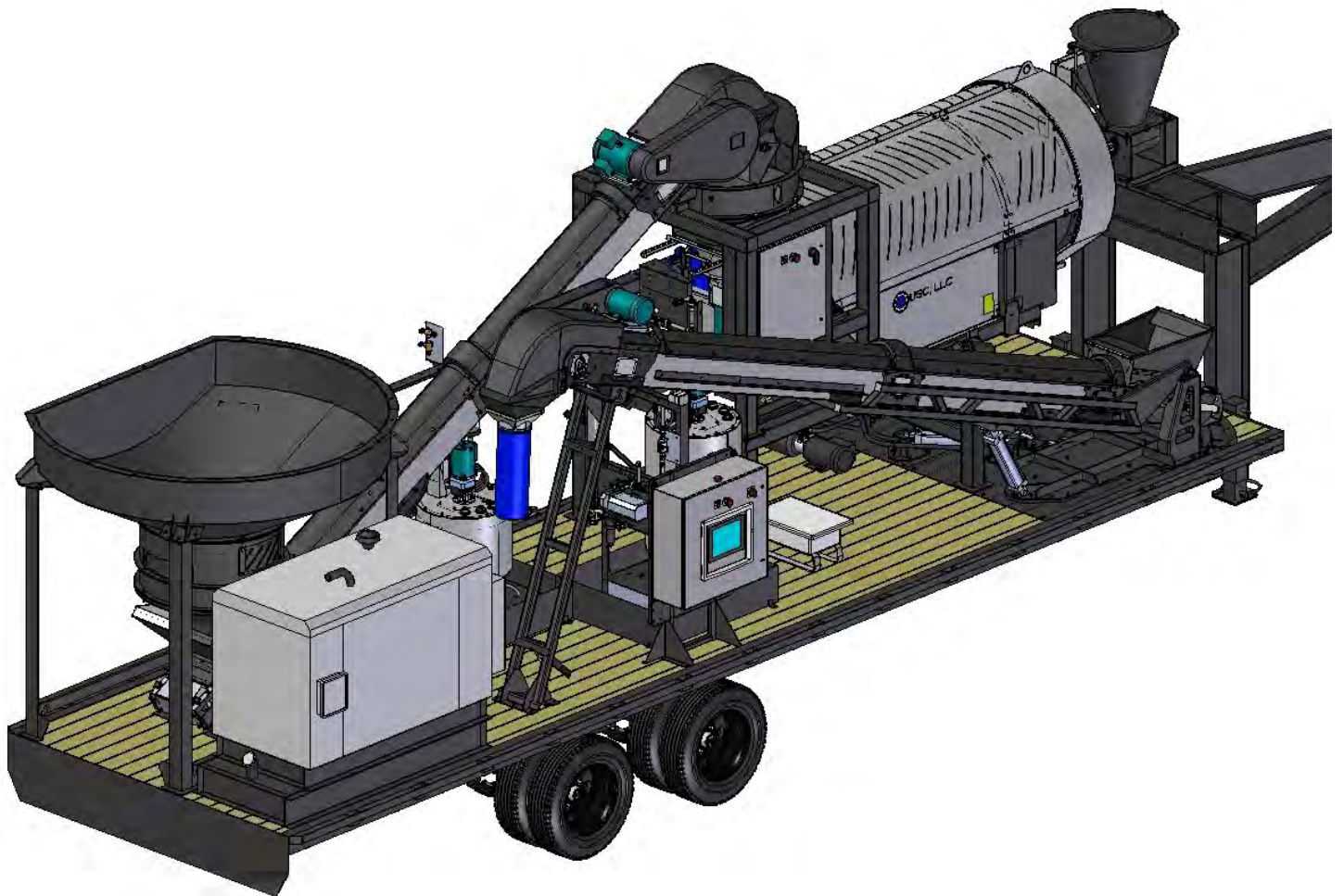

LPV PORTABLE SEED TREATER

Operators Manual



Document: TD-09-06-1052

Revision: A



INTRODUCTION

Thank you for choosing USC, LLC for your equipment needs. We appreciate your business and will work diligently to ensure that you are satisfied with your choice.

OVERVIEW

The purpose of this manual is to provide you with the basic information needed to operate and maintain the LPV Portable Treater. It does not hold USC, LLC liable for any accidents or injuries that may occur.

The technical information provided in this document is based on extensive testing under controlled conditions at the USC research and development facility. This information is given without guarantee as the conditions of operation and storage of the equipment are beyond our control. Variables such as temperature, humidity, viscosity of chemical products and changes in seed size or variety may all effect the accuracy of application and seed coverage. Periodically check the equipment calibration while treating and make adjustments as required. This will insure the optimum seed coverage.

OPERATOR RESPONSIBILITIES

As the purchaser/owner/operator of this equipment and control system, you have an obligation to install, operate, and maintain the equipment in a manner that minimizes the exposure of people in your care to any potential hazards inherent in using this equipment. It is critical that the owner of this equipment:

- Has a clear and documented understanding of the process this machine is being used in and of any resulting hazards or special requirements arising from this specific application.
- Allow only properly trained and instructed personnel to install, operate or service this equipment.
- Maintain a comprehensive safety program involving all who work with this machine and other associated process equipment.
- Establish clear areas of staff responsibility (e.g. operation, setup, sanitation, maintenance, and repairs).
- Provide all personnel with necessary safety equipment.
- Periodically inspect the equipment to insure that the doors, covers, guards, and safety devices are in place and functioning, that all safety instructions and warning labels are intact and legible, and that the equipment is in good working order.
- In addition to the operating instructions, observe and enforce the applicable legal and other binding regulations, national and local codes.

PORTABLE LPV TREATER

As the person with the most to gain or lose from working safely, it is important that you work responsibly and stay alert. By following a few simple rules, you can prevent an accident that could injure or kill you or a co-worker.

- Disconnect, lockout, and tagout electrical and all other energy sources before inspecting, cleaning, servicing, repairing, or any other activity that would expose you to the hazards of electrical shock.
- Do not operate, clean, or service this equipment until you have read and understood the contents of this manual. If you do not understand the information in this manual, bring it to the attention of your supervisor, or call USC at (785) 431-7900 for assistance.
- Any operator who is known or suspected to be under the influence of alcohol or drugs should not be allowed to operate the equipment.
- Understand and follow the safety practices required by your employer and this manual.
- **PAY ATTENTION** to what you and other personnel are doing and how these activities may affect your safety.
- **Failure to follow these instructions may result in serious personal injury or death.**

RECEIVING YOUR EQUIPMENT

As soon as the equipment is received, it should be carefully inspected to make certain that it has sustained no damage during shipment and that all items listed on the packing list are accounted for. If there is any damage or shortages, the purchaser must immediately notify USC, LLC. Ownership passes to purchaser when the unit leaves the USC, LLC. premises. The purchaser is responsible for unloading and mounting all components of the equipment.

Document the serial number of the conveyors for future reference. The serialization labels are located on the right side of each conveyor near the inlet end.

INLET CONVEYOR SERIAL NUMBER: _____

OUTLET CONVEYOR SERIAL NUMBER: _____



PORTABLE LPV TREATER

Document the vehicle identification number for future reference. On gooseneck trailers, the V.I.N. is located on a sticker on the side near the top of the gooseneck as shown below.

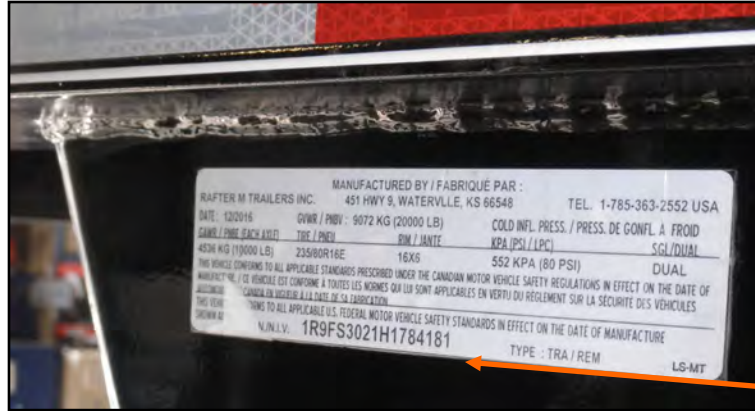

**V.I.N.
Number**

TRAILER V.I.N. NUMBER: _____

Document the vehicle identification number for future reference. On bumper hitch trailers, the V.I.N. is located on the side of the deck, in the left front corner.

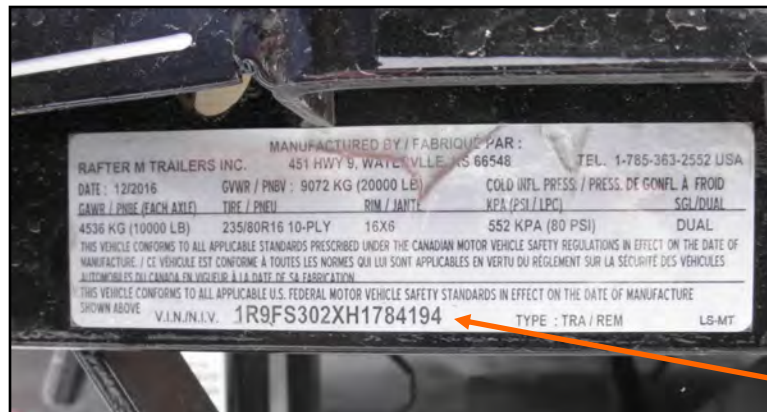

**V.I.N.
Number**

TRAILER V.I.N. NUMBER: _____

TABLE OF CONTENTS

<u>Section</u>	<u>Contents</u>	<u>Page #</u>
Section A	Safety Instructions.....	6
Section B	Installation	15
Section C	Mechanical Operation.....	17
	Fill Hopper, Inlet Conveyor.....	18
	Outlet Conveyor Hydraulics.....	18
	Outlet Conveyor.....	18
	Portable Treater Overview	19
Section D	Electrical Operation	21
	Treater Setup.....	22
	Preparing Treater for Transport.....	27
Section E	Troubleshooting.....	28
	Unplugging	29
Section F	Maintenance	30
Section G	Belt Tensioning Specification.....	35
Section H	Storage.....	36
Section I	Mechanical Drawings.....	38
Section J	Limited Warranty.....	87

**SECTION
A**

SAFETY INSTRUCTIONS

Every year accidents in the work place maim, kill and injure people. Although it may be impossible to prevent all accidents, with the right combination of training, operating practices, safety devices, and operator vigilance, the number of accidents can be significantly reduced. The purpose of this section is to educate equipment users about hazards, unsafe practices, and recommended hazard avoidance techniques.

SAFETY WORDS AND SYMBOLS

It is very important that operators and maintenance personnel understand the words and symbols that are used to communicate safety information. Safety words, their meaning and format, have been standardized for U.S. manufacturers and published by the American National Standards Institute (ANSI). The European Community (E.C.) has adopted a different format based on the International Standards Organization (I.S.O.) and applicable machinery directives. Both formats are presented below. Graphic symbols are not standardized, but most manufacturers will use some variation of the ones seen in this manual.



Indicates an imminently hazardous situation which, if not avoided, **will** result in death or serious injury.



Indicates a potentially hazardous situation which, if not avoided, **could** result in death or serious injury.



Indicates a potentially hazardous situation which, if not avoided, **may** result in minor or moderate injury and/or property damage.



Provides additional information that the operator needs to be aware of to avoid a potentially hazardous situation.



The minimum clearance height requirement for the LPV Portable Treater is the same as a standard semi trailer, 13 FEET 6 INCHES.



Mandatory Lockout Power Symbol. Disconnect, lockout and tagout electrical and other energy sources before inspecting, cleaning or performing maintenance on this panel.



International Safety Alert Symbol. The exclamation point (!) surrounded by a yellow triangle indicates that an injury hazard exists. However, it does not indicate the seriousness of potential injury. The exclamation point (!) is also used with the DANGER, WARNING and CAUTION symbols so the potential injury is indicated.



Electrocution Hazard Symbol. This symbol indicates that an electrocution hazard exists. Serious injury or death could result from contacting high voltage.



International Electrocution Hazard. This symbol indicates that an electrocution hazard exists. Serious injury or death could result from contacting high voltage.



Mandatory Read Manual Action Symbol. (I.S.O. format) This symbol instructs personnel to read the Operators Manual before servicing or operating the equipment.



Mandatory Read Manual Action Symbol. This symbol instructs personnel to read the Operators Manual before servicing or operating the equipment.

NOTICE

Notice is used to notify people of important installation, operation or maintenance information which is not hazard related.

LOCKOUT / TAGOUT PROCEDURES

Lockout/Tagout is the placement of a lock/tag on an energy isolating device in accordance with an established procedure. When taking equipment out of service to perform maintenance or repair work, always follow the lockout/tagout procedures as outlined in ANSI Z344.1 and/or OSHA Standard 1910.147. This standard “requires employers to establish a program and utilize procedures for affixing appropriate lockout devices or tagout devices to energy isolating devices and to otherwise disable machines or equipment to prevent unexpected energizing, start-up, or release of stored energy in order to prevent injury to employees.”

EMERGENCY STOP



There are three Emergency Stop push buttons on the Portable LPV Seed Treater. One is located on the I / O control panel mounted on the side of the treater, and one each on the Treater Control and Main Control Panels mounted on the side of the trailer. All Actuators of emergency stop shall be colored RED. The background immediately around the device actuator shall be colored YELLOW. The actuator pushbutton operated device shall be of the palm or mushroom head type.

NOTICE

If the treater is equipped with the optional portable generator, there is also an emergency stop on the generator that would shut down the power source. This is not the preferred method for emergency shutdown.

CONTROLLED STOP

This is the stopping of machine motion by reducing the electrical command signal to 0 (zero) once the stop signal has been recognized. The operator initiates this stop by pressing the PAUSE button at the bottom of the main screen.



WARNING

HAZARD REVIEW

Electrocution Hazard

Electrocution accidents are most likely to occur during maintenance of the electrical system or when working on or near exposed high voltage wiring. This hazard does not exist when the electrical power has been disconnected, properly locked, and tagged out.

Automatic Start Hazard

This equipment may be controlled by an automated system and may start without warning. Failure to properly disconnect, lockout, and tagout all energy sources of remotely controlled equipment creates a very hazardous situation and could cause injury or even death. PLEASE STAY CLEAR AND BE ALERT.

PORTABLE LPV TREATER

YOU are responsible for the **SAFE** operation and maintenance of your USC, LLC equipment . **YOU** must ensure that you and anyone else who is going to operate, maintain or work around the equipment be familiar with the operating and maintenance procedures and related **SAFETY** information contained in this manual. This manual will take you step-by-step through your working day and alert you to good safety practices that should be adhered to while operating the equipment

Remember, **YOU** are the key to safety. Good safety practices not only protect you, but also the people around you. Make these practices a working part of your safety program. Be certain that **EVERYONE** operating this equipment is familiar with the recommended operating and maintenance procedures and follows all the safety precautions. Most accidents can be prevented. Do not risk injury or death by ignoring good safety practices.

- Equipment owners must give operating instructions to operators or employees before allowing them to operate the machine, and at least annually thereafter per OSHA (Occupational Safety and Health Administration) regulation 1928.57.
- The most important safety device on this equipment is a **SAFE** operator. It is the operator's responsibility to read and understand **ALL** Safety and Operating instructions in the manual and to follow them. All accidents can be avoided.
- A person who has not read and understood all operating and safety instructions is not qualified to operate the machine. An untrained operator exposes himself and bystanders to possible serious injury or death.
- Do not modify the equipment in any way. Unauthorized modification may impair the function and/or safety and could affect the life of the equipment.
- Think SAFETY! Work SAFELY!

GENERAL SAFETY

1. Read and understand the operator's manual and all safety labels before operating, maintaining, adjusting or unplugging the equipment .
2. Only trained persons shall operate the equipment . An untrained operator is not qualified to operate the machine.
3. Have a first-aid kit available for use should the need arise, and know how to use it.



PORTABLE LPV TREATER

4. Provide a fire extinguisher for use in case of an accident. Store in a highly visible place.
5. Do not allow children, spectators or bystanders within hazard area of machine.
6. Wear appropriate protective gear. This includes but is not limited to:
 - A hard hat
 - Protective shoes with slip resistant soles
 - Protective goggles
 - Heavy gloves
 - Hearing protection
 - Respirator or filter mask
7. Place all controls in neutral or off, stop motor, and wait for all moving parts to stop. Then disable power source before servicing, adjusting, repairing, or unplugging.
8. Review safety related items annually with all personnel who will be operating or maintaining the equipment.



OPERATING SAFETY:

1. Read and understand the operator's manual and all safety labels before using.
2. Disconnect and disable electrical supply completely and wait for all moving parts to stop before servicing, adjusting, repairing or unplugging.
3. Clear the area of bystanders, especially children, before starting.
4. Be familiar with the machine hazard area. If anyone enters hazard area, shut down machine immediately. Clear the area before restarting.
5. Keep hands, feet, hair and clothing away from all moving and/or rotating parts.
6. Stay away from overhead obstructions and power lines during operation and transporting. Electrocutation can occur without direct contact.
7. Do not operate machine when any guards are removed.
8. Inspect welds and repair if needed.

PORTABLE LPV TREATER

PLACEMENT SAFETY

1. Move only with the appropriate equipment.
2. Ensure there is enough clearance from overhead obstructions and other equipment to move the machine into its working position. 13 feet 6 inches is required to clear the top of the inlet conveyor.
3. Stay away from overhead power lines when moving equipment. Electrocution can occur without direct contact.
4. Operate the equipment on level ground free of debris. **USC strongly recommends that the trailers is attached to the tow vehicle whenever the discharge conveyor is deployed and the treating system is in use.**

MAINTENANCE SAFETY

1. Review the operator's manual and all safety items before working with, maintaining or operating the equipment .
2. Place all controls in neutral or off, stop motors, disable power source, and wait for all moving parts to stop before servicing, adjusting, repairing or unplugging.
3. Follow good shop practices:

Keep service area clean and dry.

Be sure electrical outlets and tools are properly grounded.

Use adequate light for the job at hand.
4. Keep hands, feet, hair and clothing away from all moving and/or rotating parts.
5. Clear the area of bystanders, especially children, when carrying out any maintenance and repairs or making any adjustments.
6. Before resuming work, install and secure all guards when maintenance work is completed.



SAFETY LABELS

1. Keep safety labels clean and legible at all times.
2. Replace safety labels that are missing or have become illegible.
3. Replaced parts that displayed a safety label should also display the current label.
4. Replacement safety labels are available. Contact USC at (785) 431-7900 .

How to Install Safety Labels:

- Be sure that the installation area is clean and dry.
- Be sure temperature is above 50°F (10°C).
- Decide on the exact position before you remove the backing paper.
- Remove the smallest portion of the split backing paper.
- Align the sign over the specified area and carefully press the small portion with the exposed sticky backing in place.
- Slowly peel back the remaining paper and carefully smooth the remaining portion of the sign in place.
- Small air pockets can be pierced with a pin and smoothed out using the piece of sign backing paper.



Located on the USC equipment you will find safety labels. Always be sure to read and follow all directions on the labels.



Guards provided with USC equipment are to remain in place during operation.

PORTABLE LPV TREATER

Think **SAFETY!** Work **SAFELY!**

REMEMBER—If safety labels have been damaged, removed, become illegible, or parts replaced without safety labels, new labels must be applied. New safety labels are available from USC at (785) 431-7900.



Part # 09-02-0003



Part # 09-02-0010



Part # 09-02-0015



Part # 09-02-0001



Part # 09-02-0002

PORTABLE LPV TREATER



Part # 09-02-0007



Part # 09-02-0006



Part # 09-02-0011



Part # 09-02-0009



Part # 09-02-0012

INSTALLATION SECTION B



HIGH VOLTAGE ~ Always disconnect the power source before working on or near the control panel or lead wires.



HIGH VOLTAGE ~ Use insulated tools when making adjustments while the controls are under power.

1. If the treater does not come equipped with a generator, or you are supplying your own generator, have a certified electrician provide power to the seed treating system. The treater panel is the only equipment that is hard wired (below). This will power the USC LPV Seed treater and any attached conveyors. All other equipment requires a properly grounded 110V source. Provide convenient shutdown switches, comply with local electrical codes and ensure that the system is properly grounded and bonded. All USC control panels must be connected adhering to the same electrical requirements as specified in the main control panel on the power requirement tag (right), or the electrical schematic shipped with the piece of equipment.

Mfg. By: USC, LLC
 Max voltage: 230V, 1PH, 60 HZ
 Total FLA: 112
 Largest Motor FLA: 40
 Schematic number: 13-12-0126A
 Enclosure rating: UL type 1
 Short Circuit Current Rating:
 5ka RMS Sym, 600V Max

WARNING
 To maintain over-current, short-circuit and ground-fault protection, the manufacturer's instruction for installation of over-current and short-circuit protection must be followed. To reduce the risk of fire or electrical shock.

WARNING
 If an overload or a fault current interrupter opens, circuits must be checked to determine the cause of the interruption. If a fault condition persists, the corresponding components should be examined and replaced if damaged, and the integral current sensors must be replaced to reduce the risk of fire or electrical shock.

TREATER CONTROL PANEL
 See schematic number: 13-12-0126A
 for interconnections

Replacement Fuse Chart				
Fuse	Line	Size	Type	
FU2006	2006	2008	50A	CLASS CC 600V
FU2010	2010	2012	10A	CLASS CC 600V
FU2101	2101	2103	10A	CLASS CC 600V

WARNING!
 230V/1PH/60Hz supply only.
 0 to Neutral voltage must not exceed 120 Volts.



A minimum rating of 34 KW is required when using a generator with the system.

Incoming power connected to these terminals in the Treater Control Panel

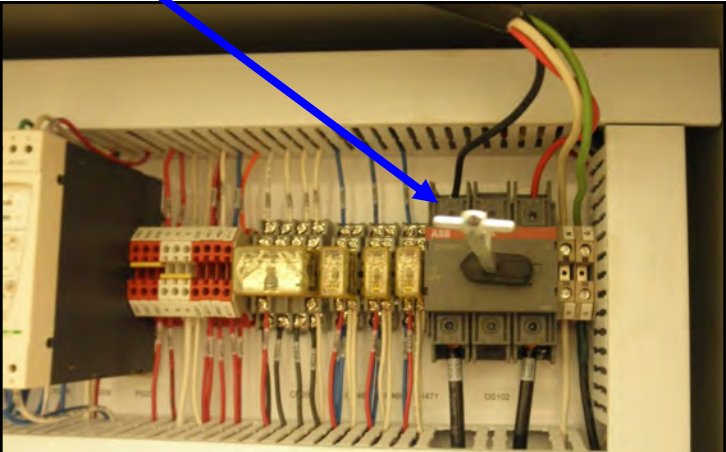

PORTABLE LPV TREATER

INSTALLATION

2. Remove any boxes from the drum of the treater.
3. Inspect machine thoroughly for screws, bolts, fittings, etc. which may have come loose during shipping.
4. If not using a generator, disconnect power before moving the treater to another location.



When using a generator as a power source, USC recommends grounding the treating system according to local electrical codes. Two ground lugs are provided on the trailer. One at the left front corner and one on the right rear corner of the trailer.



MECHANICAL OPERATION

SECTION C

OPERATING SAFETY

<ol style="list-style-type: none"> 1. Read and understand the Operator's Manual and all safety signs before using. 2. Electric motor drives: Disconnect and disable electrical supply completely and wait for all moving parts to stop before servicing, adjusting, repairing or unplugging. 3. Clear the area of bystanders, especially children, before starting. 4. Be familiar with machine hazard area. If anyone enters hazard areas, shut down machine immediately. Clear the area before restarting. 5. Keep hands, feet, hair and clothing away from all moving and/or rotating parts. 6. Do not allow riders on the Conveyor or transport vehicle when transporting. 	<ol style="list-style-type: none"> 7. Stay away from overhead obstructions and power lines during operation and transporting. Electro-cution can occur without direct contact. 8. Do not operate machine when any guards are removed. 9. Lower Conveyor to its lowest position before moving or transporting or when not in use. 10. Inspect lift cable before using Conveyor. Replace if frayed or damaged. 11. Make certain lift cable is properly seated in cable pulleys. 12. Be sure that conveyor is empty before raising or lowering.
--	--

The Tube Series Conveyor is designed to efficiently move seed between a storage facility or seed totes and a truck, trailer or seed treater. Power is provided by an electric motor. Be familiar with the machine before starting.

It is the responsibility of the owner or operator to read this manual and to train all other operators before they start working with the machine. In addition to the design and configuration of equipment, hazard control and accident prevention are dependent upon the awareness, concern, and prudence of personnel involved in the operation, transport, maintenance and storage of equipment or in the use and maintenance of facilities.

NOTICE

Follow all safety instructions exactly. Safety is everyone's business. By following recommended procedures, a safe working environment is provided for the operator, bystanders and the area around the worksite. Untrained operators are not qualified to operate the machine.

Many features incorporated into this machine are the result of suggestions made by customers like you. Read this manual carefully to learn how to operate the machine safely and how to set it to provide maximum efficiency. By following the operating instructions in conjunction with a good maintenance program, your conveyor will provide many years of trouble free service.

PORTABLE LPV TREATER OVERVIEW

FILL HOPPER

The fill hopper holds 65 units of seed. The hopper feeds into the inlet conveyor using a rack and pinion gate.

INLET CONVEYOR

The 17 foot inlet conveyor feeds into the seed treater supply hopper. The conveyor plugs into a receptacle on the bottom of the treater control panel marked (Inlet Conveyor). The inlet conveyor is tied in with a proximity switch located in the 8 inch hopper extension ring. When seed reaches up and covers the proximity switch, the inlet conveyor will automatically shut-off so the hopper will not overflow. The conveyor will remain off until seed drops below the proximity switch. When the proximity sensor no longer detects seed, a timer relay will begin to count down to a pre-set time and turn the conveyor back on. The time delay prevents the conveyor from turning on and off too quickly.

NOTICE

If the inlet conveyor will not turn on after being shut down awhile, this may mean the proximity switch is malfunctioning. Refer to the Proximity Switch Adjustment Guide in the U-Treat manual.

OUTLET CONVEYOR HYDRAULICS

The outlet conveyor is stored for transportation parallel to the trailer. An electric powered motor drives the hydraulic system that deploys the conveyor to an operating position, and then returns it to the transporting position after the treating process is complete. The conveyor must always be at a full 90 degrees from the trailer when in use.

OUTLET CONVEYOR

As seed passes through the length of the treater drum, it is tumbled, producing accurate and uniform seed coating. The seed then exits the seed treater out the discharge chute of the machine and into the 20 foot outlet conveyor. The conveyor plugs into a receptacle on the bottom of the treater control panel marked (Outlet Conveyor). The seed is then discharged into a pro box, trailer, or any other container.

CAUTION

Never allow exposure of persons or clothing to the drive shaft, idler wheels, or the treater drum during operation. Always have the safety shields in place during operation.

PORTABLE LPV TREATER
PORTABLE LPV TREATER OVERVIEW

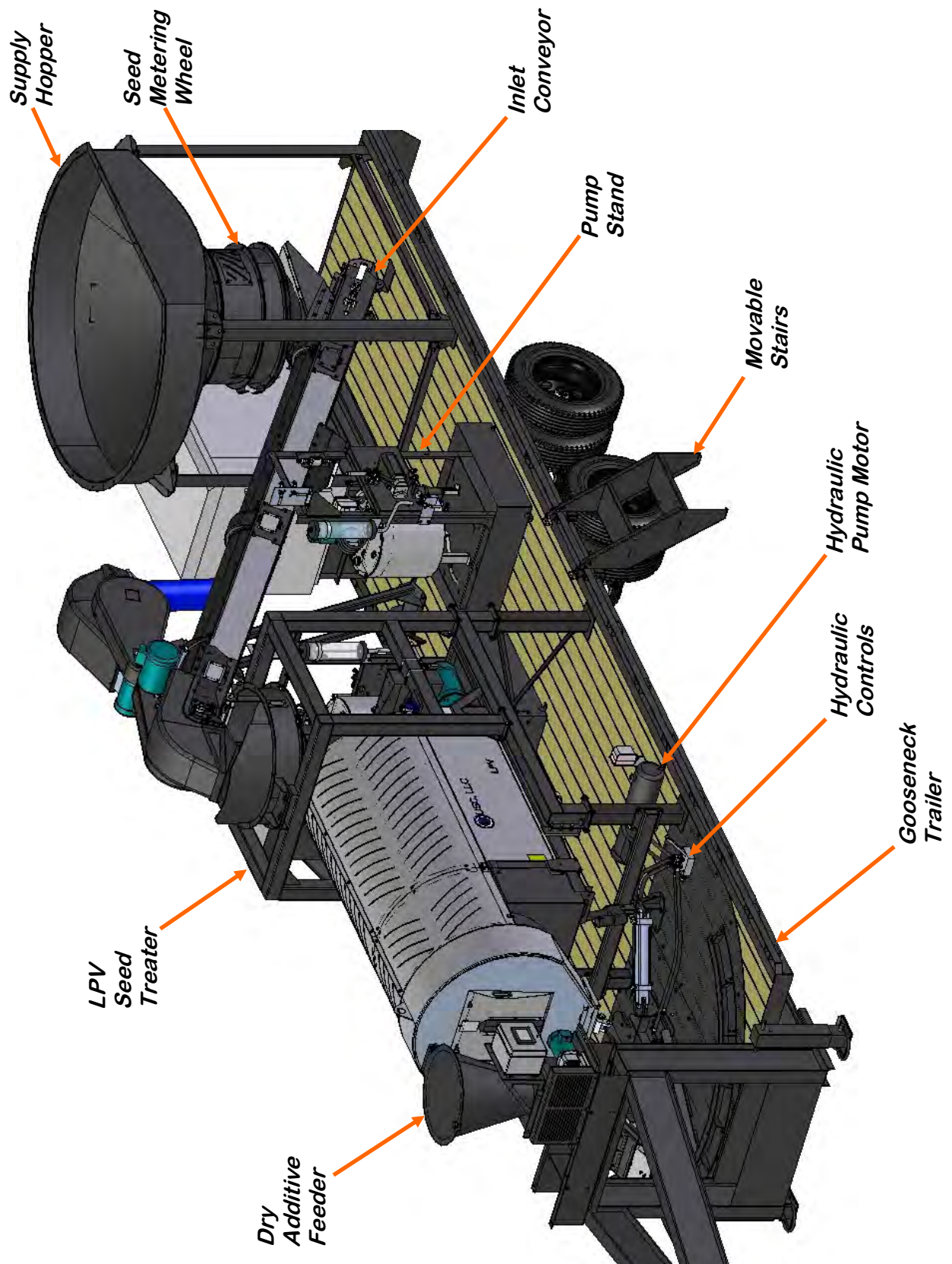

PORTABLE LPV TREATER
PORTABLE LPV TREATER OVERVIEW

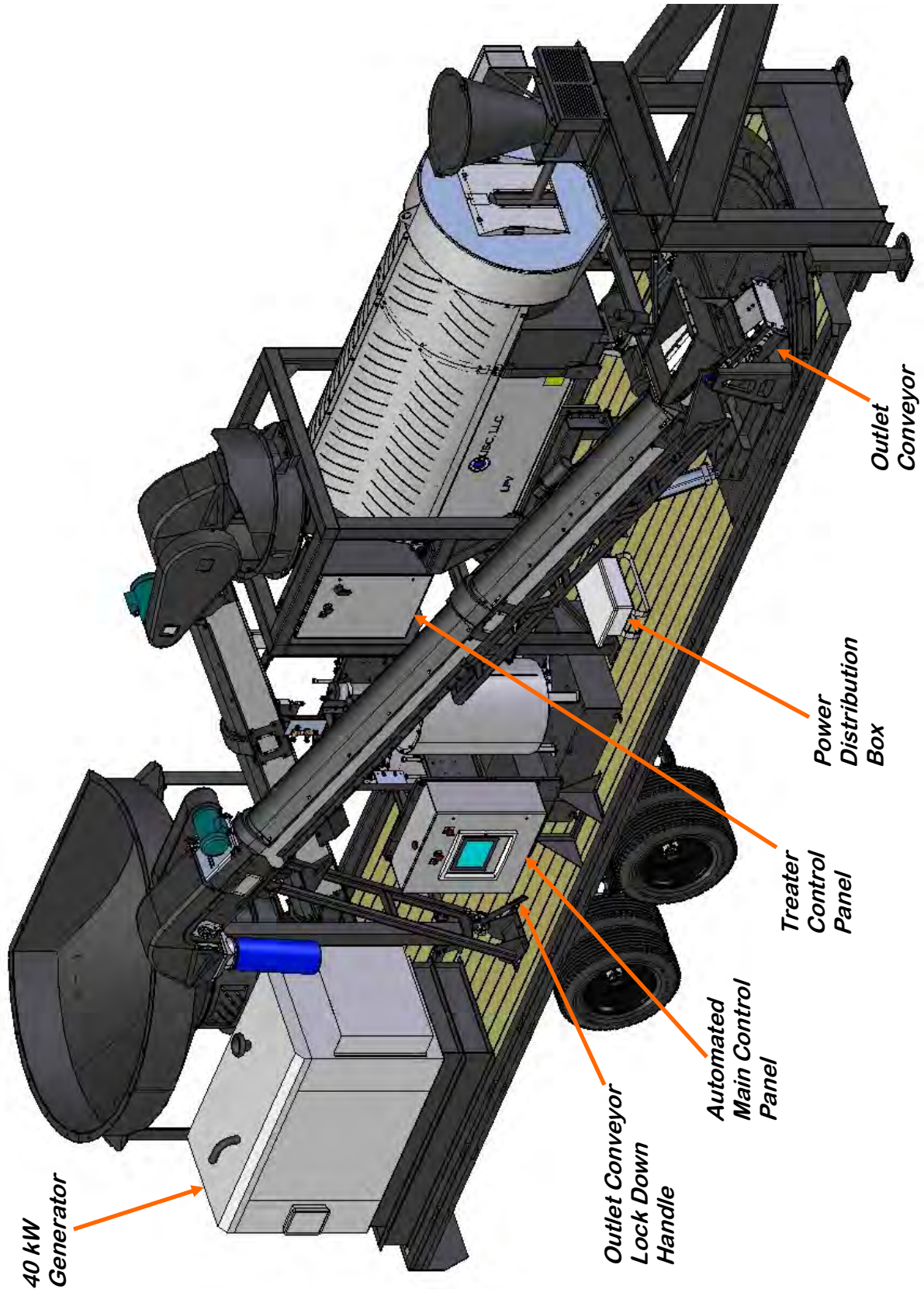

ELECTRICAL OPERATION

SECTION D



HIGH VOLTAGE ~ Always disconnect the power source before working on or near the control panel or lead wires.



HIGH VOLTAGE ~ Use insulated tools when making adjustments while the controls are under power.



AUTHORIZED PERSONNEL only shall work on the control panel. Never allow anyone who has not read and familiarized themselves with the owner's manual to open or work on the control panel.

This section provides a general overview and description of the operator controls for the Portable LPV Treater.



USC recommends the use of a surge protection device with a minimum rating of 400 Joules for all automated main control panels.

General Panel Descriptions:

All three panels are located side by side on the right side of the trailer at the center.

- The U-Connect-Pro Control Panel is an enclosure that contains the HP T620 Thin Client. This device converts the user supplied internet signal and sends it to the main control panel. Power to this panel is supplied from a power cable to a standard 115V outlet.
- The LPV Treater Control Panel is an enclosure that contains the electrical components required to actuate the seed treater. This includes the VFDs for the seed wheel and atomizer. Power for the treater is supplied here. Power to this panel is hard wired.
- The Automated Main Control Panel is a plug connected enclosure. It contains the PLC (Programmable Logic Controller) as well as the HMI (Human Machine Interface) touch screen. The operator is able to control the entire system through the HMI. Power to this panel is supplied from a power cable to a standard 115V outlet.

PORTABLE LPV TREATER

For the LPV Automated Treater HMI Touch screens, see the appropriate U-Treat Automation manual.

TREATER SET UP



USC strongly recommends that the trailers is attached to the tow vehicle whenever the discharge conveyor is deployed and the treating system is in use.

The following steps outline the set-up of your USC Portable LPV Treater :

1. Clear the area of bystanders, especially small children, before moving.
2. Attach the Portable System to an appropriate towing vehicle.
3. Ensure there is enough clearance from overhead obstructions and power lines or other equipment to move the machine into its working position. 13 feet 6 inches is required to clear the top of the inlet conveyor.
4. Move the portable system to a desired position on a level surface ensuring the machine remains stable during the treating process.
5. Set the park brake on the towing vehicle before dismounting.
6. Lower the trailer jacks to provide additional stability during the treating process. If you are going to operate without the tow vehicle attached, the trailer may not be more than **5 degrees** low on the discharge conveyor side. With the vehicle attached the angle may be no more than **10 degrees**. Use the trailer jacks to make the trailer as level as possible. If the angle is too steep, the equipment may topple or work improperly, damaging the equipment and or causing personal injury.

7. Remove the Clevis pins from both sides of the portable steps (left), and rotate them into the working position (right). Insert both pins back into the mounting bracket to avoid misplacing them.

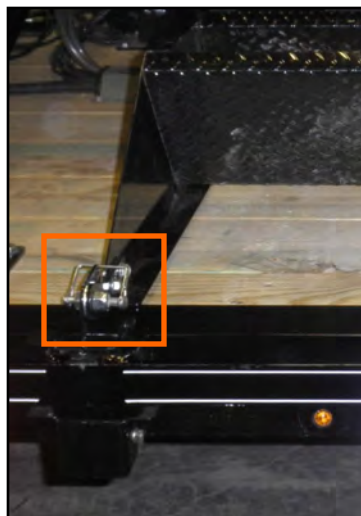

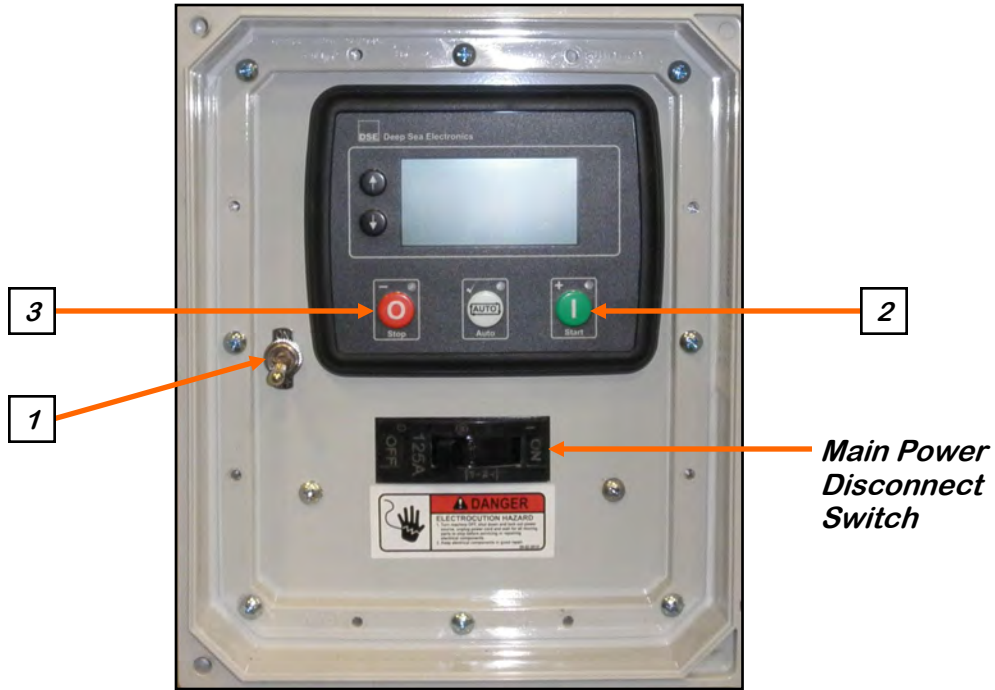

PORTABLE LPV TREATER
GENERATOR OPERATION

8. If using a fixed power source, provide power using the instructions on page 15. If using the USC provided generator, follow steps one through four to operate the generator. Before you start the generator, ensure that all switches on the treater, pumps stands, hydraulic motor and control panels as well as the main disconnect switch on the generator are in the OFF position.



STEP 1 - Turn On Panel Display: Move the control panel power switch up into the ON position. The display will turn on and the red LED on the start switch will begin to flash on and off. The icon in the lower right corner indicates what mode of manual operation the generator is in. See table below.



	Appears when the engine is at rest and the unit is waiting for a manual start.
	Appears when a timer is active, for example cranking time, crank rest etc.
	Appears when the engine is running, and all timers have expired, either on or off load. The animation speed is reduced when running in idle mode.

PORTABLE LPV TREATER
GENERATOR OPERATION

8. (Continued).

STEP 2: Start Generator. Press the green Start button on the generator. There will be a short pause for system checks, then generator will begin cranking over to start. Once the generator is running, the display will show the voltage ramping up from 0 to 120 volts and an hour glass will appear in the lower right corner of the screen until both voltages read 120v.

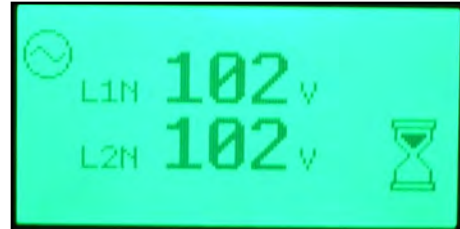

NOTICE

If the generator fails to start after cranking for ten seconds, it will pause for ten seconds and then begin cranking a second time. If it fails to start after three attempts it will stop and display an error message. Example: Low Fuel Level or Battery Under Voltage. Once the problem is resolved, press the Start button again.

When L1N and L2N have reached 120v the hour glass will turn into a motor piston moving up and down. The generator is ready for use. Move the main power disconnect switch to the right into the ON position. Power is now available to the control panels, spider box and hydraulic motor power switch.



STEP 3: Shutdown Generator. When you are done treating, turn off the treater panel, main control panel, pump stand mix motors and hydraulic motor. Move the main disconnect switch to the left placing it in the OFF position. Shutdown the generator by pressing the red Stop button. The hour glass will come back and after the preset time elapses it will gradually reduce speed until it shutdown. After it has stopped running, move the control panel power switch down to the OFF position. If left on it will drain the generator battery.

For an operators manual with more detailed information regarding the display functions go to the Deep Sea Electronics website and download document number 057-260 at: <https://www.deepseapl.com/genset/manual-auto-start-control-modules/dse4510>

PORTABLE LPV TREATER

TREATER SET UP

9. Now that the generator is up and running, Turn on the power to the treater, treater I / O and Main Control Panels.

10. Use the following steps to deploy the discharge conveyor.

STEP 1: Remove the hitch pin from the treater drum transport bracket located next to the drum actuator.

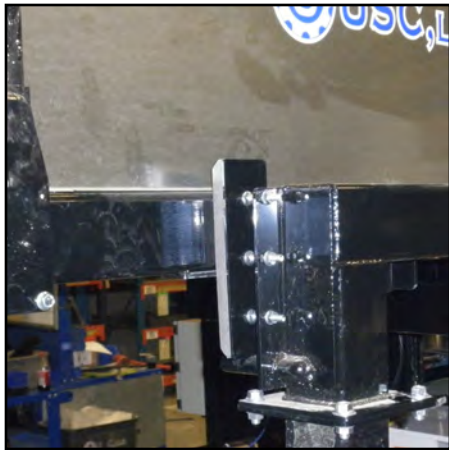

Hitch Pin

STEP 2: Go to the main control panel HMI treater main screen. Press the HOA button. Press and hold the UP button on the drum actuator module and raise the drum until the inside drum frame is level with or above the outside treater frame.

STEP 3: Remove the hitch pin from the outlet conveyor lockdown handle (bottom, left). Hold the latch rod in one hand and lift the handle with the other hand until the latch crossbar clears the conveyor lock on the conveyor head. Allow the latch rod to rest at the bottom of the slot on the supprt plate (bottom, right). The conveyor is now ready to move to a working position.



Hitch Pin



PORTABLE LPV TREATER

TREATER SET UP



STEP 4: Press the black start button on the hydraulic motor power switch.

STEP 5: Use the left control lever to raise the outlet conveyor until it is out of the cradle.



STEP 6: Use the right control lever to rotate the outlet conveyor out until it reaches the dead stop, a full 90 degrees from the trailer.

STEP 7: Use the left control lever to raise the outlet conveyor until it is high enough to clear the receptacle you will be discharging the treated seed into.



NOTICE

After the outlet conveyor has been moved into a working position, you may turn off the hydraulic motor. It is only necessary for it to be running when moving the conveyor.

PREPARING TREATER FOR TRANSPORT

1. Run the system until all of the seed is out of the treater and the outlet conveyor.
2. Go to the main control panel HMI treater main screen. Press the HOA button. Press and hold the UP button on the drum actuator module and raise the drum until the inside drum frame is level with or above the outside treater frame.
3. Use the right control lever to rotate the outlet conveyor in until it reaches the dead stop and is now parallel with the trailer.
4. Use the left control lever to lower the outlet conveyor until it is resting inside of the cradle.
5. Turn off the hydraulic motor.
6. Secure the outlet conveyor by following step three of the treater set up procedure on page 25 in reverse.
7. Go to the main control panel HMI treater main screen. Press and hold the DOWN button on the drum actuator module and lower the drum until it stops, then insert the clevis pin back in the drum transport bracket.
8. Turn off the pump stand motors that are still running.
9. Turn off the power to the treater and Main Control Panels.
10. After all systems have been turned off, shutdown the generator by placing the main disconnect switch in the OFF position. Then press the red button once to shutdown the generator.

**SECTION
E**

TROUBLESHOOTING

TROUBLESHOOTING

Below is a table describing the most frequent problems and solutions with the Inlet and Outlet conveyors. For further assistance, contact the USC Service department at (785) 431-7900.

Problem	Possible Cause	Solution
Conveyor will not run.	<ol style="list-style-type: none"> 1. Not turned on. 2. Conveying belt loose. 3. Drive belt loose. 	<ol style="list-style-type: none"> 1. Start power source or turn on power. 2. Tighten and align belt. 3. Tighten drive belt.
Belt edge fraying.	<ol style="list-style-type: none"> 1. Belt not aligned. 	<ol style="list-style-type: none"> 1. Align and tension belt.
Low conveying capacity.	<ol style="list-style-type: none"> 1. Angle too steep. 2. Slow operating speed. 3. Conveyor belt slipping. 4. Drive belt slipping. 	<ol style="list-style-type: none"> 1. Reposition with angle at 30°. 2. Increase operating speed. 3. Tighten belt. 4. Set drive belt tension.
Discharge conveyor will not rotate right, left or raise up and down.	<ol style="list-style-type: none"> 1. Hydraulic line is leaking. 2. Not enough fluid in system. 3. Object is obstructing travel. 	<ol style="list-style-type: none"> 1. Repair or replace hose. 2. Check fluid level in reservoir. Add fluid. 3. Remove obstruction.
Treater E-Stops. Alarm message reads: "Drum Tilt Actuator NOT in requested position".	<ol style="list-style-type: none"> 1. Treater is positioned at an angle that is too steep because the trailer is not on level ground. The front or the back are too low. 2. Trailer can not be leveled at the current location 	<ol style="list-style-type: none"> 1. Level the trailer, then reset the system and continue to treat. 2. The treater inclinometer is based on true line of gravity. If the trailer can not be leveled. Log into the system as ADMIN and go to page 3 of the setpoints. Open up the angle tolerance. Plus or minus ten degrees is the maximum allowed. Refer to the U-Treat manual for more information.

PORTABLE LPV TREATER

UNPLUGGING

In unusual moisture or material conditions, the machine can plug. When unplugging, follow this procedure:

1. Place all controls in neutral or off, stop motor, disable and lock out power source before unplugging.
2. Remove the nut, bolt and sliding clean out door from the bottom of the inlet tube section of the conveyor. Remove any built up material. Reinstall door and hardware.



*Clean
Out
Doors*

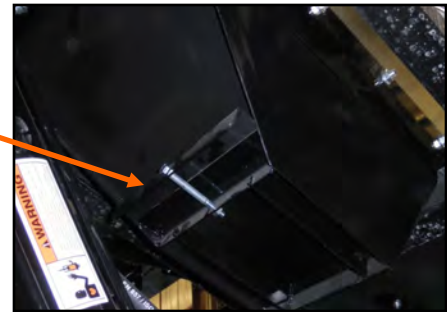

3. Open the tail cover (below).
4. Remove plugged material.
5. Install and secure conveyor and tail covers.

*Remove shipping bolts
after receiving
conveyor*

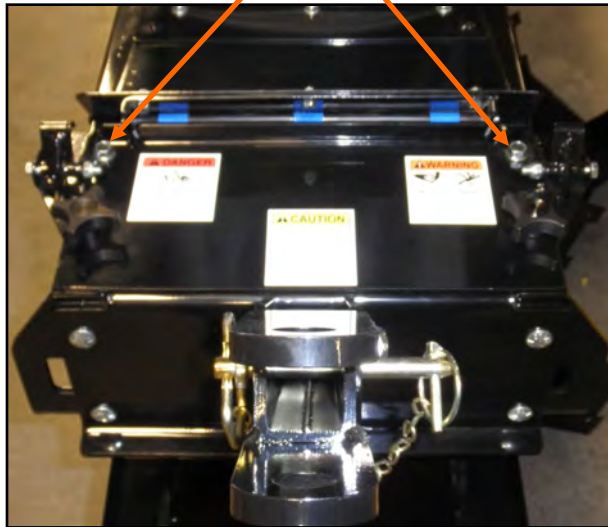

Bottom clean-out cover

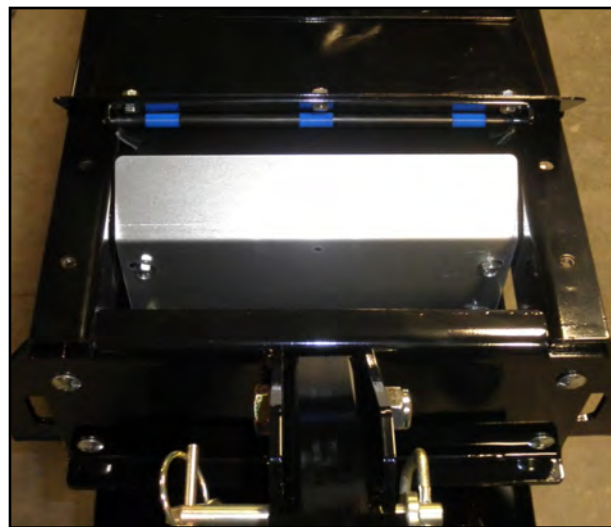

Bottom clean-out cover removed

**SECTION
F****MAINTENANCE**

Proper maintenance of the Portable LPV Treater is critical for peak performance, reliability and accuracy of this system. The following is a guideline for the type of maintenance and servicing that should be performed on this unit. Your environment and uses may require additional maintenance and service beyond this list to assure a reliable and safe unit. The operator of this unit has ultimate responsibility to identify areas of concern and rectify them before they become a hazard or safety issue. There is no substitute for a trained, alert operator.



Do not put this unit into operation with any questionably maintained parts. Poor performance or a hazard may occur.

ELECTRIC GENERATOR

If the portable treater is equipped with a Husker Power generator, refer to the Isuzu Diesel operators manual shipped in a box with all the other documentation.

FLUIDS AND LUBRICANTS**Grease**

Use an SAE multipurpose high temperature grease with extreme pressure (EP) performance. Also acceptable is an SAE multipurpose lithium-based grease.

Hydraulic Oil

Use DTE 25 hydraulic oil for Electric Powered Hydraulic Pack.

Storing Lubricants

Your machine can operate at top efficiency only if clean lubricants are used. Use clean containers to handle all lubricants. Store them in an area protected from dust, moisture and other contaminants.

GREASING

- Use a Maintenance Checklist to keep record of all scheduled maintenance.
- Use a hand-held grease gun for all greasing.
- Wipe grease fitting with a clean cloth before greasing to avoid injecting dirt and grit.
- Replace and repair broken fittings immediately.

NOTICE

If fittings will not take grease, remove and clean thoroughly. Also clean lubricant passageway. Replace fitting if necessary.

PORTABLE LPV TREATER
CONVEYOR SERVICING INTERVALS

Every 40 hours or Weekly

1. Check the conveyor belt tension and alignment.
2. Grease conveyor bearings.
 - A. Two bolt flanged bearings, tail roller bearings right and left (2 locations).
 - B. Two bolt flanged bearings, drive roller bearings right and left (2 locations).
3. Remove guard and check the drive belt tension and alignment. The belts will deflect approximately 1/4 to 1/2 inch when properly tensioned.

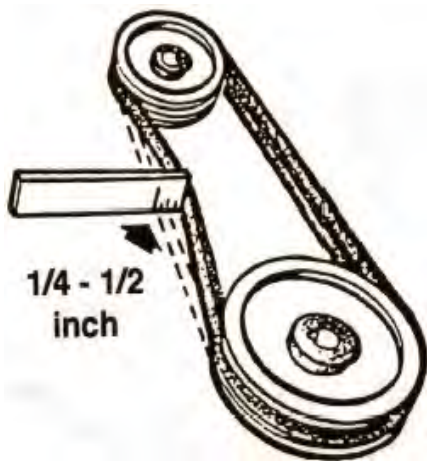

Every 200 hours or Annually

1. Repack wheel bearings.
2. Wash machine.
3. Check pulley bushing for wear. To inspect pulley:
 - A. Lower the conveyor to its lowest position.
 - B. When the conveyor has reached the lowest position, it will stop at the pins.
 - C. Loosen and remove the bolt.
 - D. Inspect the bushing on the pulley for wear.
 - E. Reverse steps A-E for re-assembly.

CONVEYING BELT TENSION AND ALIGNMENT-TAIL END

A contoured belt with molded flights is used to convey material along the frame. The tension and alignment of the belt should be checked weekly, or more often if required, to be sure that it does not slip or run to one side. A properly tensioned belt will not slip when it is operating. Operating the belt with less slippage will increase the belt life and causes less stress on bearings, pulleys and shafts.

▲ WARNING

Although it is acceptable to align the belt from either the Head or the Tail (Intake) end. Tightening the belt may only be done from the Tail end of the conveyor

To maintain the belt, follow this procedure:

NOTICE

Place all controls in neutral or off, stop motor and disable power source before working on belt.

1. Use the take-up bolt located at the tail to set the tension of the belting.
2. If the belt needs to be tightened to prevent slippage, use the take-up adjustments on the tail end only.
3. The belt is tightened by turning both take-up adjustments an **equal** number of turns.
4. Use the drive roller to check the alignment. The belt should be centered.
5. Turn the belt 1/2 revolution when the belt is new and check the drive and tail roller. If out of alignment, the belt will move to the loose side. Loosen the jam nut and use the bearing position bolts to set the position. Tighten jam nut.
6. Run and check again. Check frequently during the first few minutes of operation and then several times during the first 10 hours. The belt normally seats itself during the first 10 hours of operation and can be checked weekly after that.
7. The belt is properly aligned when the belt runs in the center of the head and tail rollers.

*Use this bolt to
tighten and
align the belt*

*Loosen these jam nuts before
adjusting the bearing position
bolt*

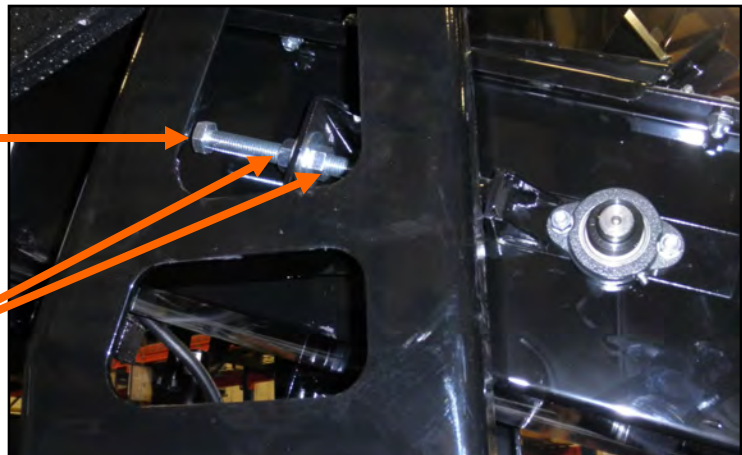

CONVEYING BELT ALIGNMENT - HEAD END

1. A misaligned belt will track toward the loose side. Set the tracking by loosening the bearing mounts on the tight side and using the bearing position bolt to move the end of the head roller toward the tail. Tighten the bearing mount when the belt is centered on the head roller.
2. Run the belt and check the tracking again. Loosen the tight side slightly again if required. Repeat the adjusting and checking procedure until the belt centers on the inlet end roller and remains centered when running.
3. Always repeat this aligning procedure when installing a new belt. Check frequently during the first 10 hours of operation. After 10 hours, the belt is normally seated and checking the alignment can be done less frequently.

*Tighten jam nuts
after adjustment*

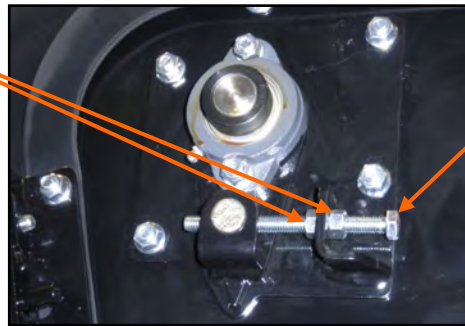

*Use this bolt to
align the belt*

BELT REPLACEMENT

1. Rotate the belt until the seam is visible.
2. Move the tail roller to its loosest position.
3. Pull all the slack to the seam area.
4. Remove the wire connector and open the belt.
5. Attach one end of the replacement belt to the belt end being removed.
6. Pull the old belt out and the new belt will be threaded into place.
7. Disconnect the old belt.
8. Connect the ends of the new belt together and secure.
9. Set the belt tension.
10. Check and set the belt alignment

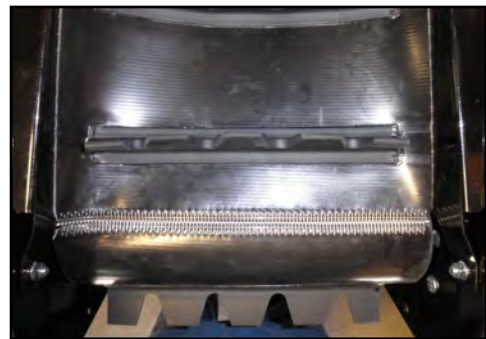

Belt Seam

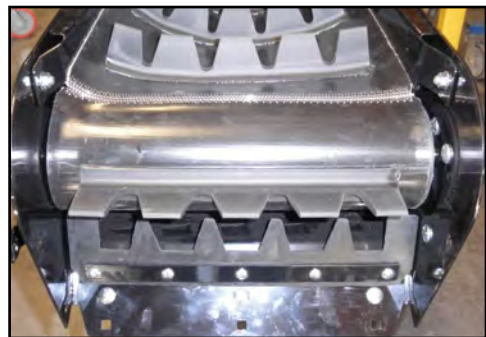

Check Alignment

DRIVE BELT TENSION & ALIGNMENT

Power to the conveying belt is transmitted through a V-belt. The V-belt drive system must be maintained at the proper belt tension and pulley alignment to obtain the desired performance and life. When maintaining the belt drive system for the electric drive model, follow this procedure:

NOTICE

Turn motor off and unplug power cord or turn off power and lock out the master panel before starting maintenance on drive belt system.

Drive Belt Tension

1. Push on the center of the belt span with a force of approximately 5 to 10 lbs.
2. Follow the belt tensioning specification on page 35 to determine proper belt deflection.
3. Move the motor up, using the adjustment bolt, to set drive belt tension (right).
4. Close and secure guards.

Drive Belt Alignment

1. Lay a straightedge across the pulley faces to check the alignment (right).
2. Use the pulley hub or the motor mounting plate slots to move the pulley to the required position for alignment.
3. Tighten hub bolts to secure pulley on shaft.
4. Check belt tension
5. Close and secure guards.

Drive Belt Replacement

1. Lower motor to its lowest position.
2. Remove old belt and replace with a new one.
3. Raise motor to set the belt tension.
4. Check pulley alignment. Adjust if required.
5. Close and secure guards.

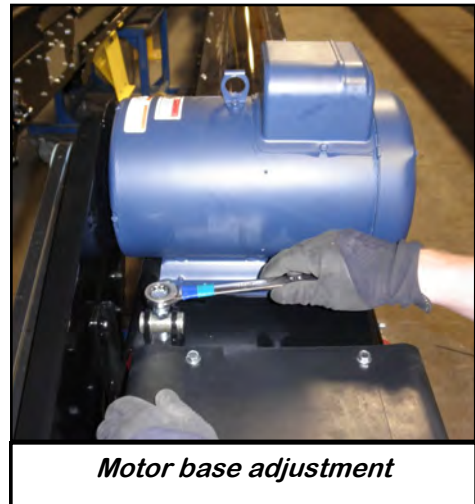

BELT TENSIONING SPECIFICATION

SECTION G

V-Belt tensioning adjustment can be made using a tension meter or other type spring scale using the following procedure. After seating the belts in the groove and adjusting center distance so as to take up the slack in the belts, further increase the tension until only a slight bow on the slack side is apparent while the drive is operating under load. Stop the drive and using the meter, measure the force necessary to depress one of the center belts 1/64 inch for every inch of belt span (see sketch below). For example, a deflection for a 50 inch belt span is 50/64 or 25/32 inch. The amount of force required to deflect the belt should compare with the deflection forces noted in the table below. Also notice for V- Belts that deflection forces vary from the initial RUN - IN values which are greater (reflecting higher run-in tensioning) to the NORMAL values for after the run-in period.

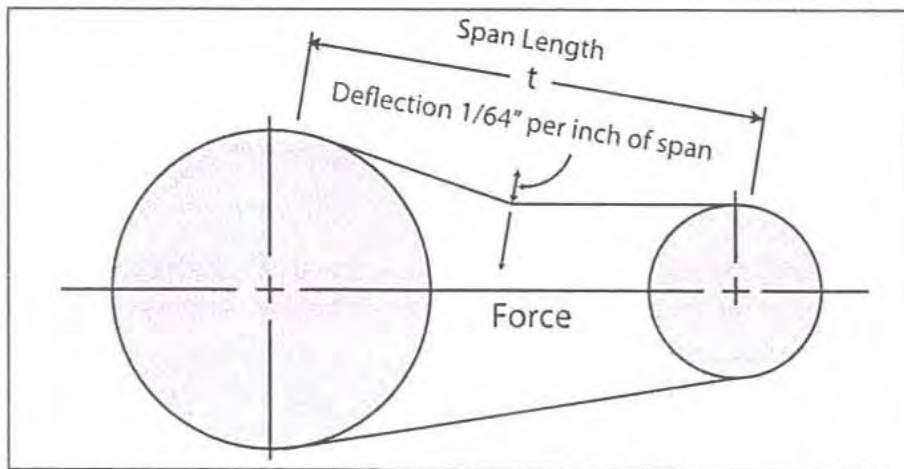

MEASURE THE SPAN LENGTH "T" AS SHOWN IN THE SKETCH ABOVE.

BELT CROSS SECTION	SMALLER PULLEY DIAMETER RANGE (inches)	DEFLECTION FORCE	
		RUN - IN (lbs)	NORMAL (lbs)
AX	3.0 - 3.6	4 - 1/8	2 - 3/4
	3.8 - 4.8	5	3 - 1/4
	5.0 - 7.0	6	4
BX	3.4 - 4.2	5 - 1/4	3 - 1/2
	4.4 - 5.2	7 - 1/8	4 - 3/4
	5.4 - 9.4	9	6

SECTION
H**STORAGE**

When storing the Portable LPV Treater for long periods of time, the following procedure must be followed to reduce the chance of rust, corrosion and fatigue of the conveyor. You can also use these steps when storing the machine for the winter.



A dust mask and protective rubber gloves shall be used when cleaning the machine.

1. Clear the area of bystanders, especially small children.
2. Thoroughly wash the entire machine to remove all dirt, mud, debris or residue.
3. Inspect all moving or rotating parts to see if anything has become entangled in them. Remove the entangled material.
4. Lubricate all grease fittings. Make sure that all grease cavities have been filled with grease to remove any water residue from the washing. This also protects the bearing seals.
5. Remove drive assembly cover. Clean entire area and ensure drive belt and chain are clean and free of debris. Lubricate drive chain.
6. Touch up all paint nicks and scratches to prevent rusting.
7. Select an area that is dry, level and free of debris.
8. If possible, store the machine inside a protective building to keep it from being exposed to the weather. If storing outside, cover the entire machine with a large waterproof tarpaulin. If you do not have one large enough, at a minimum cover all electric motors.
9. Unhook from towing vehicle.
10. Place blocks under the intake or the jack if required.
11. Store machine in an area away from human activity.
12. Do not allow children to play on or around the stored machine.

PORTABLE LPV TREATER

NOTES:

SECTION
I

MECHANICAL DRAWINGS

MANUAL TUBE ASSEMBLY (13-05-0322)

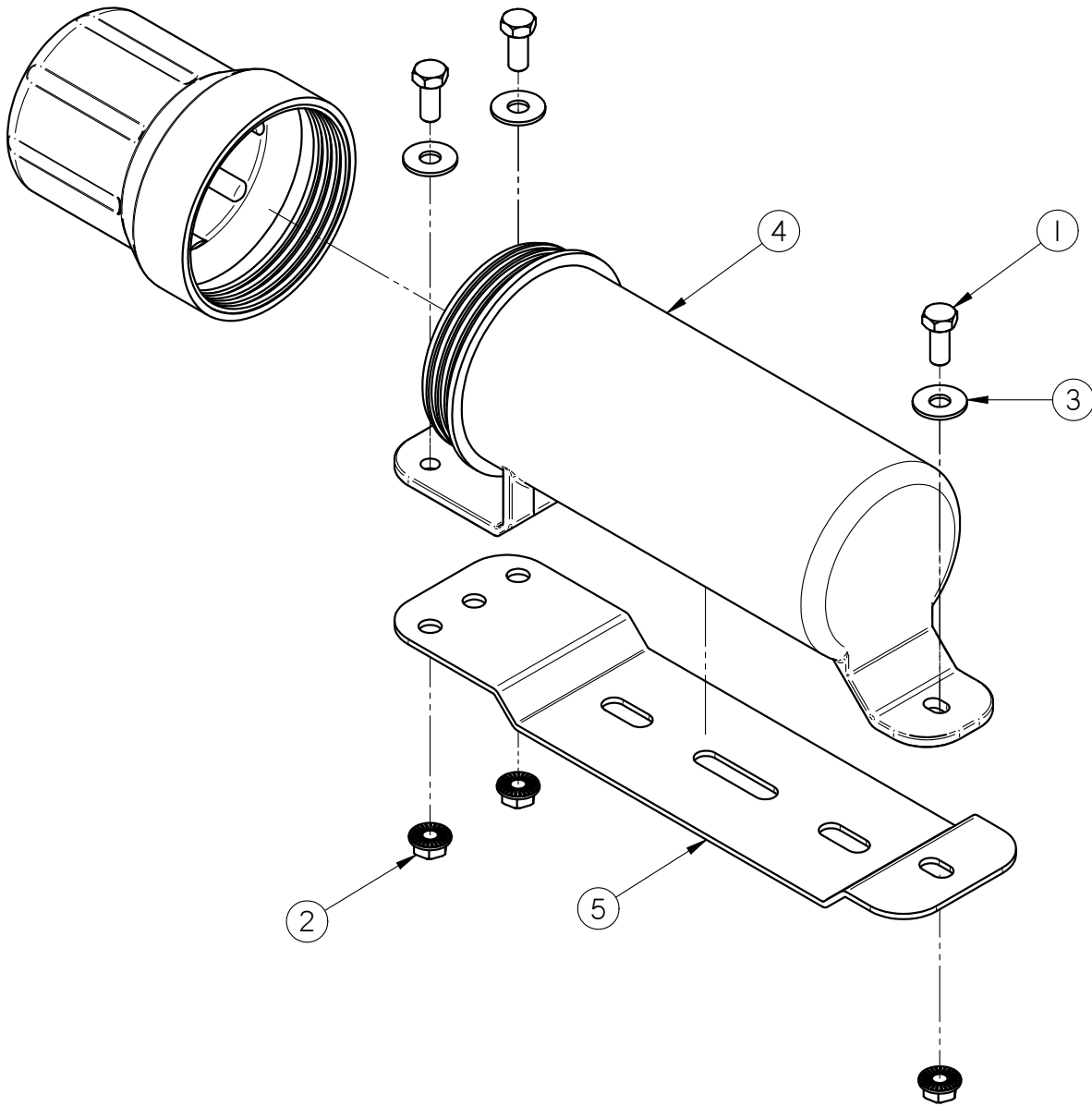

Item #	Part #	Description	Qty
1	06-01-0010	BOLT .313-18 X 0.75 ZP GR5	3
2	06-03-0019	NUT, FLG .3125-18 UNC ZP GRADE 5	3
3	06-05-0011	WASHER, .3125 FLAT 18-8 SS	3
4	08-07-0050	HOLDER MANUAL 3.25 DIA	1
5	103980	PLT MANUAL MT	1

PORTABLE LPV TREATER

ELECTRIC POWER PACK SWITCH ASSEMBLY (03-13-0037)

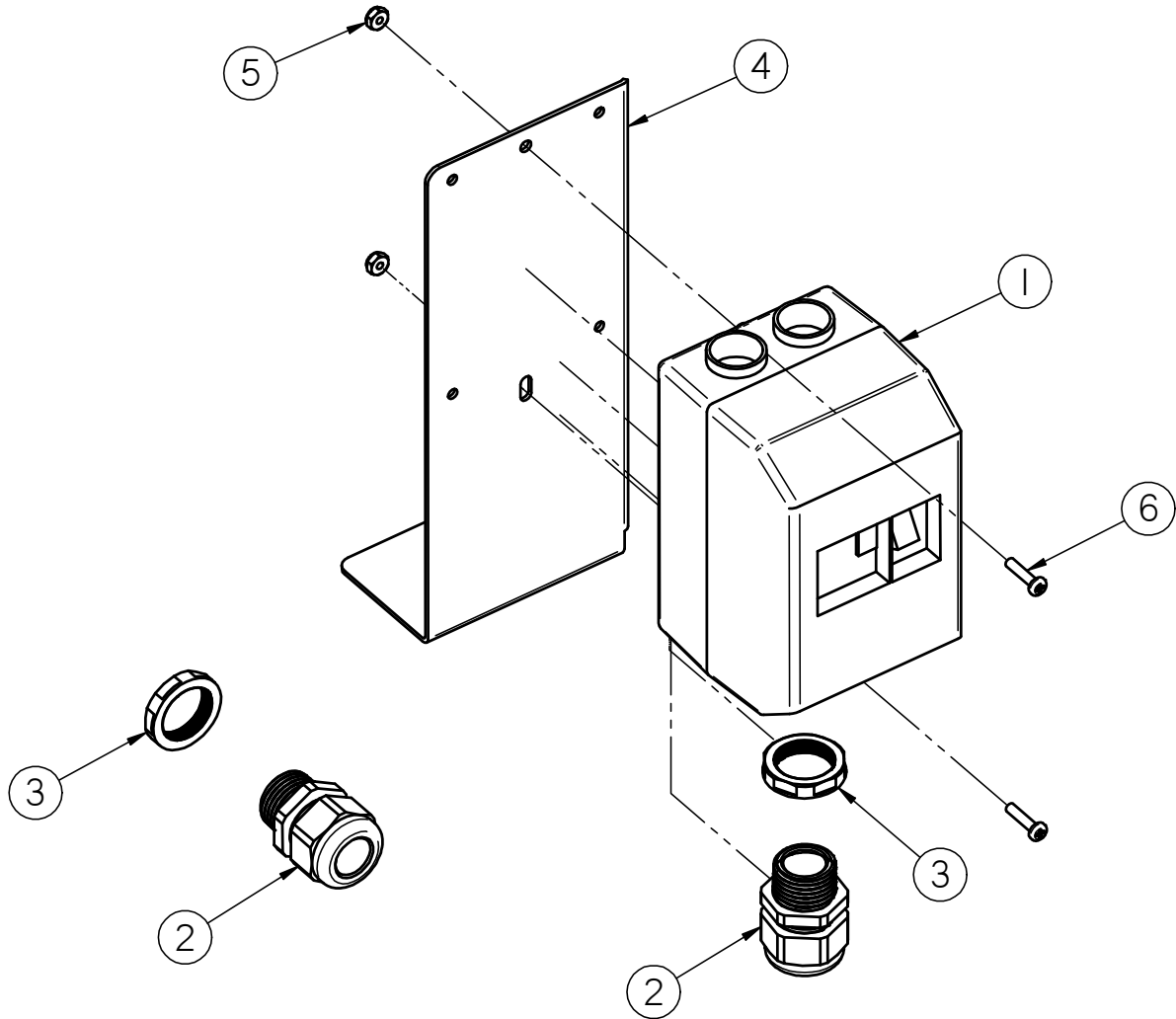

Item #	Part #	Description	Qty
1	03-04-0136	MP MNL 24-32A 600V TMQ GV2ME32	1
2	03-08-0300	CONN CG .75NPT .450-.709 3235LTF	2
3	03-08-0309	NUT NYLOC .750 NPT 8466	2
4	05-10-2002	BRKT SW MP ENCL	1
5	06-03-0017	NUT,LOCK, #8-32 ZP NYLON INSERT	2
6	06-06-0012	SCRW MACH 8-32 X .750 PHLP RDHD ZP	2

PORTABLE LPV TREATER

ELECTRIC POWER PACK ASSEMBLY (13-08-0721)

Item #	Part #	Description	Qty
1	01-01-0257	HYD PWR PK 2HP 1.0GPM 3000PSI	1
2	02-02-0125	VLV HYD 2 SPOOL 8GPM	1
3	02-05-0069	FTTG HYD STGHT 8MJ-8MOR	6
4	02-05-0074	FTTG HYD STGHT 8MJ-6MP	2
5	02-06-0059	FTTG HYD 90 DEG 8MJ-8FJX	8
6	03-13-0037	KIT SW MNL MP 110V 2 HP MTR 24-32A	1
7	06-01-0109	BOLT, .3125-18 UNC ZP G5; 2.25" LG	4
8	06-01-0116	BOLT .375-16 X 2.75 ZP GR5	2
9	06-01-0333	BOLT .3125-18 X 4.50 ZP GR5	3
10	06-03-0002	NUT NYL LOCK .313-18 ZP GR5	7
11	06-03-0003	NUT NYL LOCK .375-16 ZP GR5	2
12	06-03-0015	NUT LOCK FLG .500-13 ZP GR5	4
13	06-05-0003	WSHR FLAT .313 ZP	11
14	06-05-0004	WSHR FLAT .375 ZP	4
15	06-10-0025	EDGING SGRPG .375DP X .281W BLK	2
16	10564A	HOSE RETAINER	1
17	13-05-0335	HHA .375ID 090.0IN -08FJX -08FJX	1
18	13-05-0397	HHA .375ID 031.2IN -08FJX -08FJX	1
19	13-05-0412	HHA .375ID 034.6IN -08FJX -08FJX	2
20	13-05-0599	HHA .375ID 109.0IN -08FJX -08FJX	1
21	13-05-0601	HHA .375ID 054.0IN -08FJX -08FJX	1

PORTABLE LPV TREATER

5 HP MOTOR DIRECT DRIVE ASSEMBLY (13-05-0653)

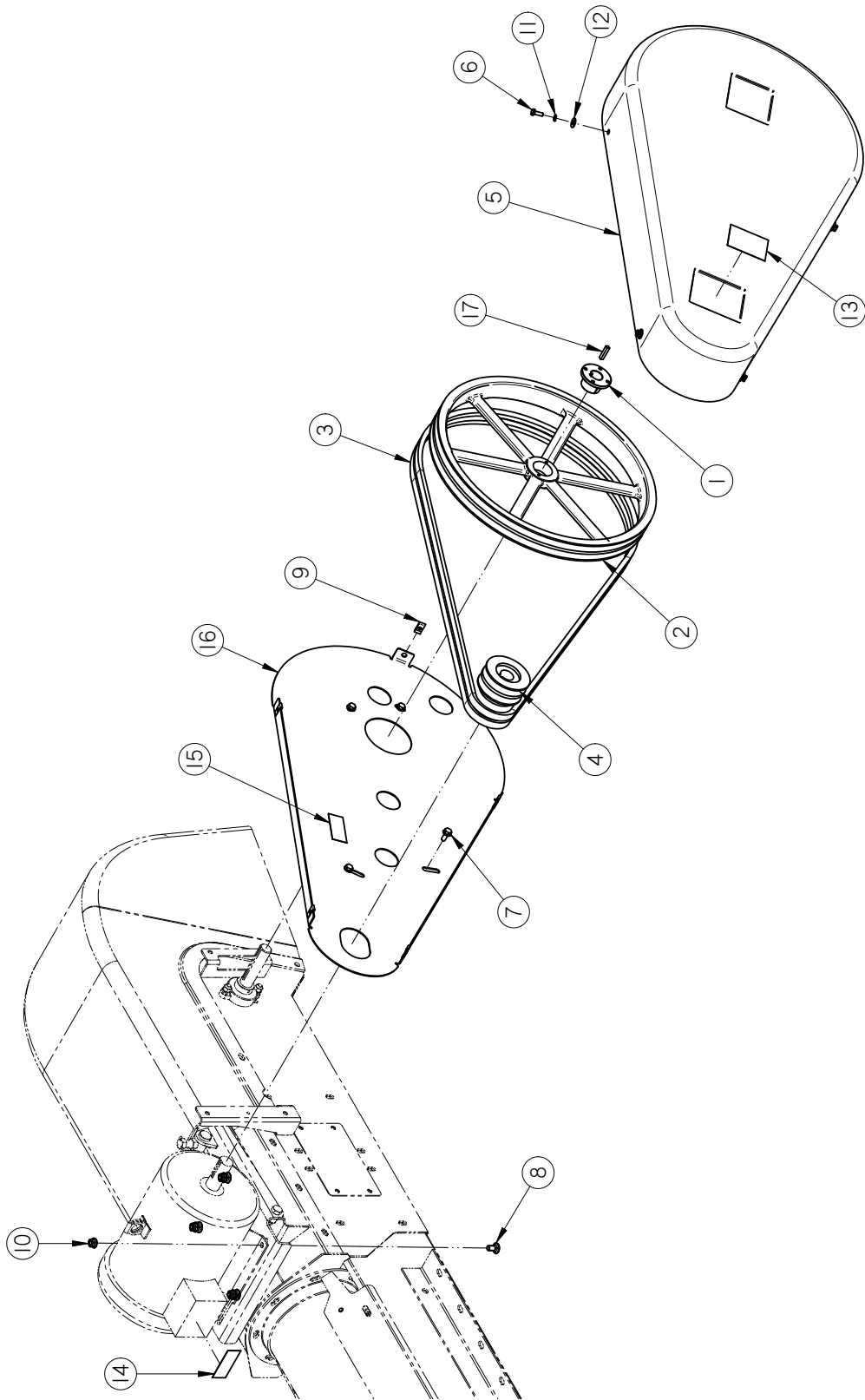

PORTABLE LPV TREATER

5 HP MOTOR DIRECT DRIVE ASSEMBLY (13-05-0653)

Item #	Part #	Description	Qty
1	01-02-0060	BUSH 1.000IN BORE TYPE H	1
2	01-08-0120	SHEAVE 2BK190H	1
3	01-08-0121	BELT BX88	2
4	01-08-0122	SHV 2BK36 X 1.125 FHSB BORE	1
5	05-06-0127	CVR BELT DRV	1
6	06-01-0006	BOLT, .250-20 X .75 UNC ZP GRADE 5	5
7	06-01-0138	BOLT, FLG .3125-18 UNC ZP GRADE 5; 3/4" LG	4
8	06-01-0153	BOLT CRG .375-16X.750 ZP SHORT NECK	4
9	06-02-0047	NUT .250-20 U-CLIP NUT	5
10	06-03-0014	NUT LOCK FLG .375-16 ZP GR5	4
11	06-04-0001	WSHR LOCK SPLT .250 ZP	4
12	06-05-0001	WASHER, FLAT .250	4
13	09-02-0009	ATWK LBL WARNING ROTATING PARTS	1
14	09-02-0010	ATWK LBL DANGER ELECTROCUTION	1
15	09-02-0012	ATWK LBL DANGER MISSING SHIELD	1
16	104869	BACKPLATE BELT COVER	1
17	106-3-2036	KEY .250 X 1.25 CS	1

PORTABLE LPV TREATER

LPV TREATER CONTAINMENT PAN ASSEMBLY (13-05-0609)

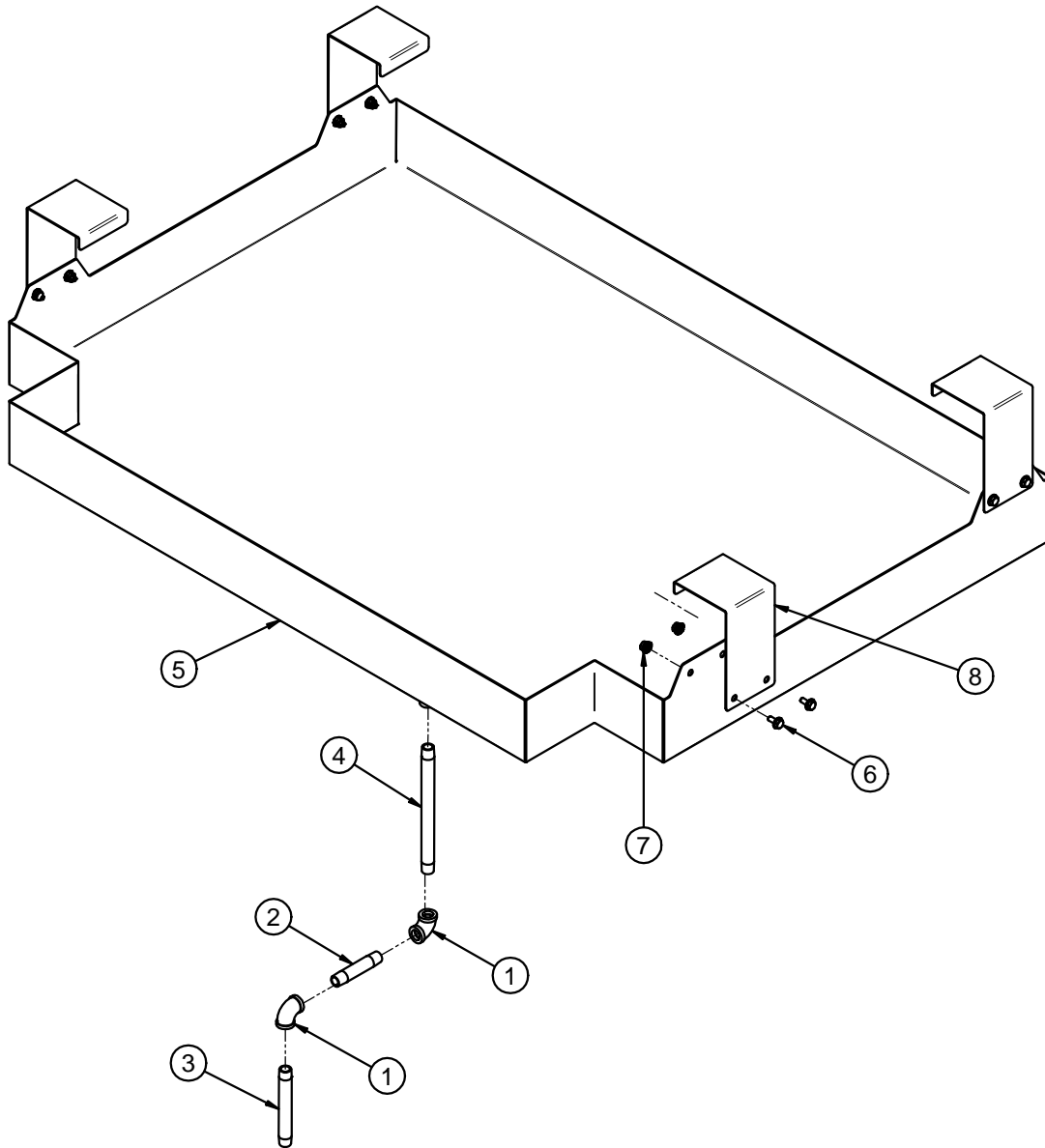

Item #	Part #	Description	Qty
1	02-06-0012	FTTG 90 DEG .500NPT FM SS	2
2	02-07-0013	FTTG NIP .500 NPT X 4.00 TBE SS	1
3	02-07-0015	FTTG NIP .500 NPT X 6.00 TBE SS	1
4	02-07-0058	FTTG NIP .500 NPT X 10.00 TBE SS	1
5	05-03-1711	WDMT LPV CONTAIN PAN	1
6	06-01-0124	BOLT FLG .375-16 X .750 ZP GR5	8
7	06-03-0014	NUT LOCK FLG .375-16 ZP GR5	8
8	10577A	MNT HANGER	4

PORTABLE LPV TREATER

PUMP STAND CONTAINMENT PAN ASSEMBLY (13-05-0610)

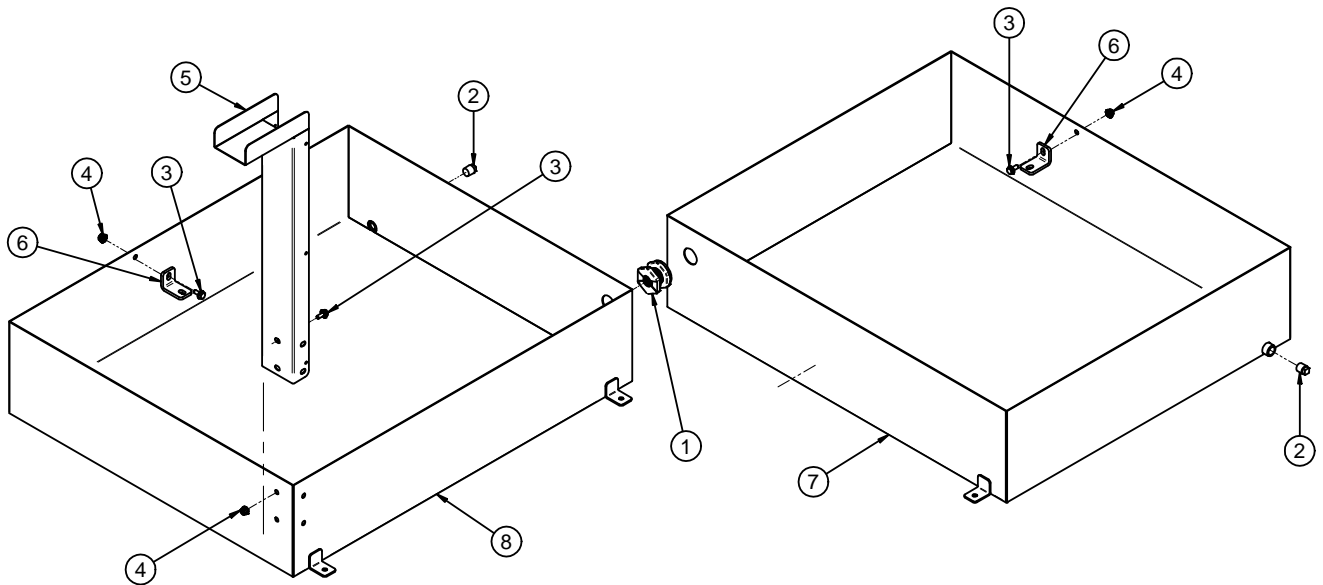

Item #	Part #	Description	Qty
1	02-05-0045	FTTG .750 NPT DBL THD PPE BULKHEAD	1
2	02-14-0001	FTTG PLUG SQHD .500 NPT SS	2
3	06-01-0124	BOLT FLG .375-16 X .750 ZP GR5	6
4	06-03-0014	NUT LOCK FLG .375-16 ZP GR5	6
5	105784	WDMT HOSE CONTAINMENT	1
6	105785	MNT BRKT	2
7	10578B	WDMT CONTAINMENT PAN	1
8	10578D	WDMT CONTAINMENT PAN	1

PORTABLE LPV TREATER
FOLD UP STEP ASSEMBLY (13-05-0592)

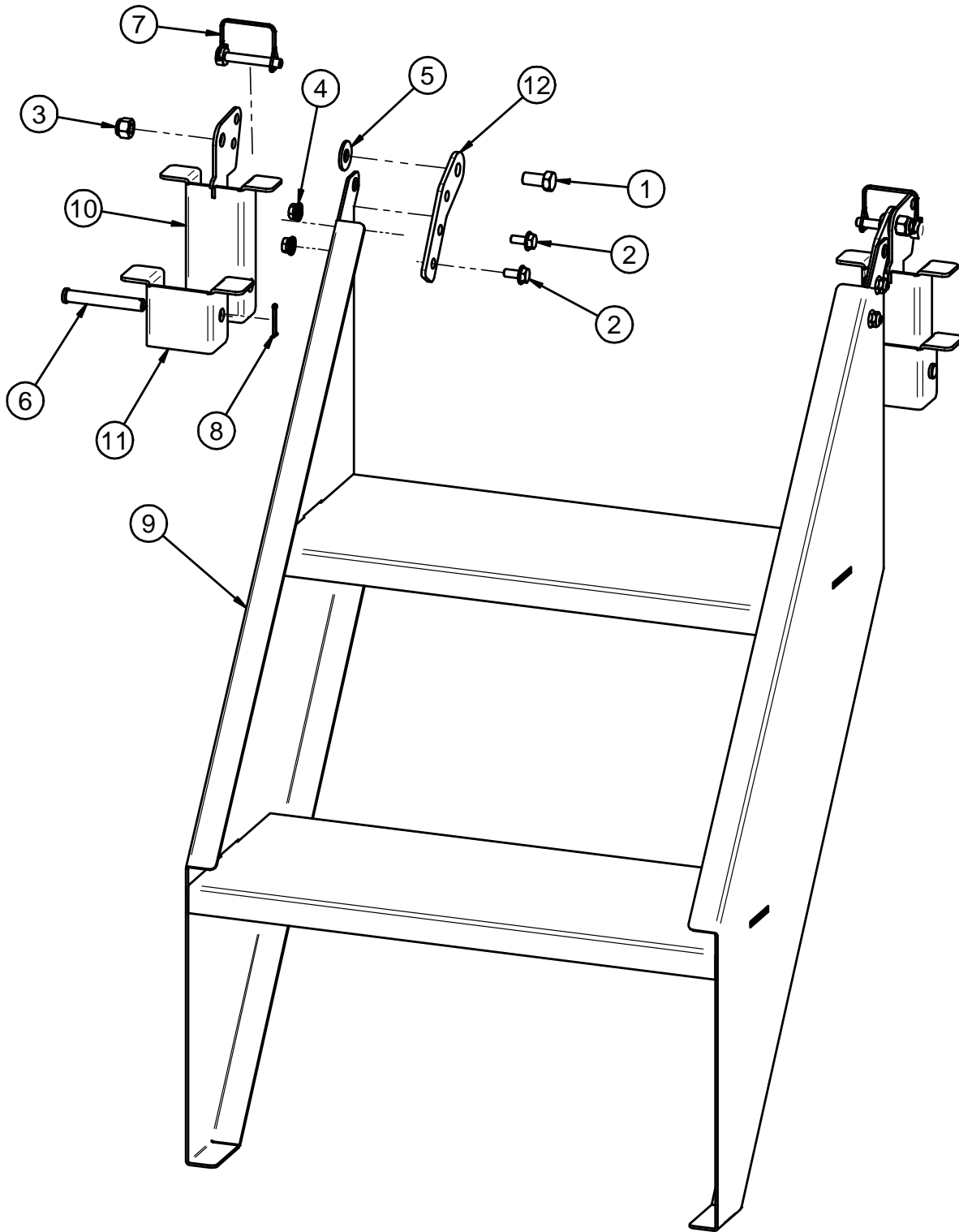

PORTABLE LPV TREATER
FOLD UP STEP ASSEMBLY (13-05-0592)

Item #	Part #	Description	Qty
1	06-01-0069	BOLT .500-13 X 1.00 ZP GR5	2
2	06-01-0124	BOLT FLG .375-16 X .750 ZP GR5	4
3	06-03-0004	NUT NYL LOCK .500-13 ZP GR5	2
4	06-03-0014	NUT LOCK FLG .375-16 ZP GR5	4
5	06-05-0005	WSHR FLAT .500 ZP	2
6	06-09-0005	PIN CLVS .500 X 3.50 PLN	2
7	06-09-0079	PIN SFTY .375 X 2.5 SQ DBL WIRE SNAP	2
8	06-09-0087	.125 X 1.50 ZP COTTER PIN	2
9	1055CD	WDMT PORT STEP	1
10	105702	WDMT HINGE	2
11	105740	BRKT HINGE LOCK	2
12	10574A	PLT HINGE ARM	2

PORTABLE LPV TREATER

TREATER INLET HOPPER EXTENSION ASSEMBLY (10550E)

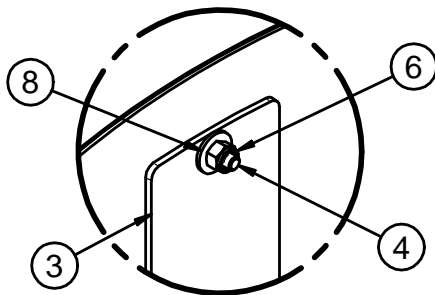
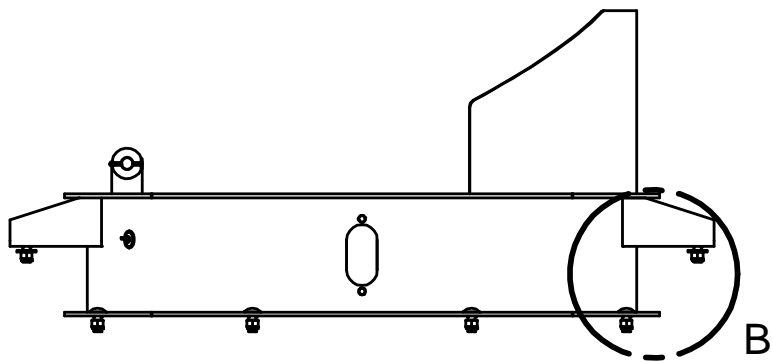
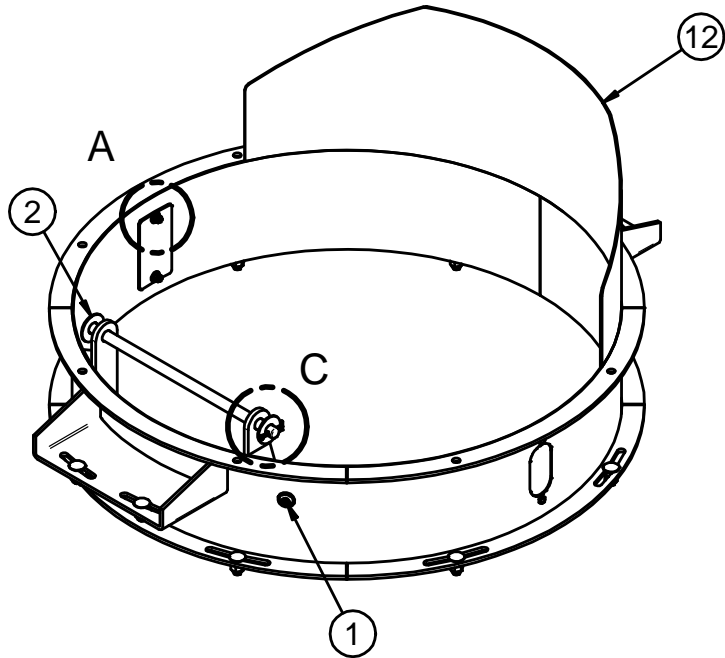

DETAIL A

PORTABLE LPV TREATER

TREATER INLET HOPPER EXTENSION ASSEMBLY (10550E)

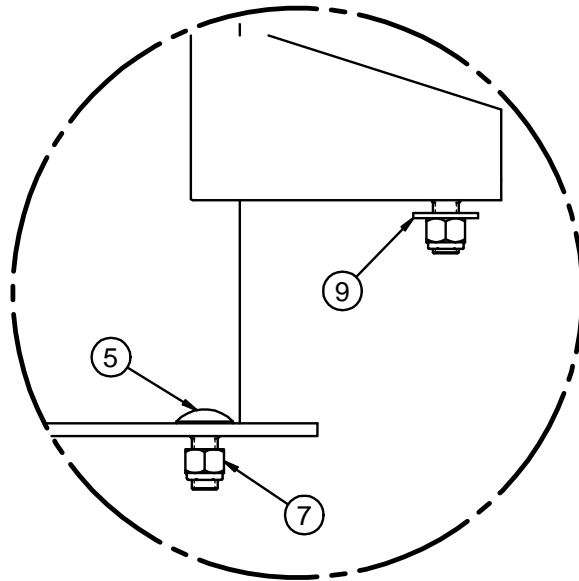

DETAIL B

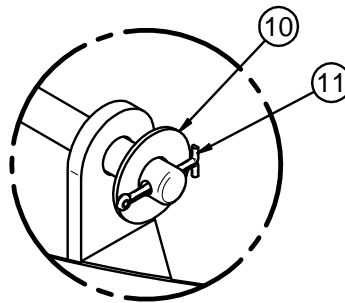

DETAIL C

Item #	Part #	Description	Qty
1	03-08-0130	PLUG STEEL 22MM	1
2	05-04-0016	WDMT FRONT PIVOT ROD	1
3	05-10-4064	PLT HOPP 6IN EXT VIEW	2
4	06-01-0006	BOLT, .250-20 X .75 UNC ZP GRADE 5	4
5	06-01-0062	BOLT CRG .500-13 X 1.25 ZP GR5	12
6	06-03-0001	NUT,LOCK, .250-20 ZP G5 NYLON INSERT	4
7	06-03-0004	NUT NYL LOCK .500-13 ZP GR5	12
8	06-05-0001	WASHER, FLAT .250	4
9	06-05-0005	WSHR FLAT .500 ZP	4
10	06-05-0007	WASHER, .750 FLAT ZP	1
11	06-09-0023	.188 X 2.00 ZP COTTER PIN	1
12	105510	WDMT 36ID X 8 INLET HOPP EXT CS	1

OUTLET CONVEYOR REST ASSEMBLY (13-05-0622)

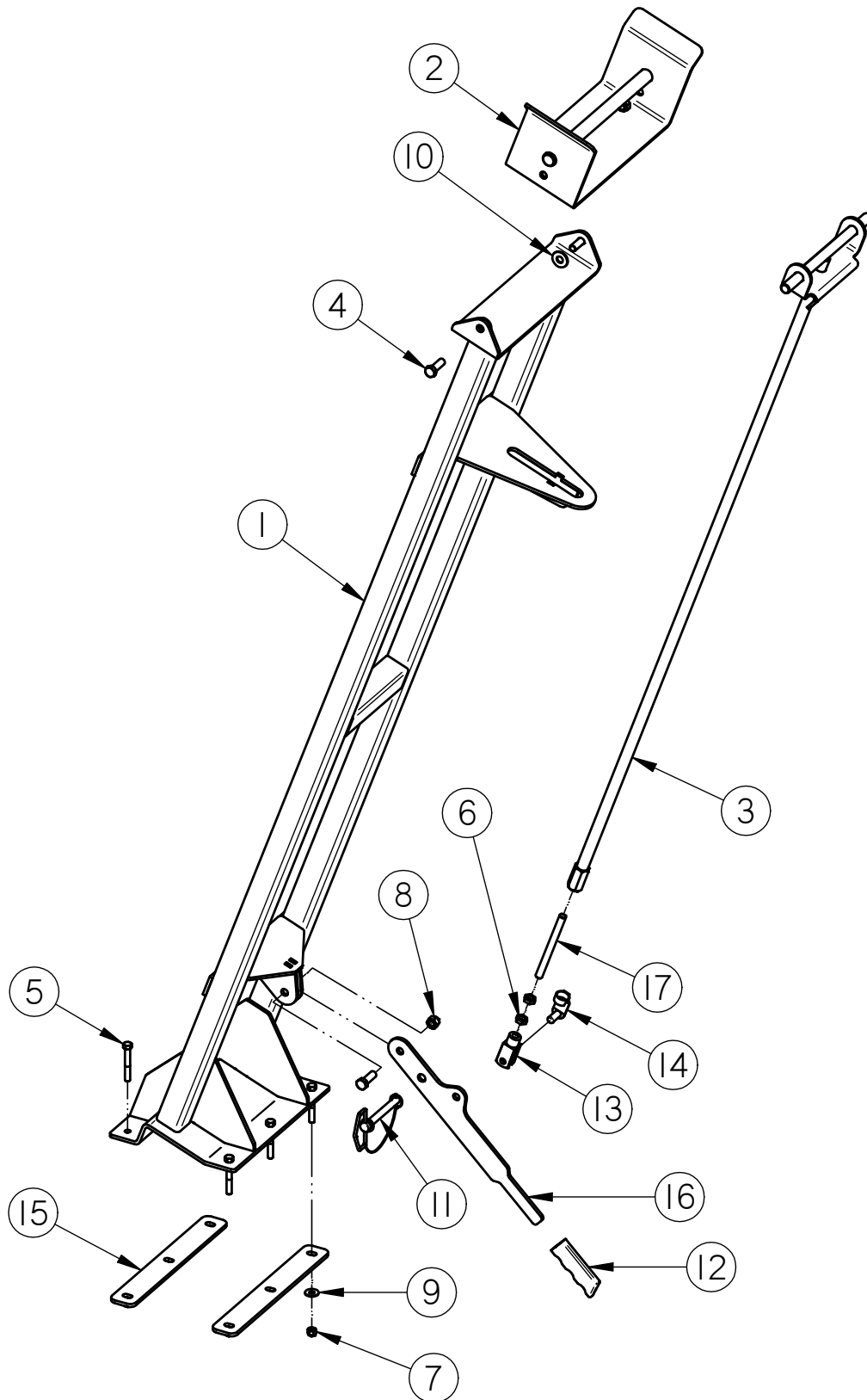

PORTABLE LPV TREATER

OUTLET CONVEYOR REST ASSEMBLY (13-05-0622)

Item #	Part #	Description	Qty
1	05-03-1718	WDMT CNVR REST W/LK PORT	1
2	05-03-1719	WDMT CNVR REST W/LK PIVOT	1
3	05-03-1720	WDMT LATCH ROD	1
4	06-01-0025	BOLT .500-13 X 1.50 ZP GR5	3
5	06-01-0116	BOLT .375-16 X 2.75 ZP GR5	6
6	06-02-0015	NUT JAM .500-20 ZP GR5	2
7	06-03-0003	NUT NYL LOCK .375-16 ZP GR5	6
8	06-03-0004	NUT NYL LOCK .500-13 ZP GR5	3
9	06-05-0004	WSHR FLAT .375 ZP	6
10	06-05-0005	WSHR FLAT .500 ZP	2
11	06-09-0053	PIN HITCH .500 X 4.0 LG W-LINCH PIN	1
12	06-09-0085	CLPSBL HOPP HNDL GRIP	1
13	06-12-0008	CLVS .500-20 X .500	1
14	06-12-0009	PIN CLIP SPRING .500	1
15	105748	PLT BACKING CNVR REST	2
16	1058EE	PLT LEVER LOCK	1
17	1059D4	ROD FTH .500-20 X 6.00	1

PORTABLE LPV TREATER
CONVEYOR PIVOT ASSEMBLY (13-05-0594)

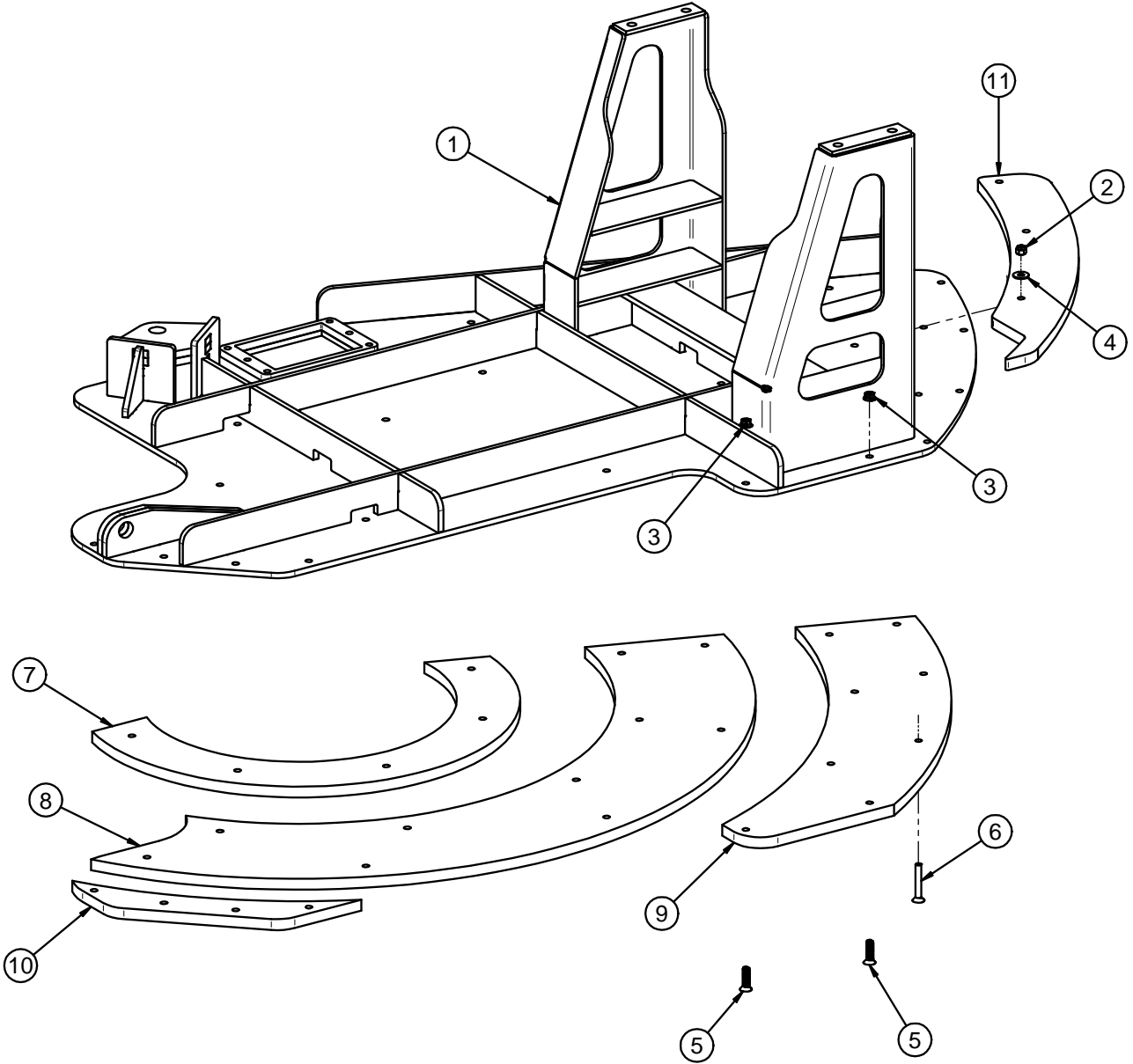

PORTABLE LPV TREATER
CONVEYOR PIVOT ASSEMBLY (13-05-0594)

Item #	Part #	Description	Qty
1	05-03-1691	WDMT PIVOT PLT	1
2	06-03-0003	NUT NYL LOCK .375-16 ZP GR5	3
3	06-03-0014	NUT LOCK FLG .375-16 ZP GR5	24
4	06-05-0004	WSHR FLAT .375 ZP	3
5	06-06-0070	SCRW MACH .375-16 X 1.50 SH FLHD BO	24
6	06-06-0107	SCRW MACH .375-16 X 2.50 SH FLHD BO	3
7	1054FC	PIVOT PLT BTM SLIDE 1	1
8	1054FD	PIVOT PLT BTM SLIDE 2	1
9	1054FE	PIVOT PLT BTM SLIDE 3	1
10	1055AC	PIVOT PLT BTM SLIDE 4	1
11	1059D5	PIVOT PLT TOP SLIDE	1

PORTABLE LPV TREATER
LPV PORTABLE PIVOT ASSEMBLY (13-05-0594)

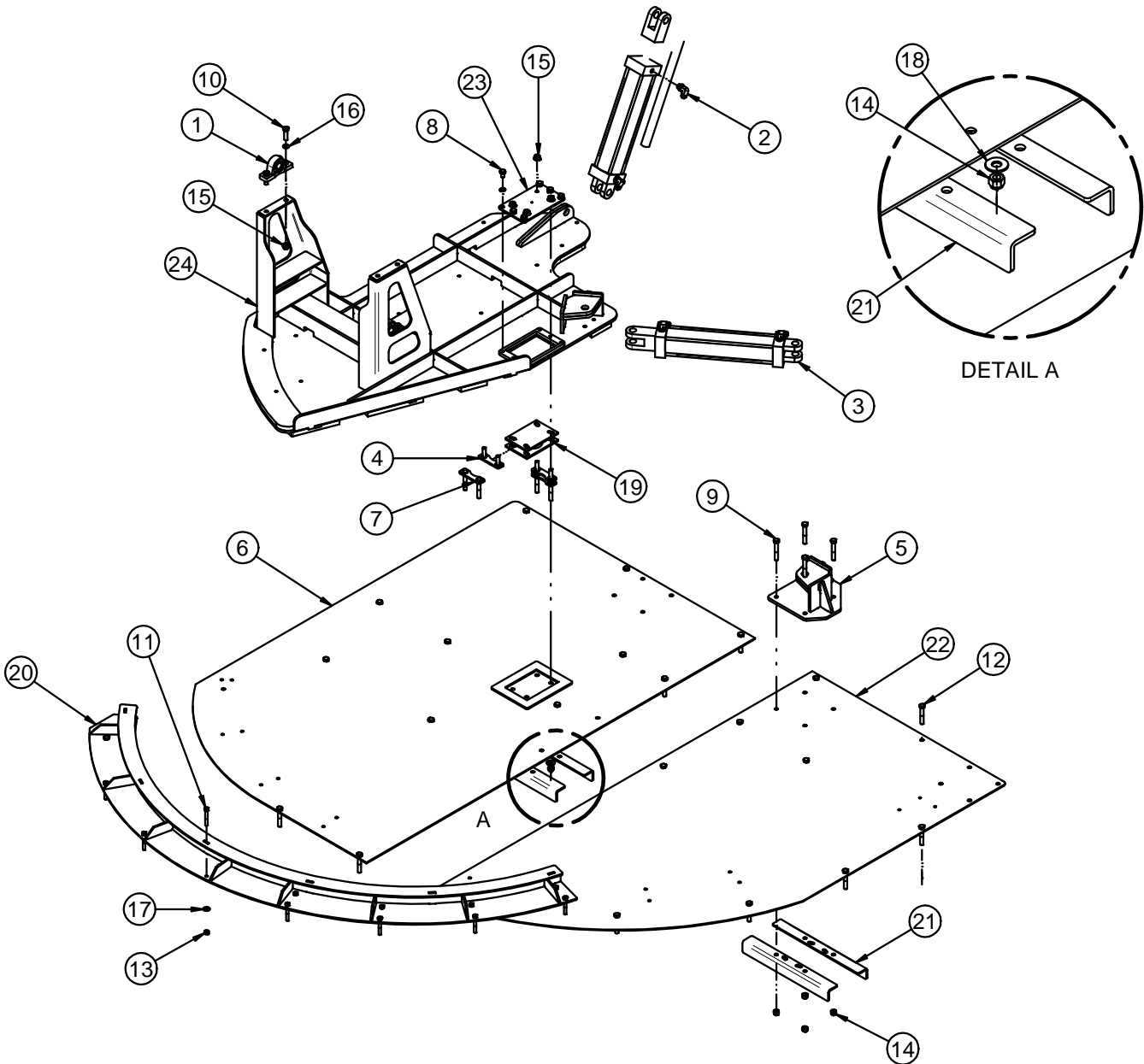

PORTABLE LPV TREATER

LPV PORTABLE PIVOT ASSEMBLY (13-05-0594)

Item #	Part #	Description	Qty
1	01-03-0060	BRG PLW SEALED 1.00ID STSC	2
2	02-06-0058	FTTG HYD 90 DEG 8MJ-8MOR	4
3	03-17-0133	CYL HYD 14IN STRK 3.0IN ID	2
4	05-03-1706	WDMT BOLT HLDR	2
5	05-03-1708	WDMT CYLN MNT LPV PORT	1
6	05-03-1709	WDMT DECK PLT TURNTABLE	1
7	05-03-1710	WDMT BOLT HLDR LG	2
8	06-01-0024	BOLT .500-13 X .750 ZP GR5	6
9	06-01-0029	BOLT .500-13 X 3.25 ZP GR5	4
10	06-01-0054	BOLT .500-13 X 1.75 ZP GR5	4
11	06-01-0116	BOLT .375-16 X 2.75 ZP GR5	16
12	06-01-0252	BOLT .500-13 X 3.00 ZP GR5	24
13	06-03-0003	NUT NYL LOCK .375-16 ZP GR5	16
14	06-03-0004	NUT NYL LOCK .500-13 ZP GR5	32
15	06-03-0015	NUT LOCK FLG .500-13 ZP GR5	8
16	06-04-0004	WSHR LOCK SPLT .500 ZP	10
17	06-05-0004	WSHR FLAT .375 ZP	16
18	06-05-0005	WSHR FLAT .500 ZP	6
19	06-08-0007	TURNTABLE 1500LB	1
20	105516	WDMT PIVOT RETAINER	1
21	105726	PIVOT SUPPT BRKT	4
22	105752	PLT LPV PORT PIVOT	1
23	10575A	PLT PIVOT MNT	1
24	13-05-0586	ASSY CNVR PIVOT PLT	1

PORTABLE LPV TREATER

INLET CONVEYOR INLET HOPPER ASSEMBLY (13-08-0540)

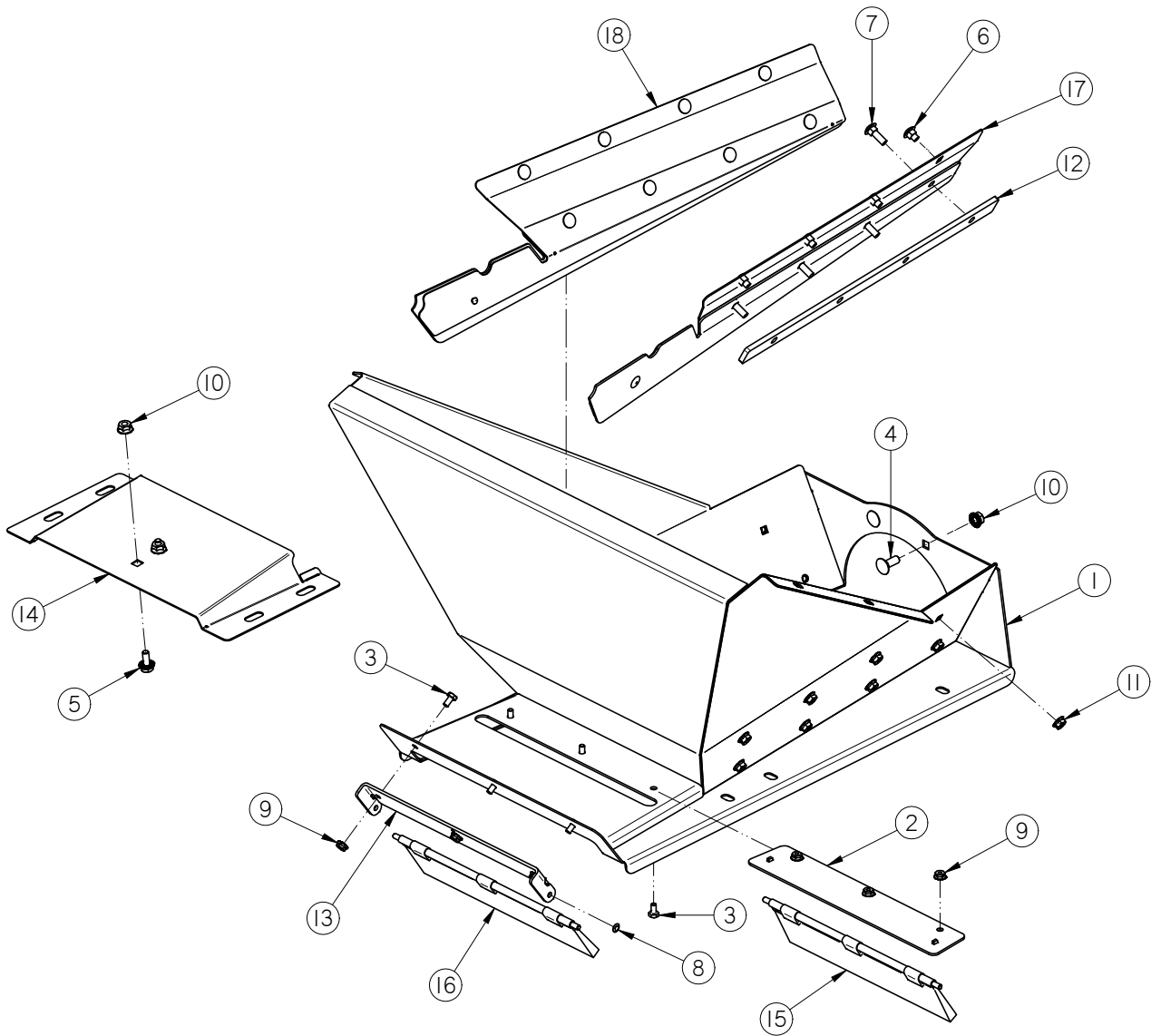

PORTABLE LPV TREATER

INLET CONVEYOR INLET HOPPER ASSEMBLY (13-08-0540)

Item #	Part #	Description	Qty
1	05-08-0477	WDMT LG INLET 8IN RND	1
2	05-08-0536	WDMT PIVOT BRSH PLT TS25	1
3	06-01-0004	BOLT, .250-20 X .500 UNC ZP GRADE 5	6
4	06-01-0115	BOLT CRG .375-16 X 1.00 ZP GR5	2
5	06-01-0124	BOLT FLG .375-16 X .750 ZP GR5	2
6	06-01-0129	BOLT CRG .313-18 X .50 ZP GR5	8
7	06-01-0223	BOLT CRG .313-18 X 1.00 ZP GR5	8
8	06-02-0100	PUSH NUT SS .250 UNTHREADED	2
9	06-03-0013	NUT,LOCK, FLG .250-20 ZP SERRATED	6
10	06-03-0014	NUT LOCK FLG .375-16 ZP GR5	4
11	06-03-0019	NUT LOCK FLG .3125-18 ZP GR5	16
12	103D17	PLT SKIRT SPACER	2
13	10472A	EAR BRUSH MNT	1
14	105608	COVER CLN\OUT	1
15	13-05-0478	ASSY BRUSH W\CLIPS 11.25	1
16	13-05-0479	ASSY BRUSH W\CLIPS 11.88	1
17	13-05-0582	ASSY SKIRT RH TS25	1
18	13-05-0583	ASSY SKIRT RIGID TS25	1

PORTABLE LPV TREATER

INLET CONVEYOR INLET END ASSEMBLY (13-08-0532)

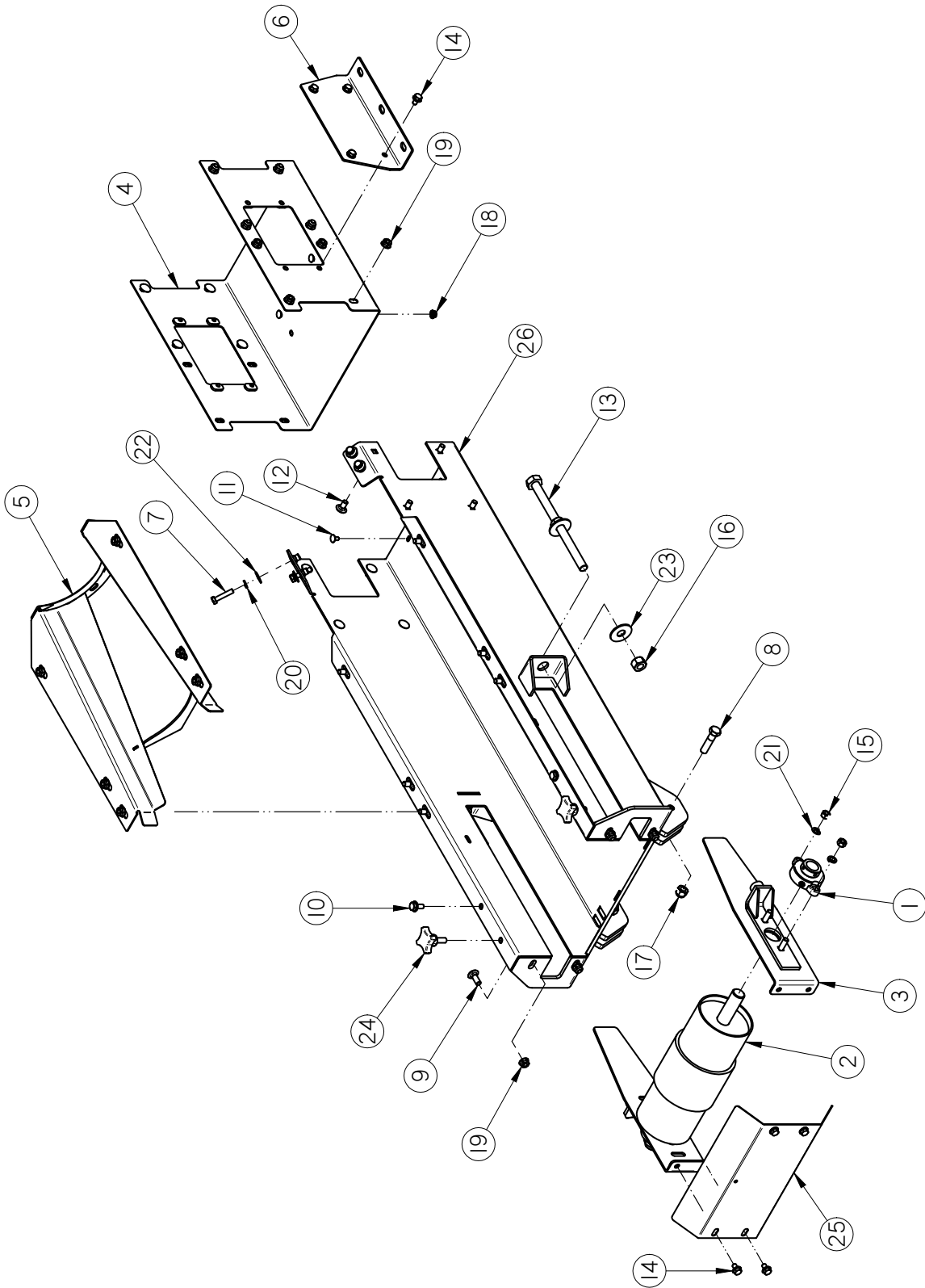

PORTABLE LPV TREATER

INLET CONVEYOR INLET END ASSEMBLY (13-08-0532)

Item #	Part #	Description	Qty
1	01-03-0042	BRG FLG MNT 1.000ID 2BOLT ECNTRC	2
2	01-08-0108	PULLEY TAIL W-LAGGING	1
3	05-08-0404	WDMT TAKE-UP PLT RND CNVR	2
4	05-08-0419	WDMT SPLICE 12IN	1
5	05-08-0569	WDMT TAIL TRANS TS25	1
6	05-10-4339	PLT STOP MOUNT	2
7	06-01-0013	BOLT, .312-18 UNC ZP GRADE 5; 1.50" LG	4
8	06-01-0027	BOLT .500-13 X 2.00 ZP GR5	2
9	06-01-0115	BOLT CRG .375-16 X 1.00 ZP GR5	4
10	06-01-0124	BOLT FLG .375-16 X .750 ZP GR5	2
11	06-01-0150	BOLT, CARRIAGE, .250-20x.50 G5 ZP	4
12	06-01-0153	BOLT CRG .375-16X.750 ZP SHORT NECK	22
13	06-01-0249	BOLT .625-11 X 9.00 ZP GR5 FTH	2
14	06-01-0261	BOLT FLG .3125-18 X .500 ZP GR5	12
15	06-02-0003	NUT FULL .375-16 ZP GR5	4
16	06-02-0005	NUT, .625-11 UNC ZP GRADE 5	4
17	06-03-0004	NUT NYL LOCK .500-13 ZP GR5	2
18	06-03-0013	NUT,LOCK, FLG .250-20 ZP SERRATTED	4
19	06-03-0014	NUT LOCK FLG .375-16 ZP GR5	28
20	06-04-0002	WSHR LOCK SPLT .313 ZP	4
21	06-04-0003	WSHR LOCK SPLT .375 ZP	4
22	06-05-0003	WSHR FLAT .313 ZP	4
23	06-05-0006	WASHER, .625 FLAT ZP	4
24	06-09-0066	KNOB .375 -16 X 1. 4 LUG PLASTIC	2
25	104241	PLT TAKE-UP CVR	1
26	13-05-0523	ASSY INLET FRAME W/RIVETNUTS TS25	1

PORTABLE LPV TREATER

INLET CONVEYOR EXTENSION CLEAN OUT ASSEMBLY (13-08-0668)

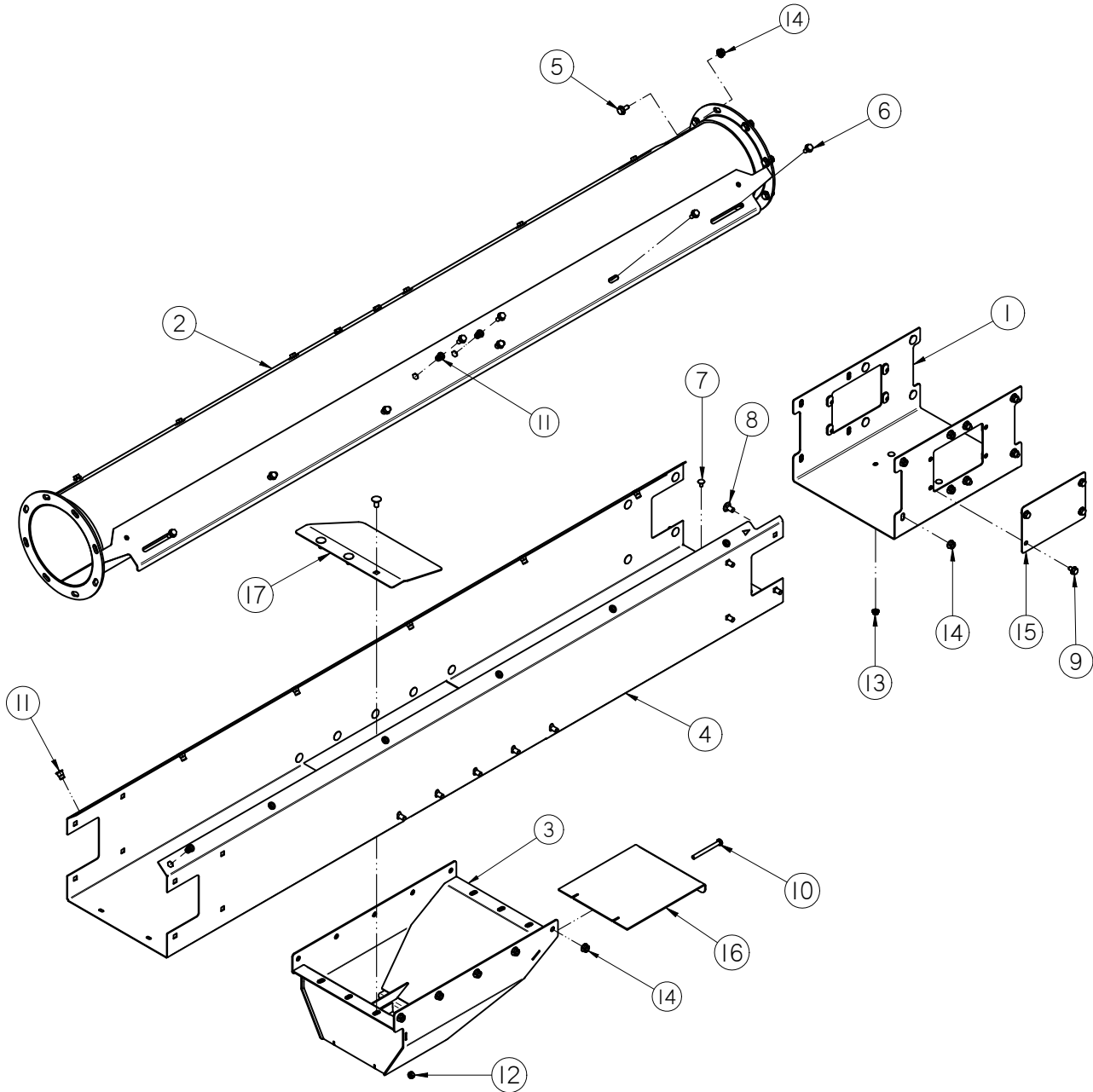

PORTABLE LPV TREATER

INLET CONVEYOR EXTENSION CLEAN OUT ASSEMBLY (13-08-0668)

Item #	Part #	Description	Qty
1	05-08-0419	WDMT SPLICE 12IN	1
2	05-08-0461	WDMT TUBE 8.00IN X 84.86IN	1
3	05-08-0610	WDMT CLEAN OUT	1
4	05-10-4524	FRAME INLET SEC CLN OUT	1
5	06-01-0124	BOLT FLG .375-16 X .750 ZP GR5	8
6	06-01-0138	BOLT, FLG .3125-18 UNC ZP GRADE 5; 3/4" LG	16
7	06-01-0150	BOLT, CARRIAGE, .250-20x.50 G5 ZP	4
8	06-01-0153	BOLT CRG .375-16X.750 ZP SHORT NECK	32
9	06-01-0261	BOLT FLG .3125-18 X .500 ZP GR5	8
10	06-01-0311	BOLT .313-18 X 3.25 ZP GR5	1
11	06-02-0092	RIVETNUT .312-18 ZP	16
12	06-03-0002	NUT NYL LOCK .313-18 ZP GR5	1
13	06-03-0013	NUT,LOCK, FLG .250-20 ZP SERRATED	4
14	06-03-0014	NUT LOCK FLG .375-16 ZP GR5	40
15	103B9A	PLT SPLICE COVER	2
16	1050CF	PLT DOOR CLEAN OUT	1
17	1050E8	PLT BELT GUIDE	1

PORTABLE LPV TREATER

ADJUSTABLE DISCHARGE SPOUT ASSEMBLY (13-08-0705)

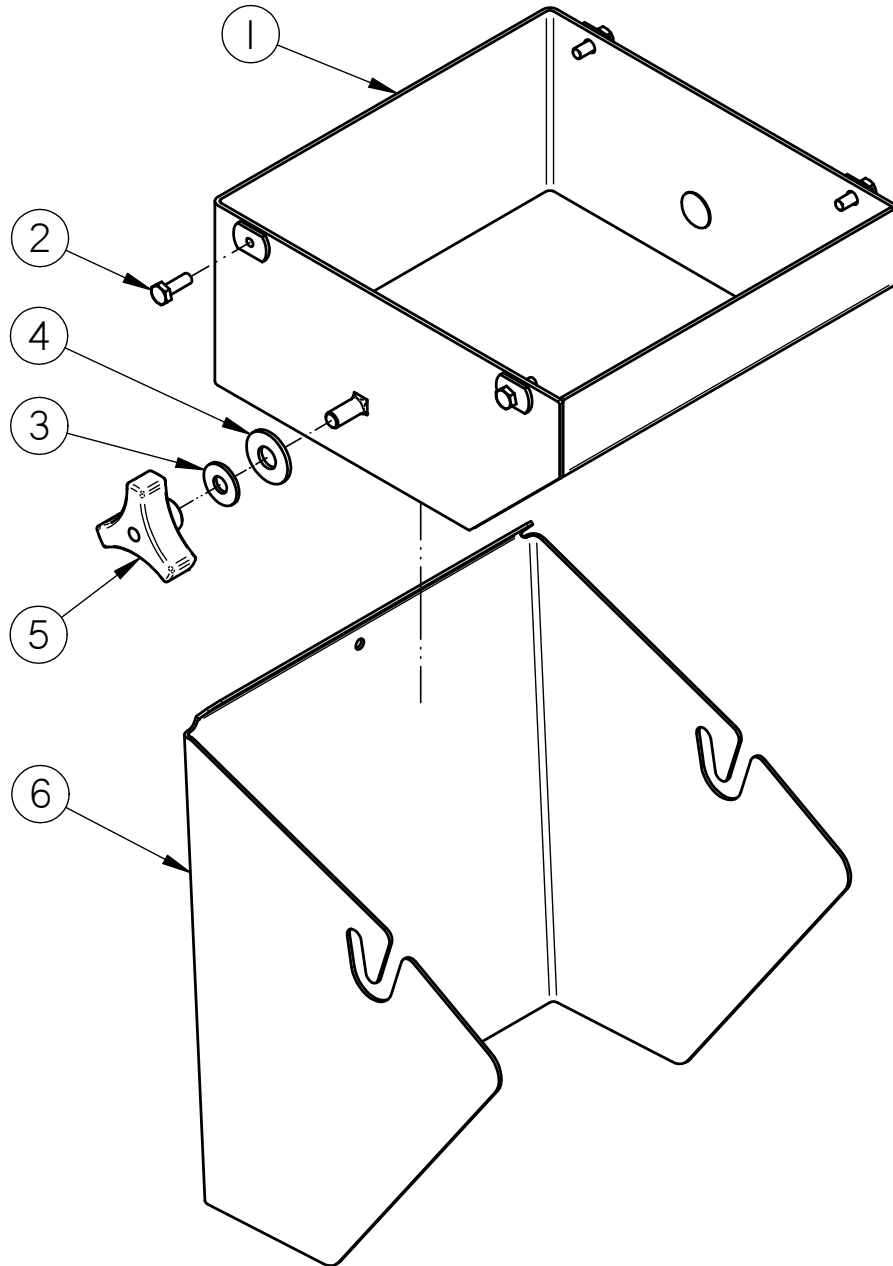

Item #	Part #	Description	Qty
1	05-08-0661	WDMT SPOUT MNT	1
2	06-01-0006	BOLT .250-20 X .750 ZP GR5	4
3	06-05-0004	WSHR FLAT .375 ZP	2
4	06-05-0005	WSHR FLAT .500 ZP	2
5	06-09-0001	KNOB 3PRONG 1.25IN	2
6	105429	PLT ADJ SPOUT	1

PORTABLE LPV TREATER

HEAD TRACKING PLATE ASSEMBLY (13-08-0564)

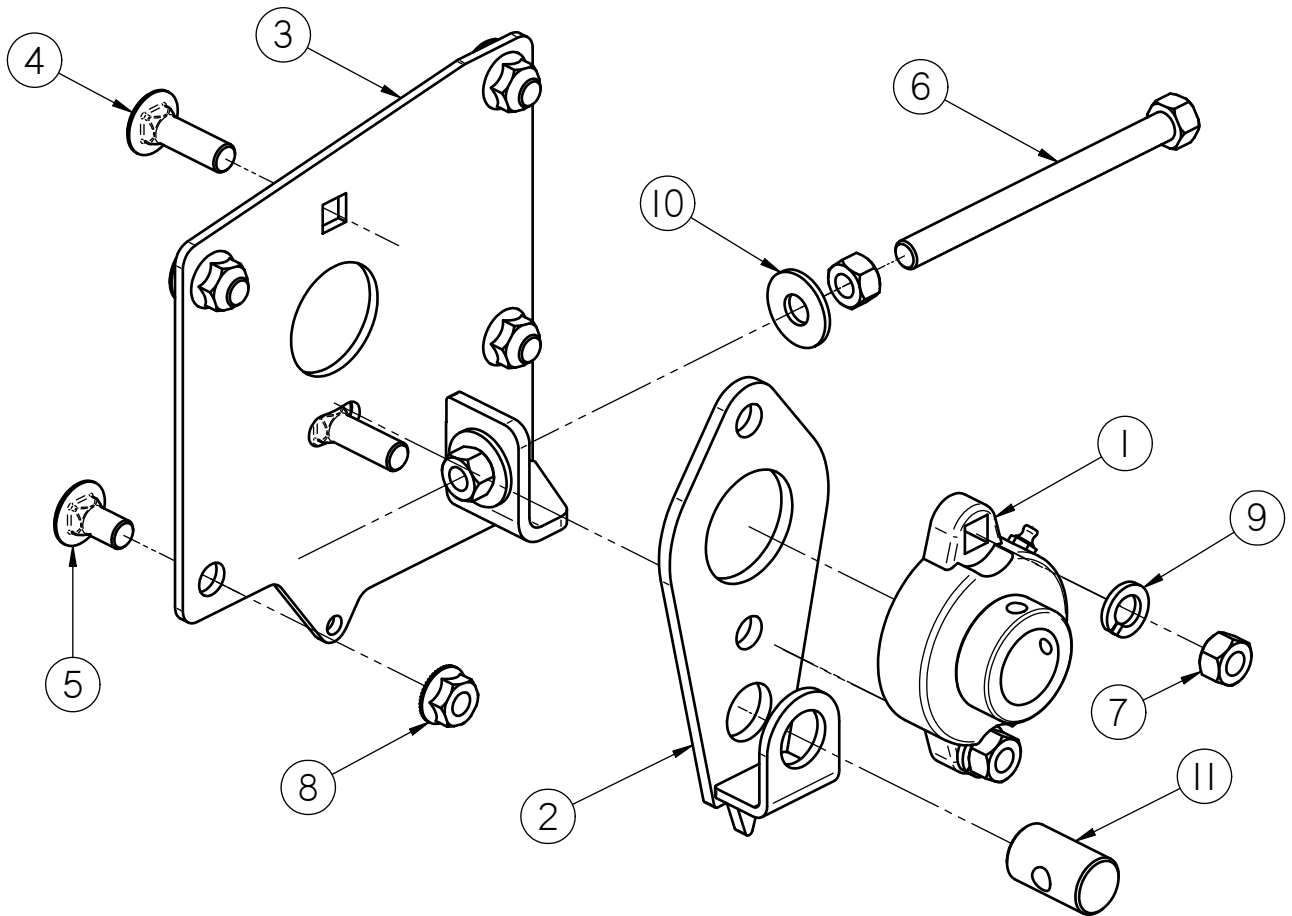

Item #	Part #	Description	Qty
1	01-03-0042	BRG FLG MNT 1.000ID 2BOLT ECNTRC	1
2	05-08-0484	WDMT TRACKING PIVOT	1
3	05-08-0494	WDMT TRACKING PLT HD	1
4	06-01-0127	BOLT CRG .375-16 X 1.25 ZP GR5	2
5	06-01-0153	BOLT CRG .375-16X.750 ZP SHORT NECK	4
6	06-01-0247	BOLT .375-16X4.5 HE G5 ZP FTH	1
7	06-02-0003	NUT FULL .375-16 ZP GR5	4
8	06-03-0014	NUT LOCK FLG .375-16 ZP GR5	4
9	06-04-0003	WSHR LOCK SPLT .375 ZP	2
10	06-05-0004	WSHR FLAT .375 ZP	2
11	104079	PIN TRACKING PIVOT	1

PORTABLE LPV TREATER

INLET CONVEYOR HEAD SECTION ASSEMBLY (13-08-0737)

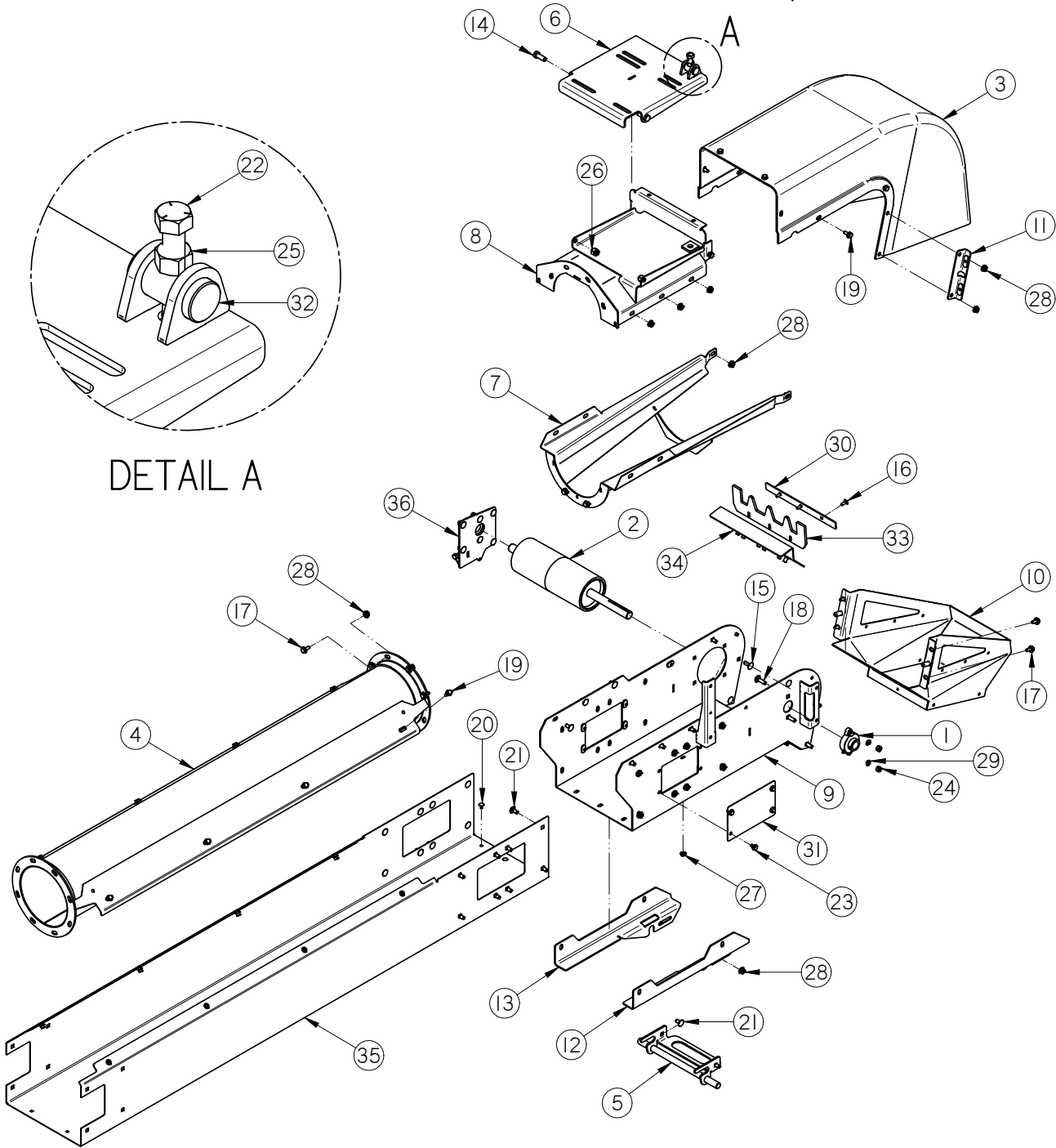

DETAIL A

PORTABLE LPV TREATER
INLET CONVEYOR HEAD SECTION ASSEMBLY (13-08-0737)

Item #	Part #	Description	Qty
1	01-03-0042	BRG FLG MNT 1.000ID 2BOLT ECNTRC	1
2	01-08-0109	PULLEY HEAD VULC TS2500	1
3	05-06-0131	COVER HD TS25 DD	1
4	05-08-0414	WDMT TUBE 8.00IN X 60IN	1
5	05-08-0529	WDMT LOCK PORT CNVR	1
6	05-08-0549	WDMT MTR MNT PLT LG	1
7	05-08-0564	WDMT HD TRANS TS25	1
8	05-08-0565	WDMT HD CVR TS25	1
9	05-08-0566	WDMT DSCHG HD TS25	1
10	05-08-0567	WDMT DSCHG HD SPOUT TS25	1
11	05-08-0568	WDMT DSCHG HD MNT PLT	2
12	05-10-4359	BRKT MNT PORT RH	1
13	05-10-4361	BRKT MNT PORT LH	1
14	06-01-0080	BOLT .500-13 X 1.25 ZP GR5	2
15	06-01-0115	BOLT CRG .375-16 X 1.00 ZP GR5	4
16	06-01-0122	BOLT, CARRIAGE, .250-20x.75 G5 ZP	3
17	06-01-0124	BOLT FLG .375-16 X .750 ZP GR5	10
18	06-01-0127	BOLT CRG .375-16 X 1.25 ZP GR5	2
19	06-01-0138	BOLT, FLG .3125-18 UNC ZP GRADE 5; 3/4" LG	16
20	06-01-0150	BOLT, CARRIAGE, .250-20x.50 G5 ZP	6
21	06-01-0153	BOLT CRG .375-16X.750 ZP SHORT NECK	32
22	06-01-0157	BOLT, .500-13 X 4" UNC ZP GRADE 5 fth	1
23	06-01-0261	BOLT FLG .3125-18 X .500 ZP GR5	8
24	06-02-0003	NUT FULL .375-16 ZP GR5	2
25	06-02-0004	NUT FULL .500-13 ZP GR5	1
26	06-03-0004	NUT NYL LOCK .500-13 ZP GR5	2
27	06-03-0013	NUT,LOCK, FLG .250-20 ZP SERRATED	9
28	06-03-0014	NUT LOCK FLG .375-16 ZP GR5	42
29	06-04-0003	WSHR LOCK SPLT .375 ZP	2
30	103B39	PLT SCRAPER HLDR 12IN CNVR	1
31	103B9A	PLT SPLICE COVER	2
32	10414A	PIN MTR PIVOT	1
33	104259	RBBR SCRAPER 12IN FILL	1
34	104C11	PLT BAFFLE MNT	1
35	13-05-0529	ASSY FRAME HD TS2532 W/RIVETNUTS	1
36	13-08-0564	ASSY TRACKING PLT HD	1

PORTABLE LPV TREATER

17 FT INLET CONVEYOR ASSEMBLY (17-13-0028)

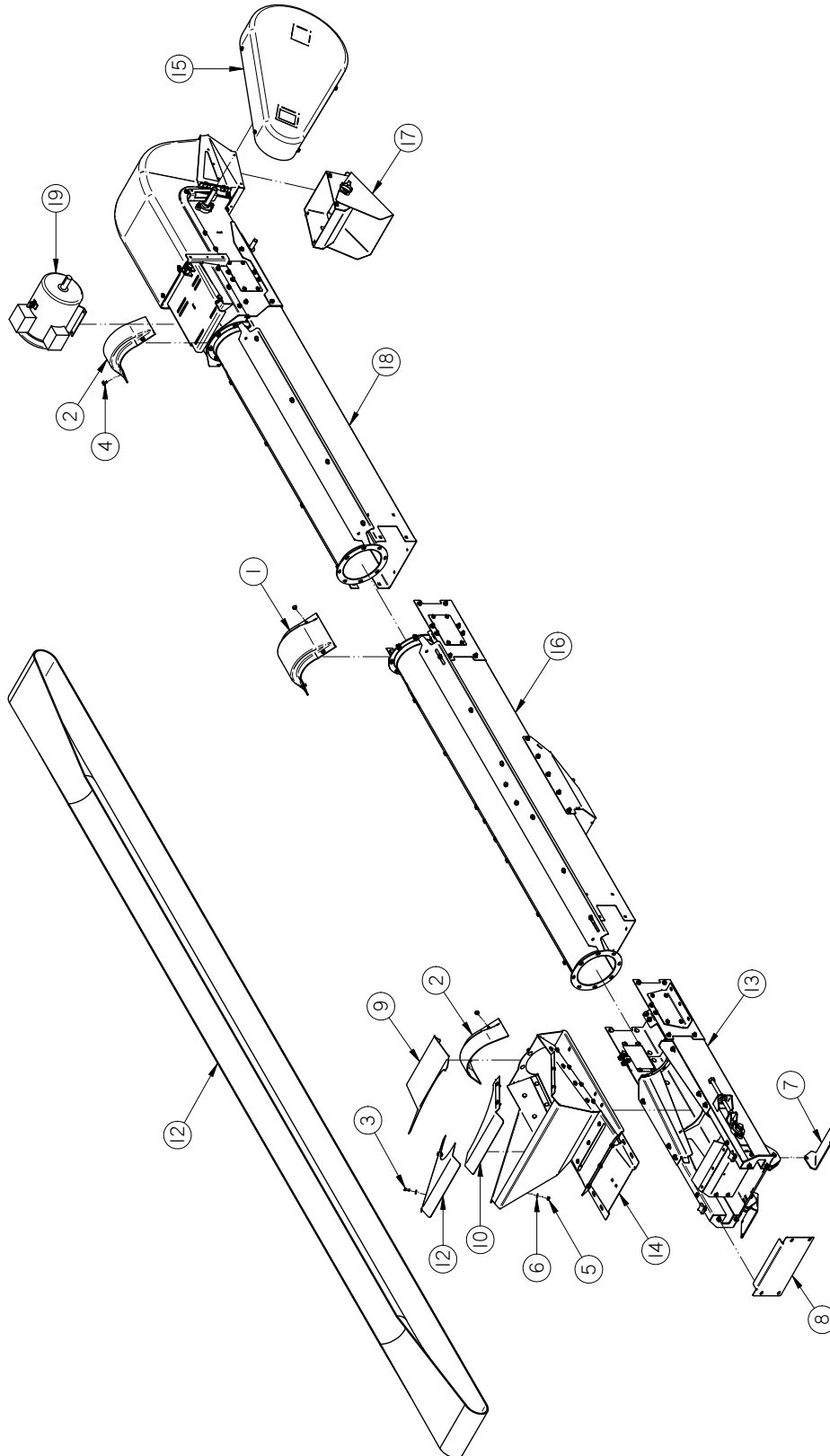

PORTABLE LPV TREATER

17 FT INLET CONVEYOR ASSEMBLY (17-13-0028)

Item #	Part #	Description	Qty
1	05-06-0111	CVR SPLICE RND CNVR 8IN	1
2	05-06-0112	CVR SPLICE INLET RND CNVR 8IN	2
3	06-01-0006	BOLT, .250-20 X .75 UNC ZP GRADE 5	4
4	06-01-0261	BOLT FLG .3125-18 X .500 ZP GR5	8
5	06-03-0001	NUT, LOCK, .250-20 ZP G5 NYLON INSERT	4
6	06-05-0001	WASHER, FLAT .250	8
7	102F37	FLR MNT CNVR BRKT	2
8	103B89	PLT REAR CVR	1
9	1053D5	PLT LG INLET DEFLECTOR	1
10	1058E0	PLT RH INLET CVR PORT	1
11	1058E1	PLT LH INLET CVR PORT	1
12	11-02-0136	BELT CNVR CLTS TS1217	1
13	13-08-0532	ASSY INLET SECT TS25	1
14	13-08-0540	ASSY LG INLET HOPPER TS25	1
15	13-08-0653	KIT DRIVE 5HP DD TS25	1
16	13-08-0668	ASSY INLET EXT CLEAN OUT	1
17	13-08-0705	ASSY ADJ SPOUT TS CNVRS	1
18	13-08-0737	ASSY HEAD SECT TS2517 LPV-PORT	1
19	SEE TABLE 1	CONVEYOR MOTOR	1

TABLE 1

Conveyor Part #	Motor Part #	Conveyor Description
17-13-0028	01-01-0107	INLET TREATER CONVEYOR 17FT 230V 1PH
17-13-0029	01-01-0151	INLET TREATER CONVEYOR 17FT 230V 3PH
17-13-0030	01-01-0209	INLET TREATER CONVEYOR 17FT 460V 3PH
17-13-0031	01-01-0143	INLET TREATER CONVEYOR 17FT 575V 3PH

PORTABLE LPV TREATER

OUTLET CONVEYOR INLET HOPPER ASSEMBLY (13-08-0736)

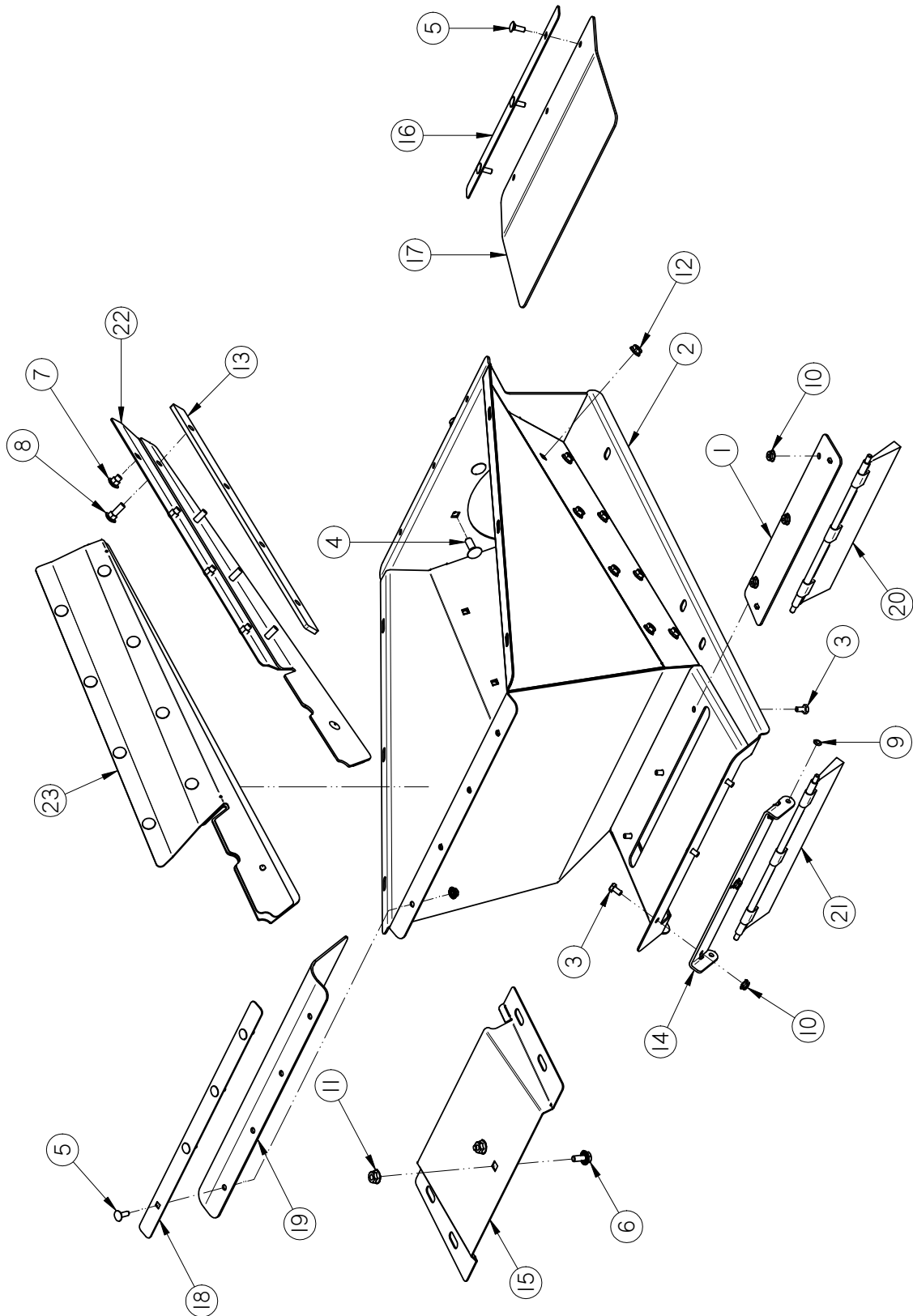

PORTABLE LPV TREATER

OUTLET CONVEYOR INLET HOPPER ASSEMBLY (13-08-0736)

Item #	Part #	Description	Qty
1	05-08-0536	WDMT PIVOT BRSH PLT TS25	1
2	05-08-0698	WDMT INLET HOP TS25 LPV PORT	1
3	06-01-0004	BOLT, .250-20 X .500 UNC ZP GRADE 5	6
4	06-01-0115	BOLT CRG .375-16 X 1.00 ZP GR5	2
5	06-01-0122	BOLT, CARRIAGE, .250-20x.75 G5 ZP	7
6	06-01-0124	BOLT FLG .375-16 X .750 ZP GR5	2
7	06-01-0129	BOLT CRG .313-18 X .50 ZP GR5	8
8	06-01-0223	BOLT CRG .313-18 X 1.00 ZP GR5	8
9	06-02-0100	PUSH NUT SS .250 UNTHREADED	2
10	06-03-0013	NUT,LOCK, FLG .250-20 ZP SERRATTED	13
11	06-03-0014	NUT LOCK FLG .375-16 ZP GR5	4
12	06-03-0019	NUT LOCK FLG .3125-18 ZP GR5	16
13	103D17	PLT SKIRT SPACER	2
14	10472A	EAR BRUSH MNT	1
15	105608	COVER CLN\OUT	1
16	105770	STRAP SEAL MNT	1
17	105771	INLET SEAL RBBR	1
18	105772	STRAP SEAL MNT	1
19	105773	INLET SEAL RBBR	1
20	13-05-0478	ASSY BRUSH W\CLIPS 11.25	1
21	13-05-0479	ASSY BRUSH W\CLIPS 11.88	1
22	13-05-0582	ASSY SKIRT RH TS25	1
23	13-05-0583	ASSY SKIRT RIGID TS25	1

PORTABLE LPV TREATER

OUTLET CONVEYOR INLET END ASSEMBLY (13-08-0710)

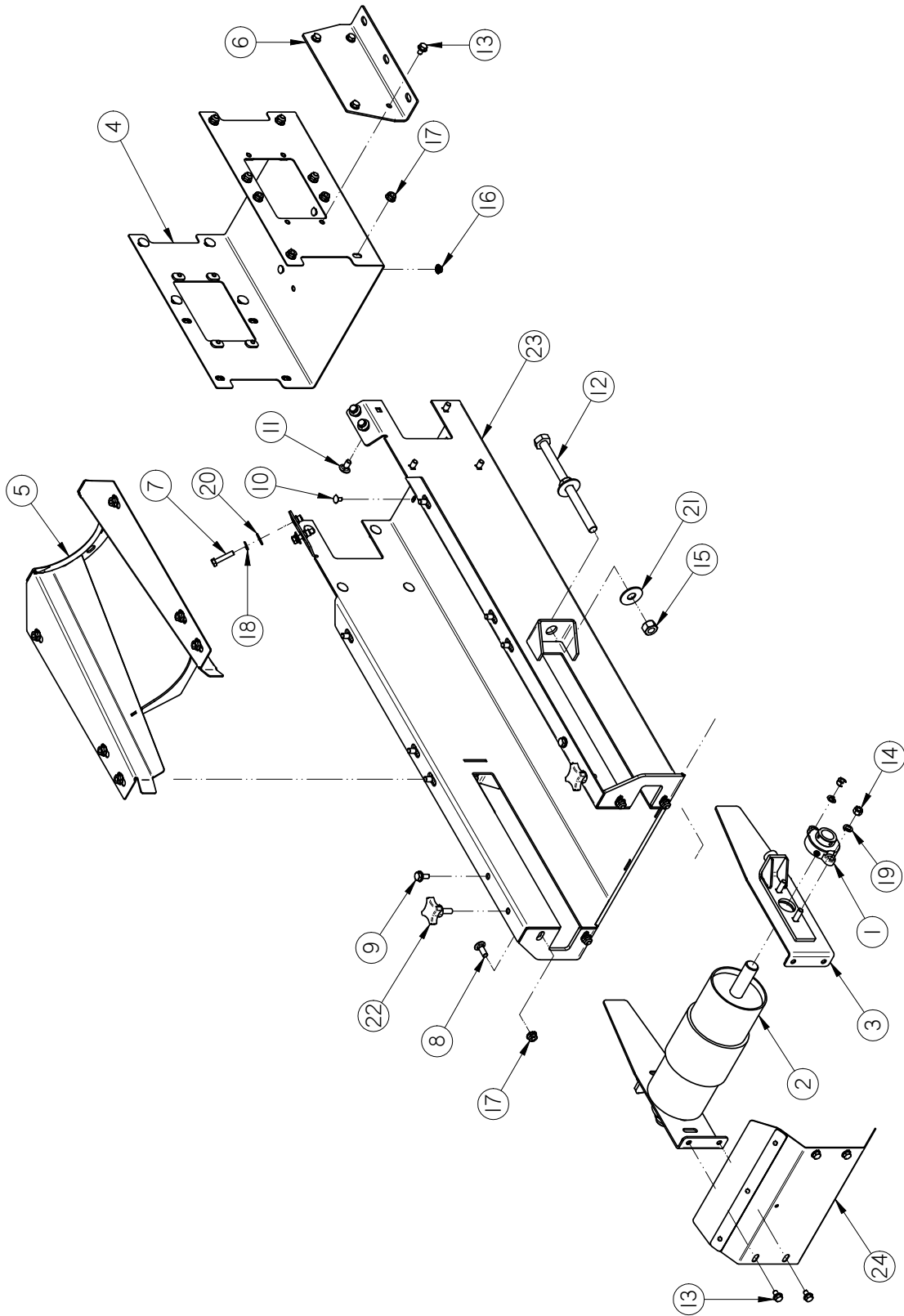

PORTABLE LPV TREATER

OUTLET CONVEYOR INLET END ASSEMBLY (13-08-0710)

Item #	Part #	Description	Qty
1	01-03-0042	BRG FLG MNT 1.000ID 2BOLT ECNTRC	2
2	01-08-0108	PULLEY TAIL W-LAGGING	1
3	05-08-0404	WDMT TAKE-UP PLT RND CNVR	2
4	05-08-0419	WDMT SPLICE 12IN	1
5	05-08-0569	WDMT TAIL TRANS TS25	1
6	05-10-4339	PLT STOP MOUNT	2
7	06-01-0013	BOLT, .312-18 UNC ZP GRADE 5; 1.50" LG	4
8	06-01-0115	BOLT CRG .375-16 X 1.00 ZP GR5	4
9	06-01-0124	BOLT FLG .375-16 X .750 ZP GR5	2
10	06-01-0150	BOLT, CARRIAGE, .250-20x.50 G5 ZP	4
11	06-01-0153	BOLT CRG .375-16X.750 ZP SHORT NECK	22
12	06-01-0249	BOLT .625-11 X 9.00 ZP GR5 FTH	2
13	06-01-0261	BOLT FLG .3125-18 X .500 ZP GR5	12
14	06-02-0003	NUT FULL .375-16 ZP GR5	4
15	06-02-0005	NUT, .625-11 UNC ZP GRADE 5	4
16	06-03-0013	NUT,LOCK, FLG .250-20 ZP SERRATED	4
17	06-03-0014	NUT LOCK FLG .375-16 ZP GR5	28
18	06-04-0002	WSHR LOCK SPLT .313 ZP	4
19	06-04-0003	WSHR LOCK SPLT .375 ZP	4
20	06-05-0003	WSHR FLAT .313 ZP	4
21	06-05-0006	WASHER, .625 FLAT ZP	4
22	06-09-0066	KNOB .375 -16 X 1. 4 LUG PLASTIC	2
23	13-05-0585	ASSY INLET W/RIVETNUTS TS25 PORT	1
24	13-08-0722	ASSY BAFFLE W/SEAL TS25	1

PORTABLE LPV TREATER

OUTLET CONVEYOR CLEAN OUT EXTENSION ASSEMBLY (13-08-0707)

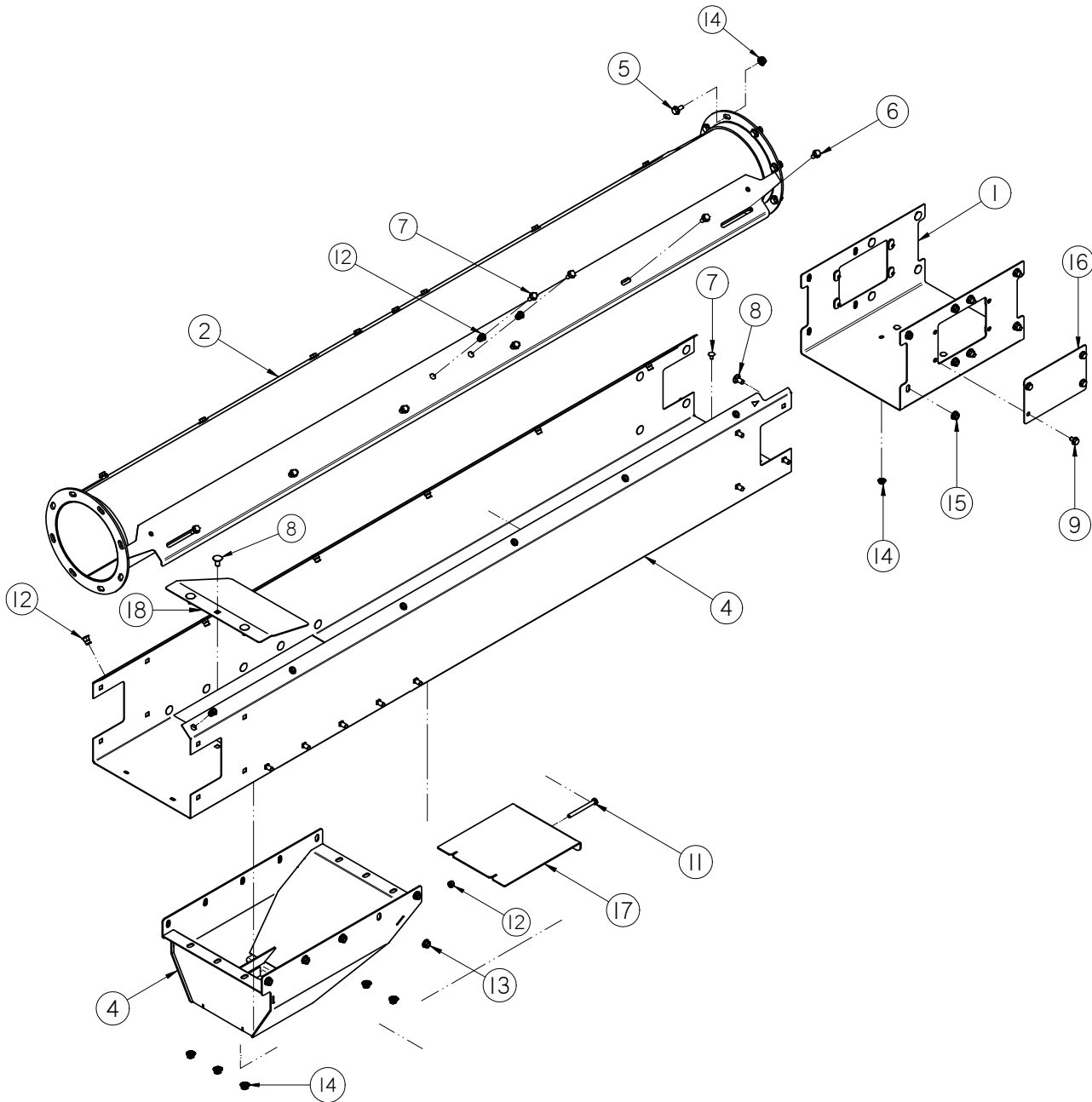

PORTABLE LPV TREATER

OULLET CONVEYOR CLEAN OUT EXTENSION ASSEMBLY (13-08-0707)

Item #	Part #	Description	Qty
1	05-08-0419	WDMT SPLICE 12IN	1
2	05-08-0461	WDMT TUBE 8.00IN X 84.86IN	1
3	05-08-0610	WDMT CLEAN OUT	1
4	05-10-4576	FRAME INLET SEC CLN/OUT TS25	1
5	06-01-0124	BOLT FLG .375-16 X .750 ZP GR5	8
6	06-01-0138	BOLT, FLG .3125-18 UNC ZP GRADE 5; 3/4" LG	16
7	06-01-0150	BOLT, CARRIAGE, .250-20x.50 G5 ZP	4
8	06-01-0153	BOLT CRG .375-16X.750 ZP SHORT NECK	32
9	06-01-0261	BOLT FLG .3125-18 X .500 ZP GR5	8
10	06-01-0311	BOLT .313-18 X 3.25 ZP GR5	1
11	06-02-0092	RIVETNUT .312-18 ZP	16
12	06-03-0002	NUT NYL LOCK .313-18 ZP GR5	1
13	06-03-0013	NUT,LOCK, FLG .250-20 ZP SERRATED	4
14	06-03-0014	NUT LOCK FLG .375-16 ZP GR5	40
15	103B9A	PLT SPLICE COVER	2
16	1050CF	PLT DOOR CLEAN OUT	1
17	1050E8	PLT BELT GUIDE	1

PORTABLE LPV TREATER

OUTLET CONVEYOR HEAD SECTION ASSEMBLY (13-08-0652)

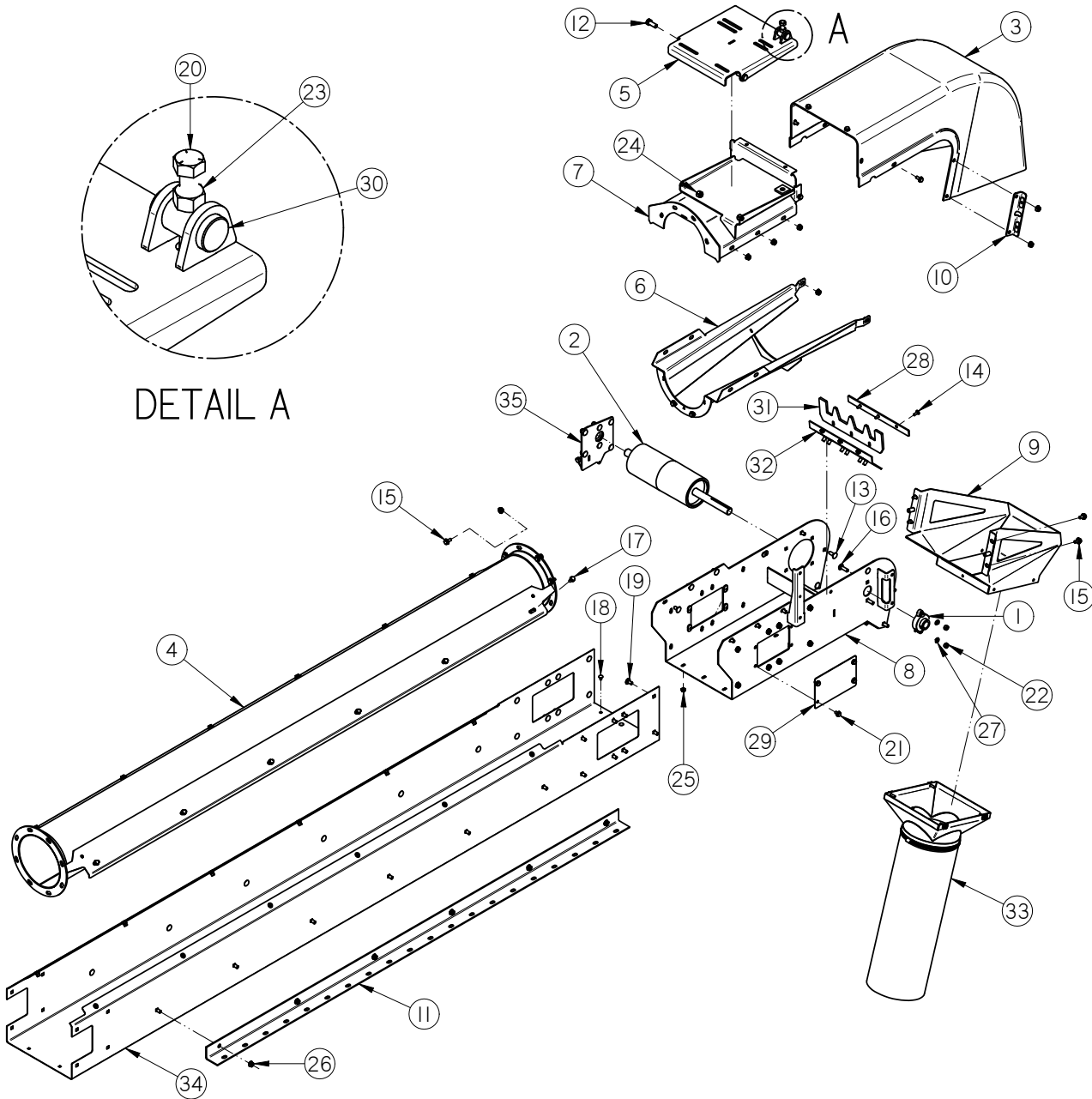

PORTABLE LPV TREATER

OUTLET CONVEYOR HEAD SECTION ASSEMBLY (13-08-0652)

Item #	Part #	Description	Qty
1	01-03-0042	BRG FLG MNT 1.000ID 2BOLT ECNTRC	1
2	01-08-0109	PULLEY HEAD VULC TS2500	1
3	05-06-0131	COVER HD TS25 DD	1
4	05-08-0416	WDMT TUBE 8.00IN X 95.14IN	1
5	05-08-0549	WDMT MTR MNT PLT LG	1
6	05-08-0564	WDMT HD TRANS TS25	1
7	05-08-0565	WDMT HD CVR TS25	1
8	05-08-0566	WDMT DSCHG HD TS25	1
9	05-08-0567	WDMT DSCHG HD SPOUT TS25	1
10	05-08-0568	WDMT DSCHG HD MNT PLT	2
11	05-10-4028	TRANSPORT STOP PLT EXT MNT	2
12	06-01-0080	BOLT .500-13 X 1.25 ZP GR5	2
13	06-01-0115	BOLT CRG .375-16 X 1.00 ZP GR5	4
14	06-01-0122	BOLT, CARRIAGE, .250-20x.75 G5 ZP	3
15	06-01-0124	BOLT FLG .375-16 X .750 ZP GR5	10
16	06-01-0127	BOLT CRG .375-16 X 1.25 ZP GR5	2
17	06-01-0138	BOLT, FLG .3125-18 UNC ZP GRADE 5; 3/4" LG	18
18	06-01-0150	BOLT, CARRIAGE, .250-20x.50 G5 ZP	6
19	06-01-0153	BOLT CRG .375-16X.750 ZP SHORT NECK	42
20	06-01-0157	BOLT, .500-13 X 4" UNC ZP GRADE 5 fth	1
21	06-01-0261	BOLT FLG .3125-18 X .500 ZP GR5	8
22	06-02-0003	NUT FULL .375-16 ZP GR5	2
23	06-02-0004	NUT FULL .500-13 ZP GR5	1
24	06-03-0004	NUT NYL LOCK .500-13 ZP GR5	2
25	06-03-0013	NUT,LOCK, FLG .250-20 ZP SERRATTED	9
26	06-03-0014	NUT LOCK FLG .375-16 ZP GR5	52
27	06-04-0003	WSHR LOCK SPLT .375 ZP	2
28	103B39	PLT SCRAPER HLDR 12IN CNVR	1
29	103B9A	PLT SPLICE COVER	2
30	10414A	PIN MTR PIVOT	1
31	104259	RBBR SCRAPER 12IN FILL	1
32	104C11	PLT BAFFLE MNT	1
33	13-05-0227	ASSY 8ID FLEX SPOUT S2000	1
34	13-05-0508	ASSY FRAME HD TS25 DD W/RIVETNUTS	1
35	13-08-0564	ASSY TRACKING PLT HD	1

PORTABLE LPV TREATER

20 FT OUTLET CONVEYOR BASE ASSEMBLY (13-08-0706)

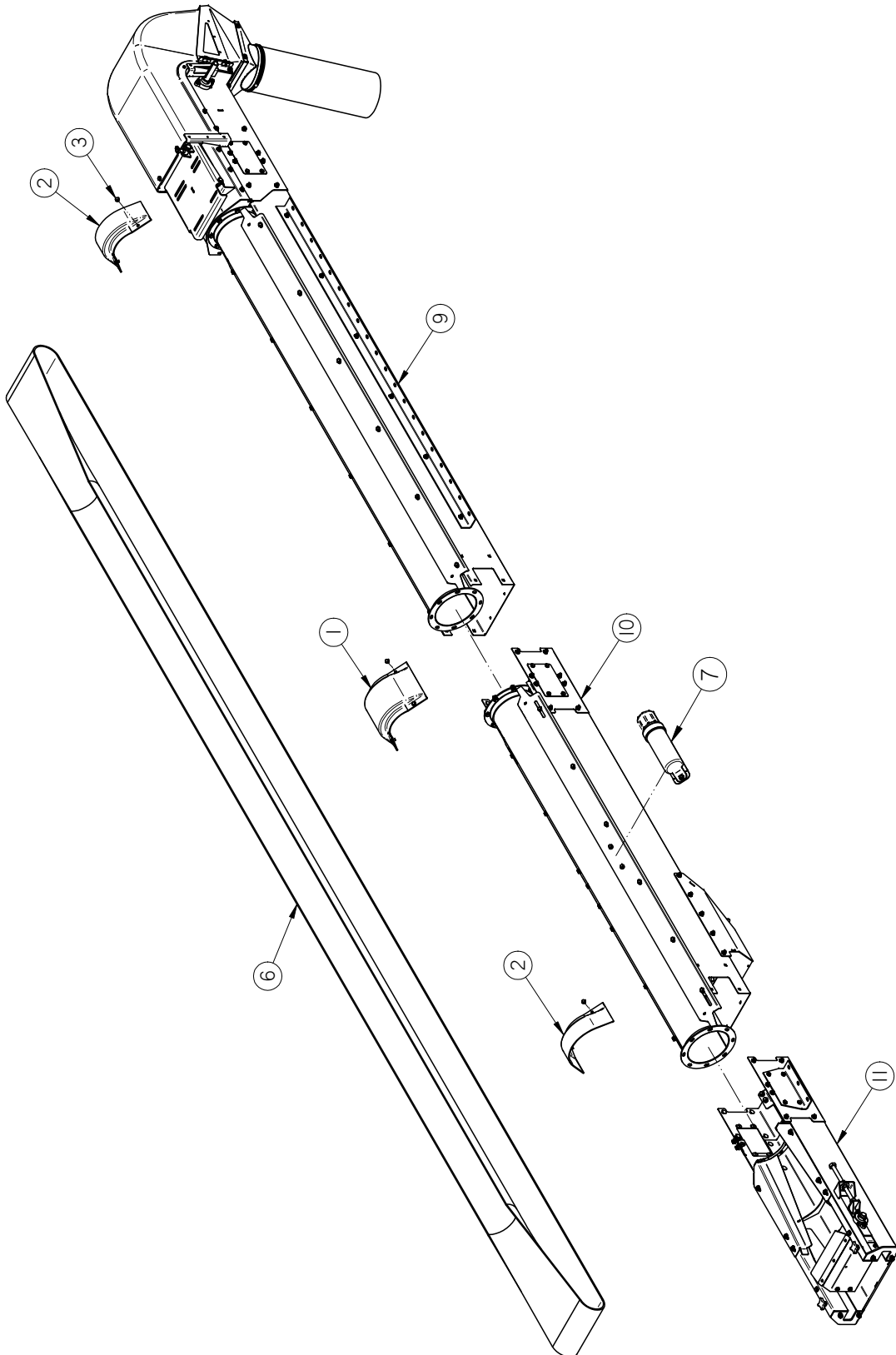

PORTABLE LPV TREATER

20 FT OUTLET CONVEYOR BASE ASSEMBLY (13-08-0706)

Item #	Part #	Description	Qty
1	05-06-0111	CVR SPLICE RND CNVR 8IN	1
2	05-06-0112	CVR SPLICE INLET RND CNVR 8IN	2
3	06-01-0261	BOLT FLG .3125-18 X .500 ZP GR5	8
4	09-01-0178	LBL ATWK TS2520	2
5	09-02-0016	LBL ATWRK ATT BELT ALIGN	1
6	11-02-0139	BELT CNVR CLTS TS3520	1
7	13-05-0332	ASSY MANUAL TUBE MT	1
8	13-05-0353	DECAL PKG TS CNVRS	1
9	13-08-0652	ASSY HEAD SECT TS25 DD	1
10	13-08-0707	ASSY INLET CLN/OUT TS25 PORT	1
11	13-08-0710	ASSY INLET SECT TS25 PORT	1

NOTE: Items 4,5 and 8 not shown on drawing.

PORTABLE LPV TREATER

20 FT OUTLET CONVEYOR TOP ASSEMBLY

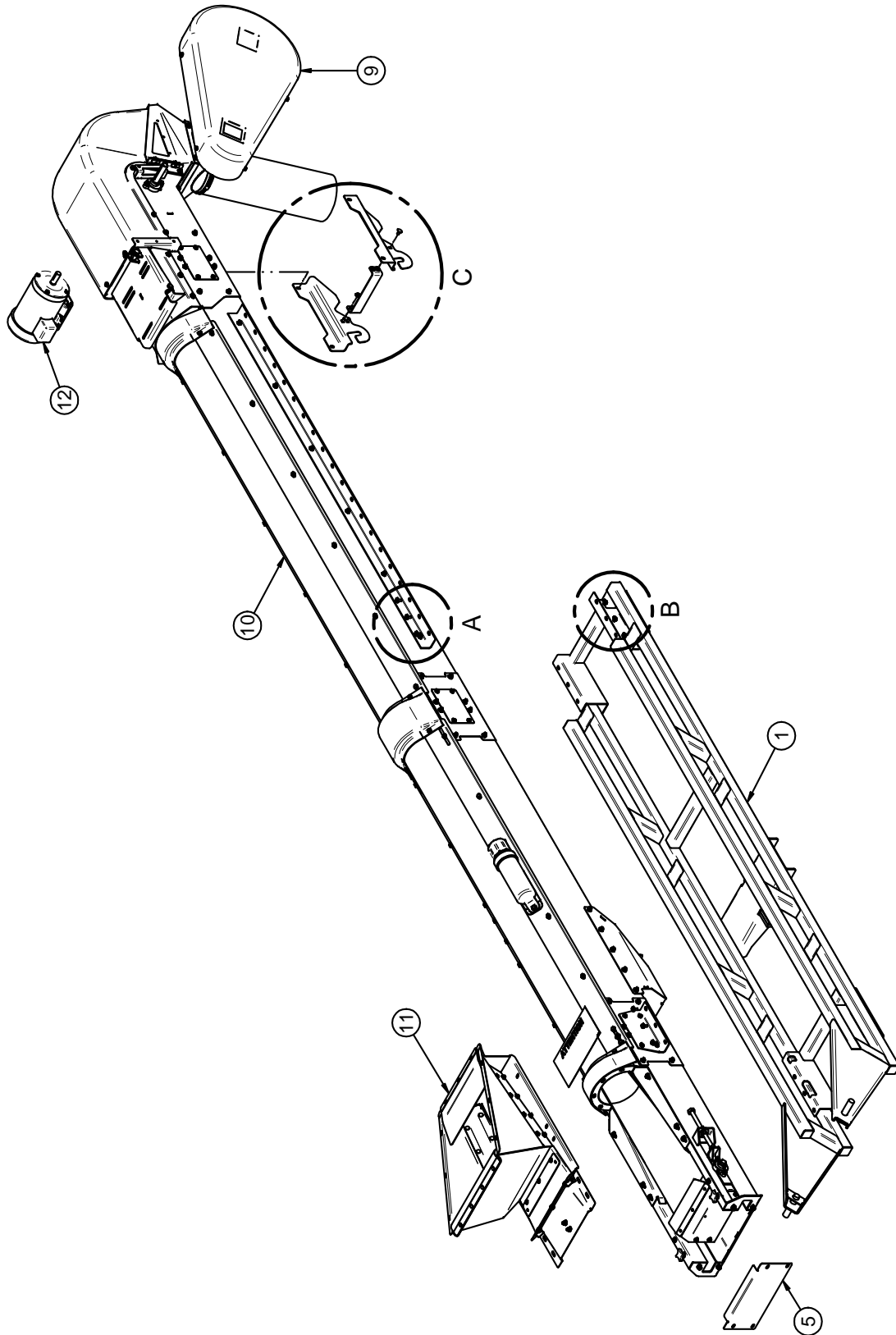

PORTABLE LPV TREATER

20 FT OUTLET CONVEYOR TOP ASSEMBLY

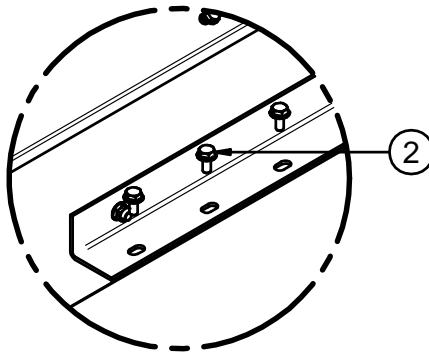

DETAIL A

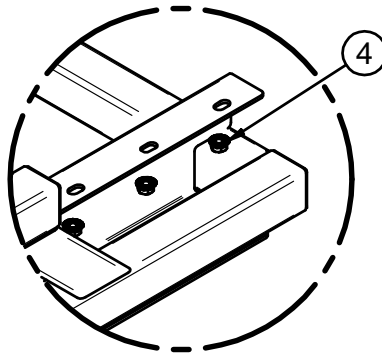

DETAIL B

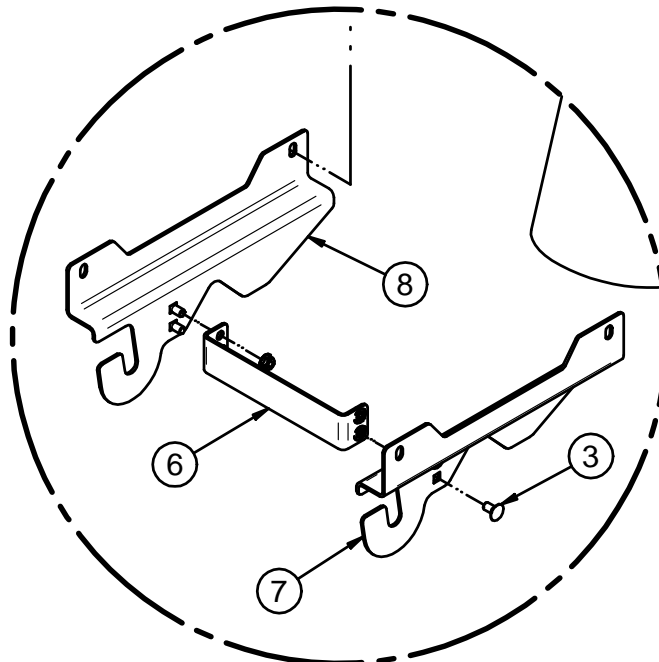

DETAIL C

PORTABLE LPV TREATER

20 FT OUTLET CONVEYOR TOP ASSEMBLY

Item #	Part #	Description	Qty
1	05-03-1689	WDMT PORT OUTLET CNVR SUPP FRM	1
2	06-01-0124	BOLT FLG .375-16 X .750 ZP GR5	12
3	06-01-0153	BOLT CRG .375-16X.750 ZP SHORT NECK	4
4	06-03-0014	NUT LOCK FLG .375-16 ZP GR5	16
5	103B89	PLT REAR CVR	1
6	1058EF	STRAP TIE	1
7	1058FE	PLT CNVR LOCK RH	1
8	1058FF	PLT CNVR LOCK LH	1
9	13-08-0653	KIT DRIVE 5HP DD TS25	1
10	13-08-0706	ASSY TS25 20FT BASE PORT	1
11	13-08-0736	ASSY INLET HOP TS25 LPV PORT	1
12	SEE TABLE 1	CONVEYOR DRIVE MOTOR	1

TABLE 1

Conveyor Part #	Motor Part #	Conveyor Description
17-13-0024	01-01-0107	OUTLET TREATER CONVEYOR 20FT 230V 1PH
17-13-0025	01-01-0151	OUTLET TREATER CONVEYOR 20FT 230V 3PH
17-13-0026	01-01-0209	OUTLET TREATER CONVEYOR 20FT 460V 3PH
17-13-0027	01-01-0143	OUTLET TREATER CONVEYOR 20FT 575V 3PH

PORTABLE LPV TREATER
FILL HOPPER ASSEMBLY (13-04-0127)

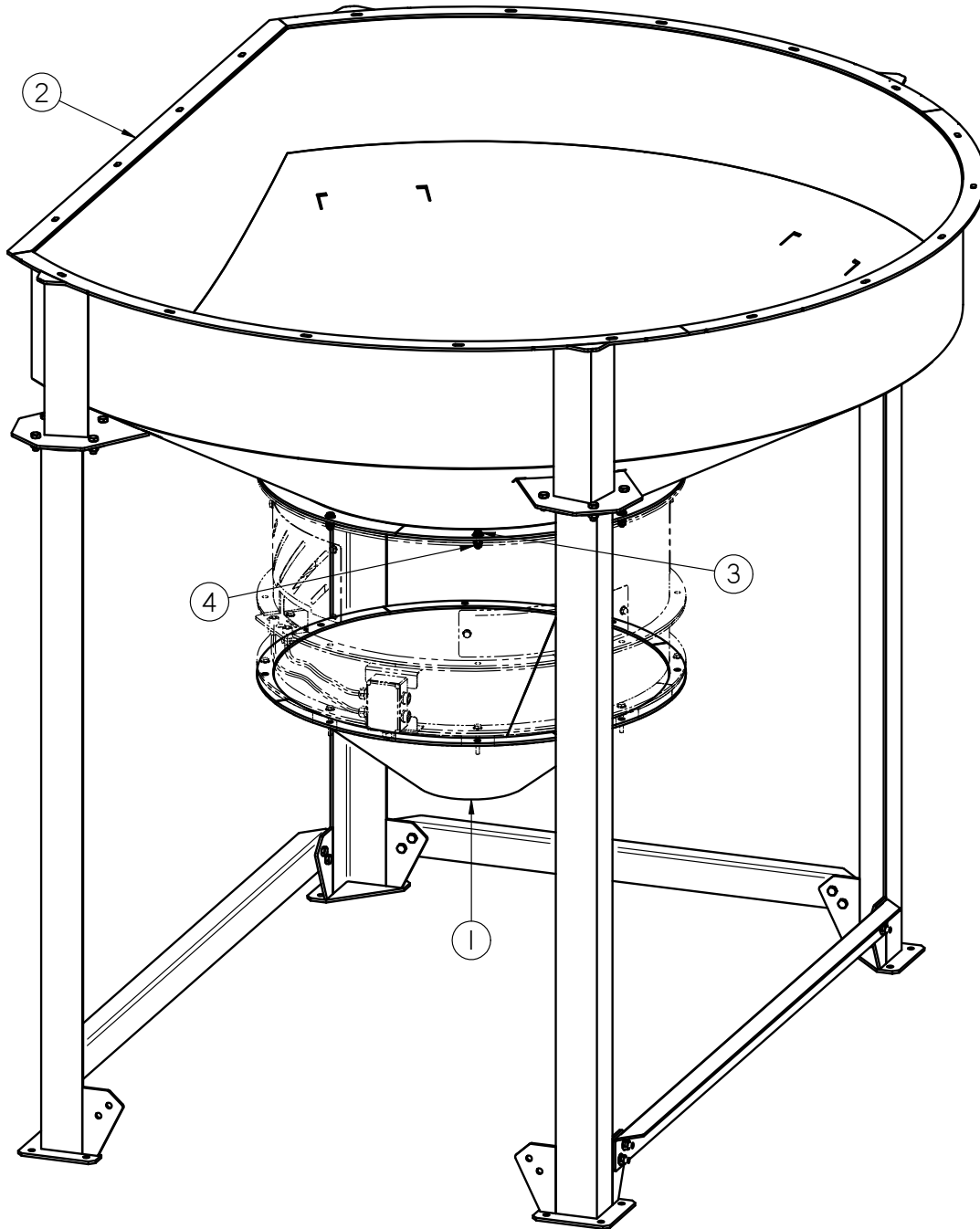

Item #	Part #	Description	Qty
1	05-03-0282	WDMT HOPP SMW DSCHG	1
2	05-07-0080	HOPP S2000 PORT FOR SMW	1
3	06-01-0189	BOLT FLG .375-16 X 1.250 ZP GR5	8
4	06-03-0014	NUT LOCK FLG .375-16 ZP GR5	8

PORTABLE LPV TREATER

LPV PORTABLE HARDWARE KIT (13-10-0055)

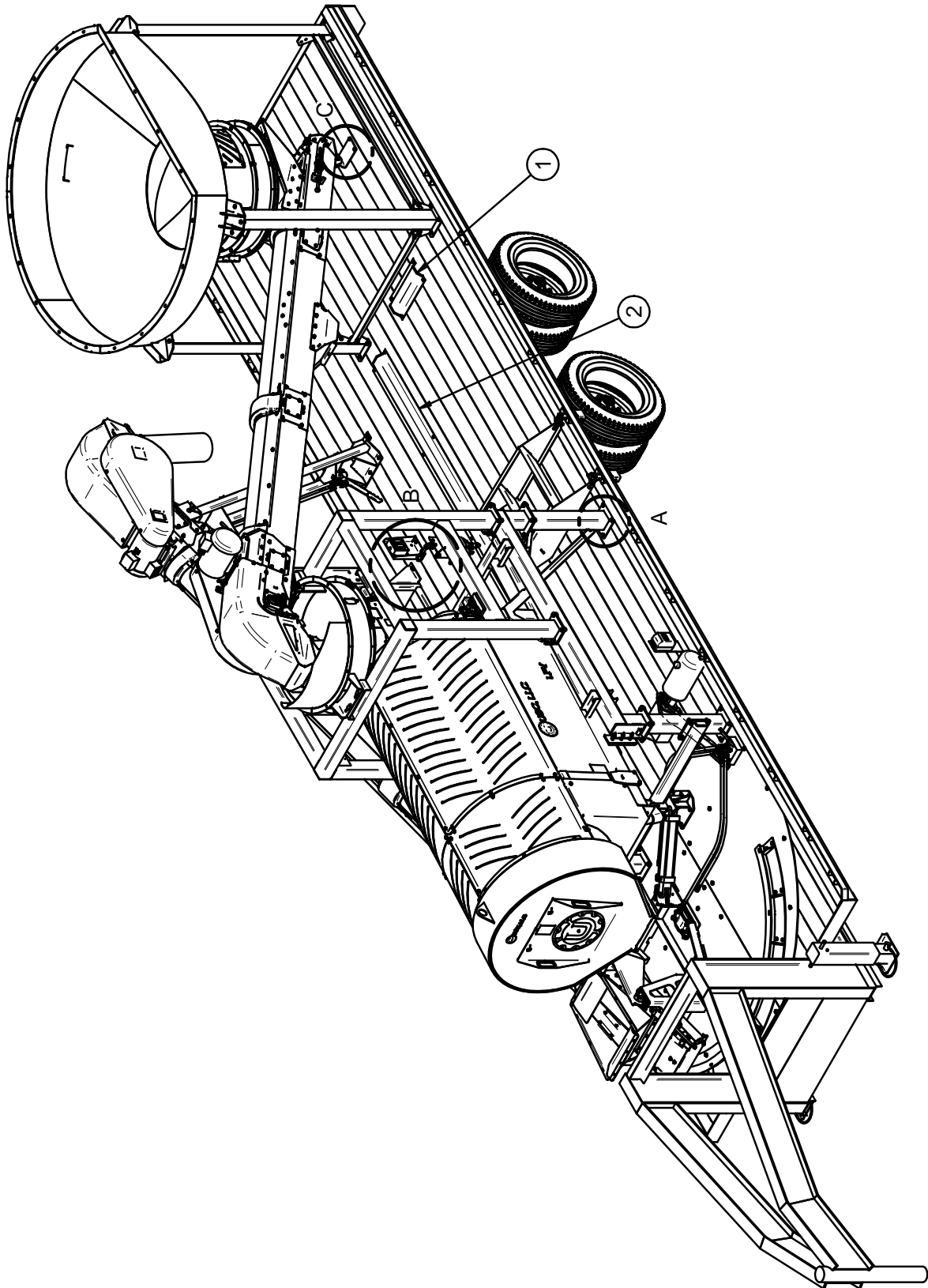

PORTABLE LPV TREATER

LPV PORTABLE HARDWARE KIT (13-10-0055)

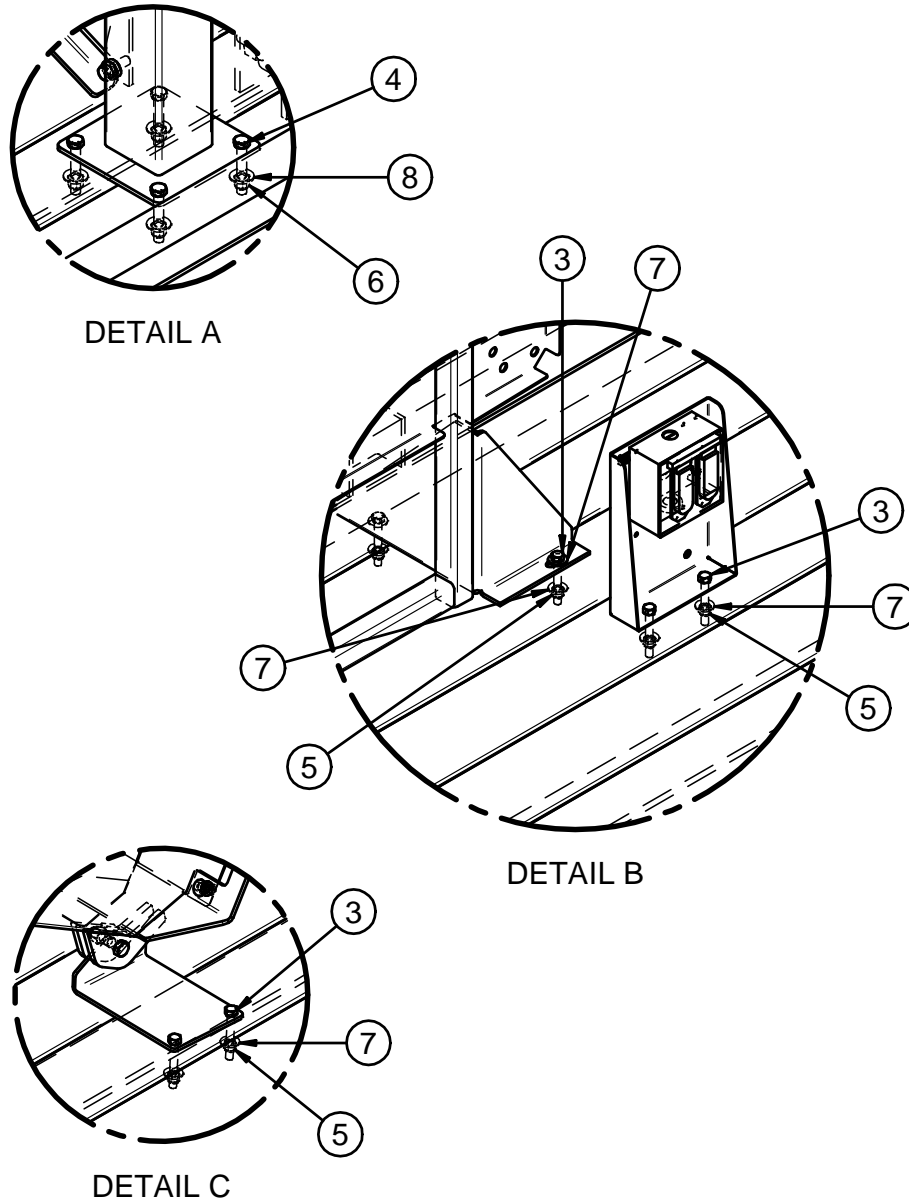

Item #	Part #	Description	Qty
1	05-06-0109	ASSY CVR WIRE/HOSE GRD	1
2	05-06-0110	ASSY CVR WIRE/HOSE GRD	1
3	06-01-0116	BOLT .375-16 X 2.75 ZP GR5	14
4	06-01-0252	BOLT .500-13 X 3.00 ZP GR5	28
5	06-03-0003	NUT NYL LOCK .375-16 ZP GR5	14
6	06-03-0004	NUT NYL LOCK .500-13 ZP GR5	28
7	06-05-0004	WSHR FLAT .375 ZP	22
8	06-05-0005	WSHR FLAT .500 ZP	28

PORTABLE LPV TREATER

DRY ADDITIVE FEEDER FLAT MOUNTING ASSEMBLY (05-07-0933)

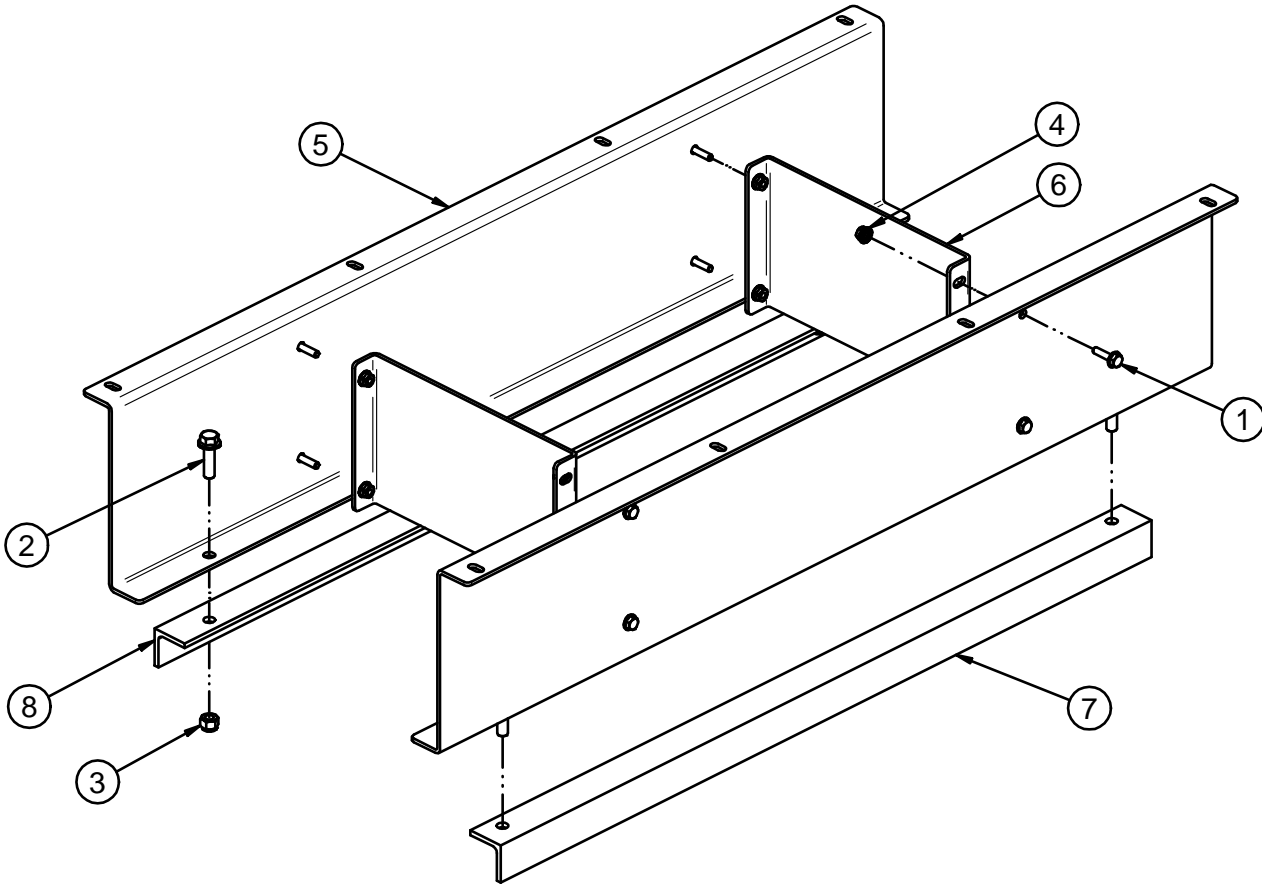

Item #	Part #	Description	Qty
1	06-01-0189	BOLT FLG .375-16 X 1.250 ZP GR5	8
2	06-01-0271	BOLT FLG .500-13 X 1.750 ZP	4
3	06-03-0004	NUT NYL LOCK .500-13 ZP GR5	4
4	06-03-0014	NUT LOCK FLG .375-16 ZP GR5	8
5	10570A	DAF MNT BRKT PORT	2
6	10570B	DAF MNT BRKT PORT	2
7	10611E	ANGL CLAMP SHORT	1
8	106120	ANGLE CLAMP LONG	1

PORTABLE LPV TREATER

DRY ADDITIVE FEEDER ANGLE MOUNTING ASSEMBLY (05-07-1007)

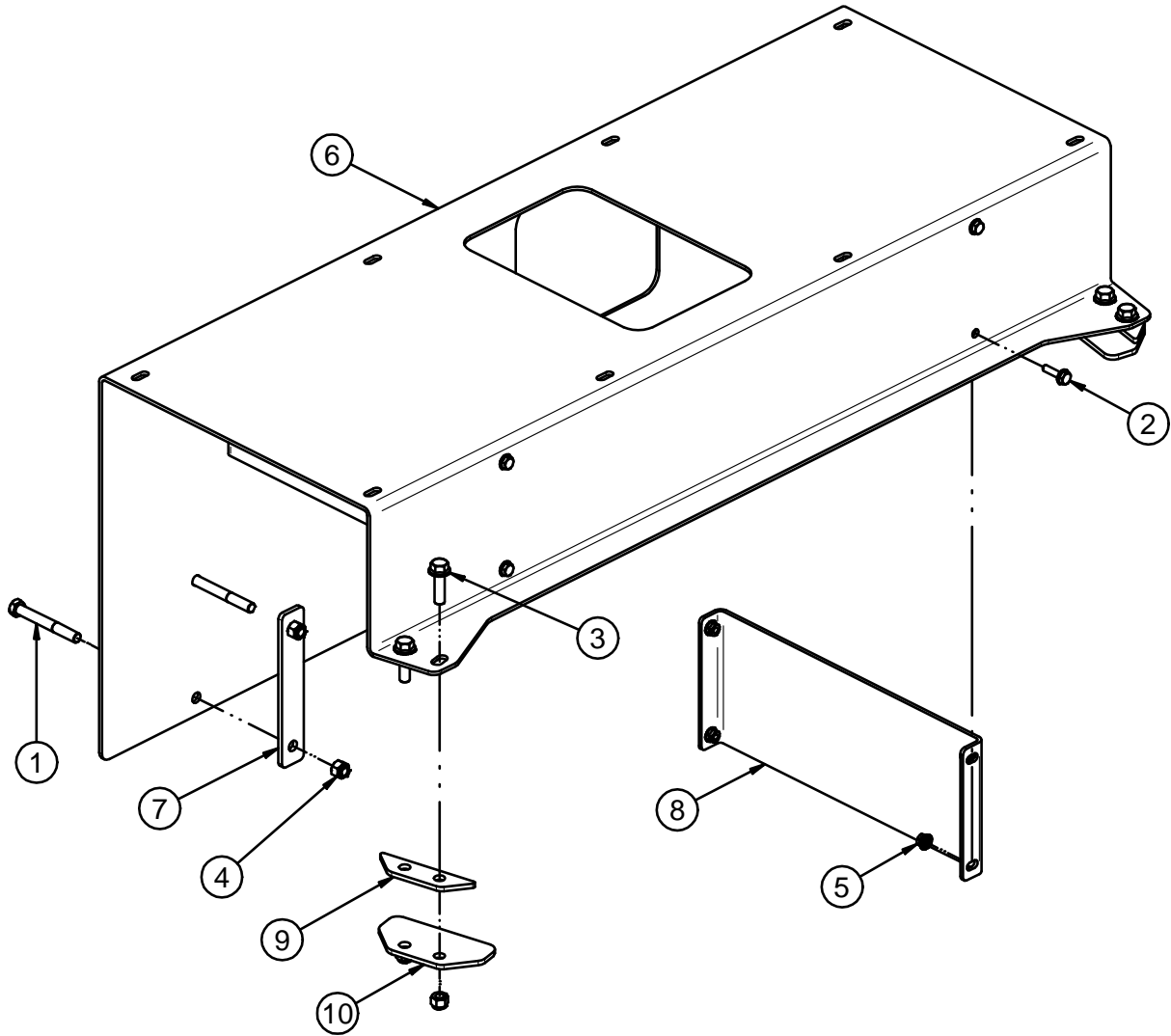

Item #	Part #	Description	Qty
1	06-01-0030	BOLT, .500-13 X 4" UNC ZP GRADE 5	6
2	06-01-0189	BOLT FLG .375-16 X 1.250 ZP GR5	8
3	06-01-0271	BOLT FLG .500-13 X 1.750 ZP	4
4	06-03-0004	NUT NYL LOCK .500-13 ZP GR5	10
5	06-03-0014	NUT LOCK FLG .375-16 ZP GR5	8
6	106256	PLT DAF MNT PORT	1
7	106259	PLT MNT CLMP	3
8	10625A	DAF MNT BRKT PORT	2
9	10625D	PLT CLMP SPACER	2
10	10625E	PLT CLAMP	2

PORTABLE LPV TREATER
DRY ADDITIVE FEEDER ASSEMBLY

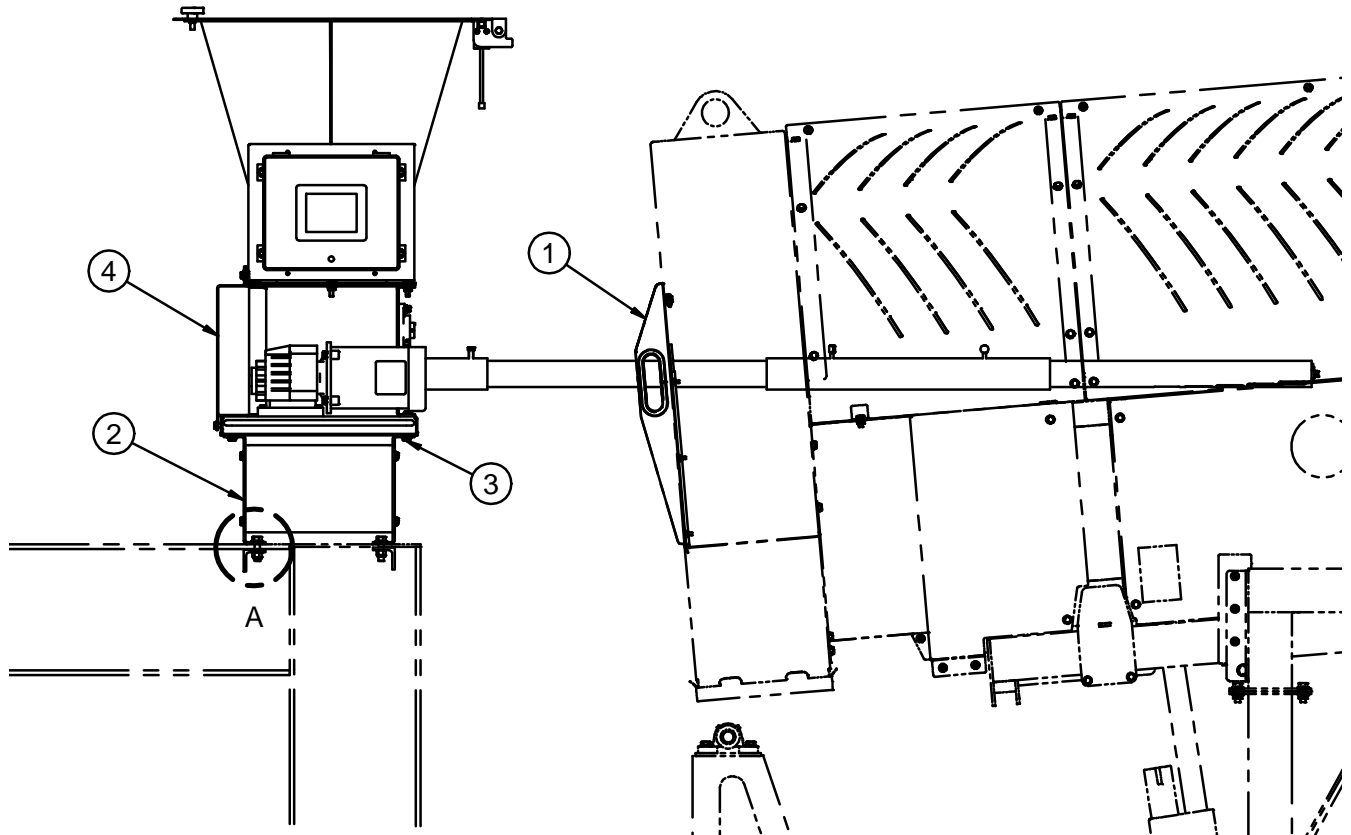

DETAIL A

Item #	Part #	Description	Qty
1	05-07-0924	ASSY END CHUTE DOOR DAF GALV	1
2	05-07-0933	ASSY DAF MNT GOOSENECK	1
3	06-01-0124	BOLT FLG .375-16 X .750 ZP GR5	4
4	13-05-0373	DAF 2046 CS 84IN REMV TUBE	1

USC LIMITED WARRANTY**SECTION
J**

USC, LLC, (Manufacturer) warrants its seed treating equipment as follows:

1. **Limited Warranty:** Manufacturer warrants that the Products sold hereunder will be free from defects in material and workmanship for a period of 18 months from date of shipment. If the Products do not conform to this Limited Warranty during the warranty period, Buyer shall notify Manufacturer in writing of the claimed defects and demonstrate to Manufacturer satisfaction that said defects are covered by this Limited Warranty. If the defects are properly reported to Manufacturer within the warranty period, and the defects are of such type and nature as to be covered by this warranty, Manufacturer shall, at its expense, furnish replacement Products or, at Manufacturer's option, replacement parts for the defective products. Shipping and installation of the replacement Products or replacement parts shall be at the Buyer's expense.
2. **Other Limits:** THE FOREGOING IS IN LIEU OF ALL OTHER WARRANTIES, EXPRESSED OR IMPLIED, INCLUDING BUT NOT LIMITED TO THE IMPLIED WARRANTIES OF MERCHANTABILITY AND FITNESS FOR A PARTICULAR PURPOSE. Manufacturer does not warrant against damages or defects arising from improper installation (where installation is by persons other than Manufacturer), against defects in products or components not manufactured by Manufacturer, or against damages resulting from such non-Manufacturer made products or components. Manufacturer passes on to the Buyer the warranty it received (if any) from the maker of such non-Manufacturer made products or components. This warranty also does not apply to Products upon which repairs and / or modifications have been effected or attempted by persons other than pursuant to written authorization by Manufacturer. This includes any welding on equipment which could damage electrical components. Manufacturer does not warrant against casualties or damages resulting from misuse and / or abuse of Products, improper storage or handling, acts of nature, effects of weather, including effects of weather due to outside storage, accidents, or damages incurred during transportation by common carrier.
3. **Exclusive Obligation:** THIS WARRANTY IS EXCLUSIVE. The sole and exclusive obligation of Manufacturer shall be to repair or replace the defective Products in the manner and for the period provided above. Manufacturer shall not have any other obligation with respect to the Products or any part thereof, whether based on contract, tort, strict liability or otherwise. Under no circumstances, whether based on this Limited Warranty or otherwise, shall Manufacturer be liable for lost profits, lost revenue, lost sales (whether direct or indirect damages), incidental, special, punitive, indirect or consequential damages.
4. **Other Statements:** Manufacturer's employees or representatives' oral or other written statements do not constitute warranties, shall not be relied upon by Buyer, and are not a part of the contract for sale or this limited warranty.
5. **Return Policy:** Approval is required prior to returning goods to Manufacturer. A restocking fee will apply.
6. **Entire Obligation:** This Limited Warranty states the entire obligation of Manufacturer with respect to the Products. If any part of this Limited Warranty is determined to be void or illegal, the remainder shall remain in full force and effect.

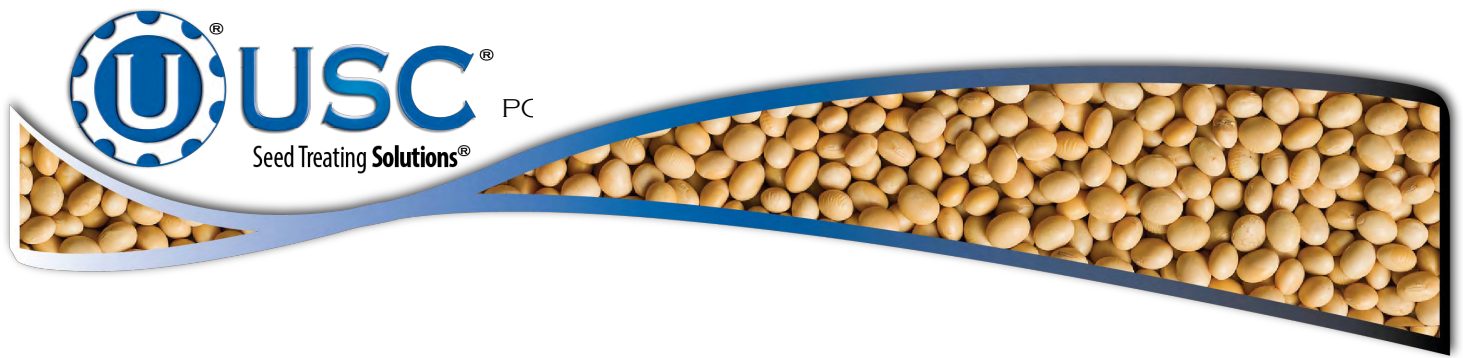

USC, LLC

2320 124th road

Sabetha, KS 66534

PHONE: (785) 431-7900

FAX: (785) 431-7950

EMAIL: sales-team@uscllc.com

WEB: www.uscllc.com

