

SEED SERIES 16 CONVEYORS



Operators Manual

Document: TD-09-06-1047

Revision: B



INTRODUCTION

Thank you for choosing USC, LLC for your equipment needs. We appreciate your business and will work diligently to ensure that you are satisfied with your choice.

OVERVIEW

The purpose of this manual is to provide you with the basic information needed to operate and maintain the “S” Series Conveyor. It does not hold USC, LLC liable for any accidents or injuries that may occur.

OPERATOR RESPONSIBILITIES

As the purchaser/owner/operator of this equipment and control system, you have an obligation to install, operate, and maintain the equipment in a manner that minimizes the exposure of people in your care to any potential hazards inherent in using this equipment. It is critical that the owner of this equipment:

- Has a clear and documented understanding of the process this machine is being used in and of any resulting hazards or special requirements arising from this specific application.
- Allow only properly trained and instructed personnel to install, operate, or service this equipment.
- Maintain a comprehensive safety program involving all who work with this machine and other associated process equipment.
- Establish clear areas of staff responsibility (e.g. operation, setup, sanitation, maintenance, and repairs).
- Provide all personnel with necessary safety equipment.
- Periodically inspect the equipment to insure that the doors, covers, guards, and safety devices are in place and functioning, that all safety instructions and warning labels are intact and legible, and that the equipment is in good working order.
- In addition to the operating instructions, observe and enforce the applicable legal and other binding regulations, national and local codes.

As the person with the most to gain or lose from working safely, it is important that you work responsibly and stay alert. By following a few simple rules, you can prevent an accident that could injure or kill you or a co-worker.

- Disconnect, lockout, and tagout electrical and all other energy sources before inspecting, cleaning, servicing, repairing, or any other activity that would expose you to the hazards of electrical shock.

SEED SERIES 16 CONVEYOR

- Do not operate, clean, or service this equipment until you have read and understood the contents of this manual. If you do not understand the information in this manual, bring it to the attention of your supervisor, or call your local USC dealer for assistance.
- Any operator who is known or suspected to be under the influence of alcohol or drugs should not be allowed to operate the equipment.
- Understand and follow the safety practices required by your employer and this manual.
- **PAY ATTENTION** to what you and other personnel are doing and how these activities may affect your safety.
- **Failure to follow these instructions may result in serious personal injury or death.**

RECEIVING YOUR EQUIPMENT

As soon as the equipment is received, it should be carefully inspected to make certain that it has sustained no damage during shipment and that all items listed on the packing list are accounted for. If there is any damage or shortages, the purchaser must immediately notify your USC dealer. Ownership passes to purchaser when the unit leaves the USC, LLC premises. The purchaser is responsible for unloading and mounting all components of the equipment.

Document the serial number of the machine for future reference. The serial number is located on the side of the conveyor near the hitch.

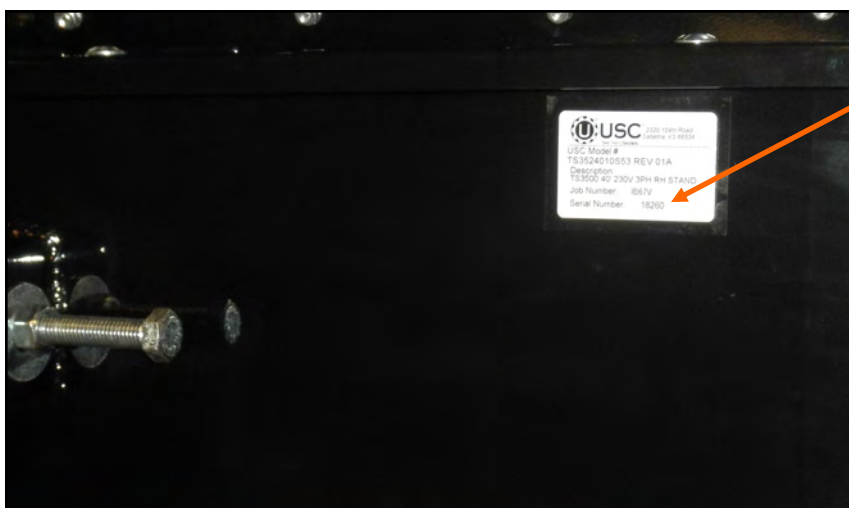

*Serial
Number*

SERIAL NUMBER: _____

TABLE OF CONTENTS

<u>Section</u>	<u>Contents</u>	<u>Page #</u>
Section A	Safety Instructions	5
Section B	Installation	19
	Assembling Undercarriage	20
	Installing Undercarriage	22
	Installing Winch and cable	24
Section C	Mechanical Operation	26
	System Overview	27
	Controls	28
	Pre-Operation Checklist	29
	Conveyor Set Up	30
	Operation	31
	Machine Break-in	32
	Emergency Stopping	33
Section D	Transporting	34
Section E	Troubleshooting	36
Section F	Maintenance	37
Section G	Belt Tensioning Specification	43
Section H	Storage	44
Section I	Mechanical Drawings	45
Section J	Limited Warranty	73

SAFETY INSTRUCTIONS

SECTION A

Every year accidents in the work place maim, kill and injure people. Although it may be impossible to prevent all accidents, with the right combination of training, operating practices, safety devices, and operator vigilance, the number of accidents can be significantly reduced. The purpose of this section is to educate equipment users about hazards, unsafe practices, and recommended hazard avoidance techniques.

If any of the required regularly scheduled maintenance is located above the reach of the operator, they should follow the companies normal safe practices of reaching that particular height, utilizing the companies specified equipment and following normal safety precautions.

When working with treatment chemicals, operators should always wear protective gloves, safety glasses, and follow the companies safety precautions in the case of any spillage or operator contamination.

SAFETY WORDS AND SYMBOLS

It is very important that operators and maintenance personnel understand the words and symbols that are used to communicate safety information. Safety words, their meaning and format, have been standardized for U.S. manufacturers and published by the American National Standards Institute (ANSI). The European Community (E.C.) has adopted a different format based on the International Standards Organization (I.S.O.) and applicable machinery directives. Both formats are presented below. Graphic symbols are not standardized, but most manufacturers will use some variation of the ones seen in this manual.

MOTS ET SYMBOLES SÉCURITÉ

Il est très important que les opérateurs et le personnel d'entretien à comprendre les mots et les symboles qui sont utilisés pour communiquer des informations de sécurité. Mots de sécurité, de leur signification et le format, ont été normalisés pour les fabricants américains et publié par l' American National Standards Institute (ANSI). La Communauté européenne (CE) a adopté un format différent sur la base de l'Organisation internationale de normalisation (ISO) et des directives de machines applicables. Les deux formats sont présentés ci-dessous. Les symboles graphiques ne sont pas standardisés, mais la plupart des fabricants utilisent une variante de ceux observés dans ce manuel.



Indicates an imminently hazardous situation which, if not avoided, **will** result in death or serious injury.



Indique une situation extrêmement dangereuse qui, si pas évitée, entraînera la mort ou des blessures graves.



Indicates a potentially hazardous situation which, if not avoided, **could** result in death or serious injury.



Indique une situation potentiellement dangereuse qui, si pas évitée, pourrait entraîner la mort ou des blessures graves.



Indicates a potentially hazardous situation which, if not avoided, **may** result in minor or moderate injury and/or property damage.



Indique une situation potentiellement dangereuse qui, si pas évitée, peut entraîner des blessures mineures ou modérées et / ou des dommages.



Provides additional information that the operator needs to be aware of to avoid a potentially hazardous situation.



Fournit des informations supplémentaires que l'opérateur doit être conscient de d'éviter une situation potentiellement dangereuse.



Notice is used to notify people of important installation, operation or maintenance information which is not hazard related.



Avis est utilisé pour informer les gens des informations de maintenance qui ne est pas danger lié importante installation, l'exploitation ou.



Mandatory Lockout Power Symbol. Disconnect, lockout and tag-out electrical and other energy sources before inspecting, cleaning or performing maintenance on this panel.

Symbole de puissance verrouillage obligatoire. Débranchez, de verrouillage et de désignation énergie électrique et d'autres sources avant d'inspecter, de nettoyage ou de la maintenance de ce panneau.



International Safety Alert Symbol. The exclamation point (!) surrounded by a yellow triangle indicates that an injury hazard exists. However, it does not indicate the seriousness of potential injury. The exclamation point (!) is also used with the DANGER, WARNING and CAUTION symbols so the potential injury is indicated.

Sécurité Symbole International Alert . Le point d'exclamation (!) Entouré par un triangle jaune indique que un risque de blessure existe . Cependant, il ne indique pas la gravité des blessures potentielles. Le point d'exclamation (!) Est également utilisé avec les symboles DANGER, AVERTISSEMENT et ATTENTION de sorte que le risque de blessure est indiqué.



Electrocution Hazard Symbol. This symbol indicates that an electrocution hazard exists. Serious injury or death could result from contacting high voltage.

Symbole de danger d'électrocution . Ce symbole indique qu'un danger d'électrocution existe. Des blessures graves ou la mort pourraient résulter de contact haute tension.



International Electrocution Hazard. This symbol indicates that an electrocution hazard exists. Serious injury or death could result from contacting high voltage.

Danger d'électrocution international. Ce symbole indique qu'un danger d'électrocution existe. Des blessures graves ou la mort pourraient résulter de contact haute tension.



Mandatory Read Manual Action Symbol. (I.S.O. format) This symbol instructs personnel to read the Operators Manual before servicing or operating the equipment.

Obligatoire Lire Symbole d'action Manuel. (Format ISO)
Ce symbole indique le personnel de lire le manuel de l'opérateur avant de réparer ou d'utiliser l'équipement.



Mandatory Read Manual Action Symbol. This symbol instructs personnel to read the Operators Manual before servicing or operating the equipment.

Obligatoire Lire Symbole d'action Manuel . Ce symbole indique le personnel de lire le manuel de l'opérateur avant de réparer ou d'utiliser l'équipement.

LOCKOUT / TAGOUT PROCEDURES

Lockout/Tagout is the placement of a lock/tag on an energy isolating device in accordance with an established procedure. When taking equipment out of service to perform maintenance or repair work, always follow the lockout / tagout procedures as outlined in ANSI Z344.1 and/or OSHA Standard 1910.147. This standard “requires employers to establish a program and utilize procedures for affixing appropriate lockout devices or tagout devices to energy isolating devices and to otherwise disable machines or equipment to prevent unexpected energizing, start-up, or release of stored energy in order to prevent injury to employees.”

LES PROCEDURES DE VERROUILLAGE / ETIQUETAGE

Verrouillage / étiquetage est le placement d'un verrouillage / tag sur un dispositif d'isolement de l'énergie conformément à une procédure établie. Lors de la prise hors service des équipements pour effectuer la maintenance ou de réparation, toujours suivre les procédures de verrouillage / débranchement comme indiqué dans la norme ANSI Z344.1 et / ou la norme OSHA 1910.147. Cette norme "oblige les employeurs à établir un programme et appliquer des procédures pour la fixation des dispositifs de verrouillage appropriés ou des dispositifs déconsignation à l'énergie dispositifs d'isolement et d' autre machines ou équipements désactiver pour éviter énergisant inattendu, start-up, ou la libération de l'énergie stockée dans le but de prévenir les blessures aux employés."

HAZARD REVIEW

RISQUE EXAMEN

Electrocution Hazard



Electrocution accidents are most likely to occur during maintenance of the electrical system or when working on or near exposed high voltage wiring. This hazard does not exist when the electrical power has been disconnected, properly locked, and tagged out.

Risque d'électrocution

Les accidents d'électrocution sont les plus susceptibles de se produire lors de la maintenance du système électrique ou pour travailler sur ou à proximité du câblage haute tension exposé. Ne existe pas ce danger lorsque l'alimentation électrique a été déconnecté, bien verrouillé et étiquetés sur.

Automatic Start Hazard



! WARNING

This equipment may be controlled by an automated system and may start without warning. Failure to properly disconnect, lockout, and tagout all energy sources of remotely controlled equipment creates a very hazardous situation and could cause injury or even death. PLEASE STAY CLEAR AND BE ALERT.

Démarrer danger automatique

! AVERTISSEMENT

Cet équipement peut être contrôlé par un système automatisé et peut démarrer sans avertissement. Sources de l'équipement contrôlé à distance non débranché correctement, lock-out, et tous déconsignation énergie crée une situation très dangereuse et pourrait causer des blessures ou même la mort. Se IL VOUS PLAÎT rester à l'écart et d'être vigilant.

YOU are responsible for the **SAFE** operation and maintenance of your equipment . **YOU** must ensure that you and anyone else who is going to operate, maintain, or work around the conveyor be familiar with the operating and maintenance procedures and related **SAFETY** information contained in this manual. This manual will take you step-by-step through your working day and alert you to good safety practices that should be adhered to while operating the conveyor.

Remember, **YOU** are the key to safety. Good safety practices not only protect you, but also the people around you. Make these practices a working part of your safety program. Be certain that **EVERYONE** operating this equipment is familiar with the recommended operating and maintenance procedures and follows all the safety precautions. Most accidents can be prevented. Do not risk injury or death by ignoring good safety practices.

- Equipment owners must give operating instructions to operators or employees before allowing them to operate the machine, and at least annually thereafter per OSHA (Occupational Safety and Health Administration) regulation 1928.57.
- The most important safety device on this equipment is a **SAFE** operator. It is the operator's responsibility to read and understand **ALL** Safety and Operating instructions in the manual and to follow them. All accidents can be avoided.
- A person who has not read and understood all operating and safety instructions is not qualified to operate the machine. An untrained operator exposes himself and bystanders to possible serious injury or death.
- Do not modify the equipment in any way. Unauthorized modification may impair the function and/or safety and could affect the life of the equipment.
- Think SAFETY! Work SAFELY!

GENERAL SAFETY

1. Read and understand the Operator's Manual and all safety signs before operating, maintaining, adjusting or unplugging the Equipment .
2. Only trained persons shall operate the conveyor. An untrained operator is not qualified to operate the machine.
3. Have a first-aid kit available for use should the need arise, and know how to use it.



SEED SERIES 16 CONVEYOR

4. Provide a fire extinguisher for use in case of an accident. Store in a highly visible place.
5. Do not allow children, spectators or bystanders within hazard area of machine.
6. Wear appropriate protective gear. This includes but is not limited to:
 - A hard hat
 - Protective shoes with slip resistant soles
 - Protective goggles
 - Heavy gloves
 - Hearing protection
 - Respirator or filter mask
7. Place all controls in neutral or off, stop motor, and wait for all moving parts to stop. Then disable power source before servicing, adjusting, repairing, or unplugging.
8. Review safety related items annually with all personnel who will be operating or maintaining the Semi - Automated Pump Stand.



OPERATING SAFETY:

1. Read and understand the Operator's Manual and all safety signs before using.
2. Disconnect and disable electrical supply completely and wait for all moving parts to stop before servicing, adjusting, repairing or unplugging.
3. Clear the area of bystanders, especially children, before starting.
4. Be familiar with the machine hazard area. If anyone enters hazard area, shut down machine immediately. Clear the area before restarting.
5. Keep hands, feet, hair and clothing away from all moving and/or rotating parts.
6. Stay away from overhead obstructions and power lines during operation and transporting. Electrocutation can occur without direct contact.
7. Do not operate machine when any guards are removed.
8. Inspect welds and repair if needed.

TRANSPORT SAFETY

1. Read and understand ALL the information in the Operator's Manuals regarding procedures and SAFETY when moving or transporting the Conveyor.
2. Check with local authorities regarding Conveyor transport on public roads. Obey all applicable laws and regulations.
3. Always travel at a safe speed. Use caution when making corners or meeting traffic.
4. Make sure the SMV (Slow Moving Vehicle) emblem and all the lights and reflectors that are required by the local highway and transport authorities are in place, are clean and can be seen clearly by all overtaking and oncoming traffic.
5. Do not allow riders on the Conveyor or the towing vehicle when transporting.
6. Attach Conveyor to towing vehicle with a pin and retainer.
7. Lower Conveyor to its lowest position for transporting. Keep lift point at drawbar height.
8. Keep to the right and yield the right-of-way to allow faster traffic to pass. Drive on the road shoulder, if permitted by law.
9. Do not exceed 25 m.p.h. (40 km/h). Reduce speed on rough roads and surfaces.
10. Stay away from overhead obstructions and power lines when transporting. Electrocutation can occur without direct contact.
11. Always use hazard warning flashers on tractor when transporting unless prohibited by law.

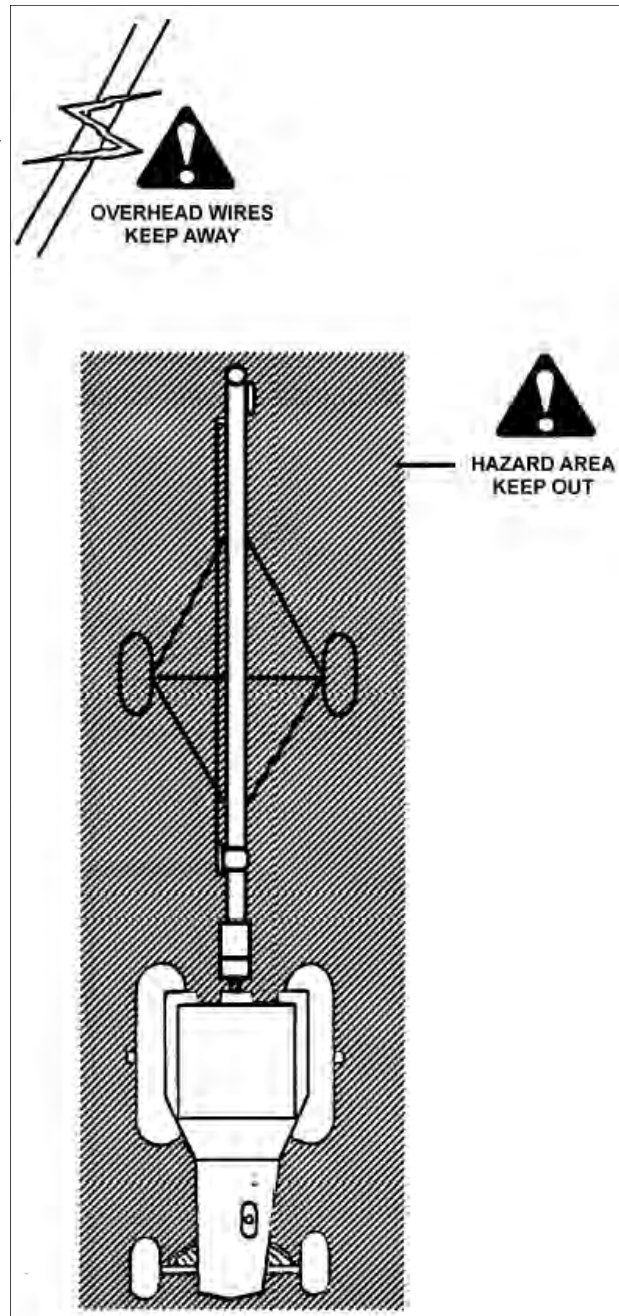

PLACEMENT SAFETY

1. Move only with the appropriate equipment
2. Stay away from overhead power lines when moving the Conveyor. Electrocution can occur without direct contact.
3. Be familiar with machine hazard area. If anyone enters hazard areas, shut down machine immediately. Clear the area before restarting.
4. Operate the Conveyor on level ground free of debris. Anchor the Conveyor to prevent tipping or upending.



Before placement of the Conveyor, be sure that ground is reasonably level. The Conveyor may topple or work improperly if the ground is too uneven, damaging the equipment and/or causing personal injury.

! AVERTISSEMENT

Avant le placement du Convoyeur, être sûr que sol est relativement plat. Le convoyeur peut renverser ou un mauvais fonctionnement si le sol est trop inégale, endommager l'équipement et / ou causer des blessures.



When releasing the Conveyor from the towing vehicle, test the intake end for downward weight. Do not raise the intake end above drawbar height. When the intake end is elevated too high with machine in raise position, the balance of weight quickly transfers to the discharge end.

! AVERTISSEMENT

En relâchant le convoyeur par rapport au véhicule de remorquage, de tester l'extrémité d'entrée pour le poids vers le bas. Ne pas lever l'extrémité d'entrée ci-dessus hauteur du timon. Lorsque l'extrémité d'admission est élevée trop haut avec la machine en position de relance, l'équilibre de poids transfère rapidement à l'extrémité de décharge.

TIRE SAFETY

1. Failure to follow proper procedures when mounting a tire on a wheel or rim can produce an explosion which may result in serious injury or death.
2. Do not attempt to mount a tire unless you have the proper equipment and experience to do the job.
3. Have a qualified tire dealer or repair service perform required tire maintenance.
4. When replacing worn tires, make sure they meet the original tire specifications. Never undersize.

MAINTENANCE SAFETY

1. Review the Operator's Manual and all safety items before working with, maintaining or operating the Conveyor.
2. Place all controls in neutral or off, stop motors, disable power source, and wait for all moving parts to stop before servicing, adjusting, repairing or unplugging.
3. Follow good shop practices:
Keep service area clean and dry.
Be sure electrical outlets and tools are properly grounded.
Use adequate light for the job at hand.
4. Keep hands, feet, hair and clothing away from all moving and/or rotating parts.
5. Clear the area of bystanders, especially children, when carrying out any maintenance and repairs or making any adjustments.
6. Before resuming work, install and secure all guards when maintenance work is completed.
7. Keep safety signs clean. Replace any sign that is damaged or not clearly visible.



SAFETY LABELS

1. Keep safety labels clean and legible at all times.
2. Replace safety labels that are missing or have become illegible.
3. Replaced parts that displayed a safety label should also display the current label.
4. Replacement safety labels are available. Contact USC at (785) 431-7900 .

How to Install Safety Labels:

- Be sure that the installation area is clean and dry.
- Be sure temperature is above 50°F (10°C).
- Decide on the exact position before you remove the backing paper.
- Remove the smallest portion of the split backing paper.
- Align the sign over the specified area and carefully press the small portion with the exposed sticky backing in place.
- Slowly peel back the remaining paper and carefully smooth the remaining portion of the sign in place.
- Small air pockets can be pierced with a pin and smoothed out using the piece of sign backing paper.



Located on the USC equipment you will find safety labels. Always be sure to read and follow all directions on the labels.



Situé sur l'équipement USC vous trouverez des étiquettes de sécurité. Veuillez à toujours lire et suivre toutes les instructions sur les étiquettes.



Guards provided with USC equipment are to remain in place during operation.



Gardes fournis avec des équipements USC doivent rester en place pendant le fonctionnement.

Think **SAFETY!** Work **SAFELY!**

REMEMBER—If Safety Labels have been damaged, removed, become illegible, or parts replaced without safety labels, new labels must be applied. New safety labels are available from USC at (785) 431-7900.



Part # 09-02-0008



Part # 09-02-0009

SEED SERIES 16 CONVEYOR



CAUTION

1. Read and understand the Operator's Manual before operating.
2. Keep all safety shields and devices in place and in good working order.
3. Make certain everyone is clear before operating or moving the machine. Keep children, visitors and untrained people away.
4. Keep hands, feet, hair and clothing away from moving parts.
5. Shut off and disable power source before adjusting, servicing, repair, or cleaning.
6. Disconnect power before resetting motor overload.
7. Be sure electric motors are grounded.
8. Support discharge end or anchor intake end to prevent upending.
9. Empty Conveyor before moving to prevent upending.
10. Lower conveyor to its fully down position before moving or transporting. Use a tractor to move and transport.
11. Lower Conveyor well below level of power lines before moving or transporting. Electrocutation can occur without direct contact.
12. Keep away from intake. Keep others away.
13. Train operators annually.

09-02-0006

Part # 09-02-0006

DANGER

ELECTROCUTION HAZARD
KEEP AWAY FROM POWER LINES
 To prevent serious injury or death from electrocution:

1. Stay well away from power lines. Electrocutation can occur without direct contact.
2. Lower Conveyor well below level of power line before moving or transporting.

09-02-0007

Part # 09-02-0007

WARNING

MOVING PART HAZARD
 To prevent serious injury or death from falling:

1. Do not stand or climb on machine when operating. Keep others off.
2. Keep hands, feet, and hair away from moving parts.
3. Wear tight clothing and safety gear.

09-02-0011

Part # 09-02-0011

SEED SERIES 16 CONVEYOR

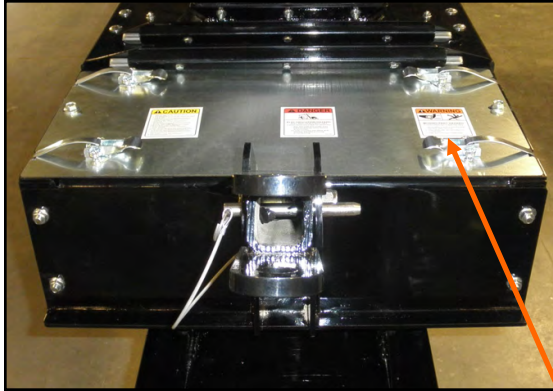

Part # 09-02-0011

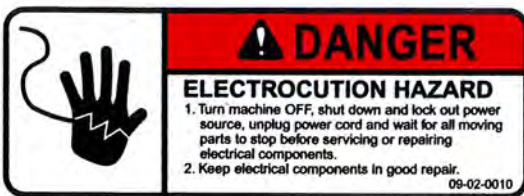
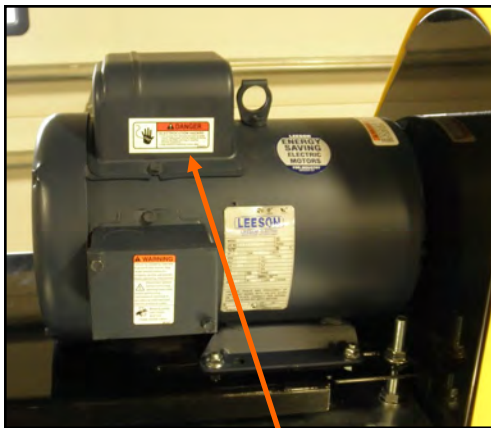

Part # 09-02-0010



Part # 09-02-0012

INSTALLATION**SECTION
B**

HIGH VOLTAGE ~ Always disconnect the power source before working on or near the control panel or lead wires.



HAUTE TENSION ~ Toujours débrancher la source d'alimentation avant de travailler sur ou près du panneau de commande ou les câbles.



HIGH VOLTAGE ~ Use insulated tools when making adjustments while the controls are under power.



HAUTE TENSION ~ Utilisez des outils isolés lors des réglages, tandis que les commandes sont sous tension.



Permanent installation may require additional electrical cords, chemical tubing, and air lines, since each installation is unique.



Installation permanente peut exiger cordons électriques, des tubes supplémentaires chimique, et les conduites d'air, puisque chaque installation est.

USC equipment may operate within a Group II, Division 2, Class G hazardous area which contains seed dust. If so, the equipment must be certified for use in this area. To avoid the possibility of an explosion ignited by static electricity, all USC equipment should be grounded by attaching a bonding strip to the metal frame and securing that strip to the factory ground point.

If labeled accordingly, USC products are designed to comply with CSA 22.1 for use in a Class II, Division 2, Group G environment. When connecting the USC system power cord into a power supply, first determine if the supply is also within the hazardous area where the USC system is located. If so, we recommend that the power be hard wired into the source. Do not use a standard electrical plug for this purpose. For other acceptable methods of connecting to a power source, or any other additional miscellaneous equipment to the USC system within a hazardous location, please consult CSA 22.1, Section 18-200 and 18-274. Review the appropriate section and ensure compliance with one of the options given.

When connecting to USC equipment from a remote location, and the USC equipment is in a hazardous Class II, Group G environment, customers are advised to follow the requirements within CSA 22.2 no. 25. More details may also be found in CSA 22.1 18-252 (wiring methods). There are various options covered within this section for wiring in a Class II, Group G (dust) environment. Select the best method suited for your specific location.

équipements USC peut fonctionner dans un Groupe II, Division 2, Classe G zone dangereuse qui contient la poussière des semences. Si oui, l'équipement doit être certifié pour une utilisation dans ce domaine. Pour éviter la possibilité d'une explosion enflammé par l'électricité statique, tous les équipements USC doit être mis à la terre en attachant une bande de liaison à la structure métallique et la sécurisation cette bande au point de masse du fabricant.

Si étiquetés en conséquence, les produits USC sont conçus pour être conformes à la norme CSA 22.1 pour une utilisation dans une Classe II, Division 2, Groupe G environnement. Lors du raccordement du USC alimentation du système cordon dans une alimentation, d'abord déterminer si l'offre est également dans la zone dangereuse où se trouve le système USC. Si oui, nous recommandons que le pouvoir soit câblé dans la source. Ne pas utiliser une prise électrique standard à cet effet. Pour les autres méthodes acceptables de se connecter à une source d'alimentation, ou tout autre matériel divers supplémentaire au système USC dans un endroit dangereux, se il vous plaît consulter la norme CSA 22.1, Section 18-200 et 18-274. Consultez la section appropriée et assurer la conformité avec l'une des options proposées.

Lors de la connexion à l'équipement USC depuis un emplacement distant et l'équipement USC est dans une classe dangereuse II, Groupe G environnement, les clients sont invités à suivre les exigences dans CSA 22.2 no. 25. Plus de détails peuvent également être trouvés dans 22,1 CSA 18-252 (Les méthodes de câblage). Il existe diverses options couvertes dans cette section pour le câblage dans une Classe II, Groupe G (poussière) environnement. Sélectionnez la meilleure méthode adaptée pour votre emplacement spécifique.

The following instructions should be used to assemble your USC conveyor undercarriage. Hand tighten all fasteners until undercarriage is completely assembled.

1. Lay the Axle flat on the ground **(A)**.
2. Mount both tires **(B)**.
3. Assemble the upper arm weldments to the axle **(C)**.
4. Assemble the upper cross member to both arms. Make sure you use the one with two pulleys on it **(D)**.
5. Attach the upper cross braces **(E)**.
6. Using the upper arm pin, assemble the Transport Slide **(F)**.
7. Assemble the lower arm weldments to the axle **(G)**.
8. Assemble the lower cross member to both arms. Make sure you use the one with one pulley **(H)**.
9. Attach the lower cross braces **(I)**.
10. Tighten all of the fasteners.

SEED SERIES 16 CONVEYOR
ASSEMBLING UNDER-CARRIAGE

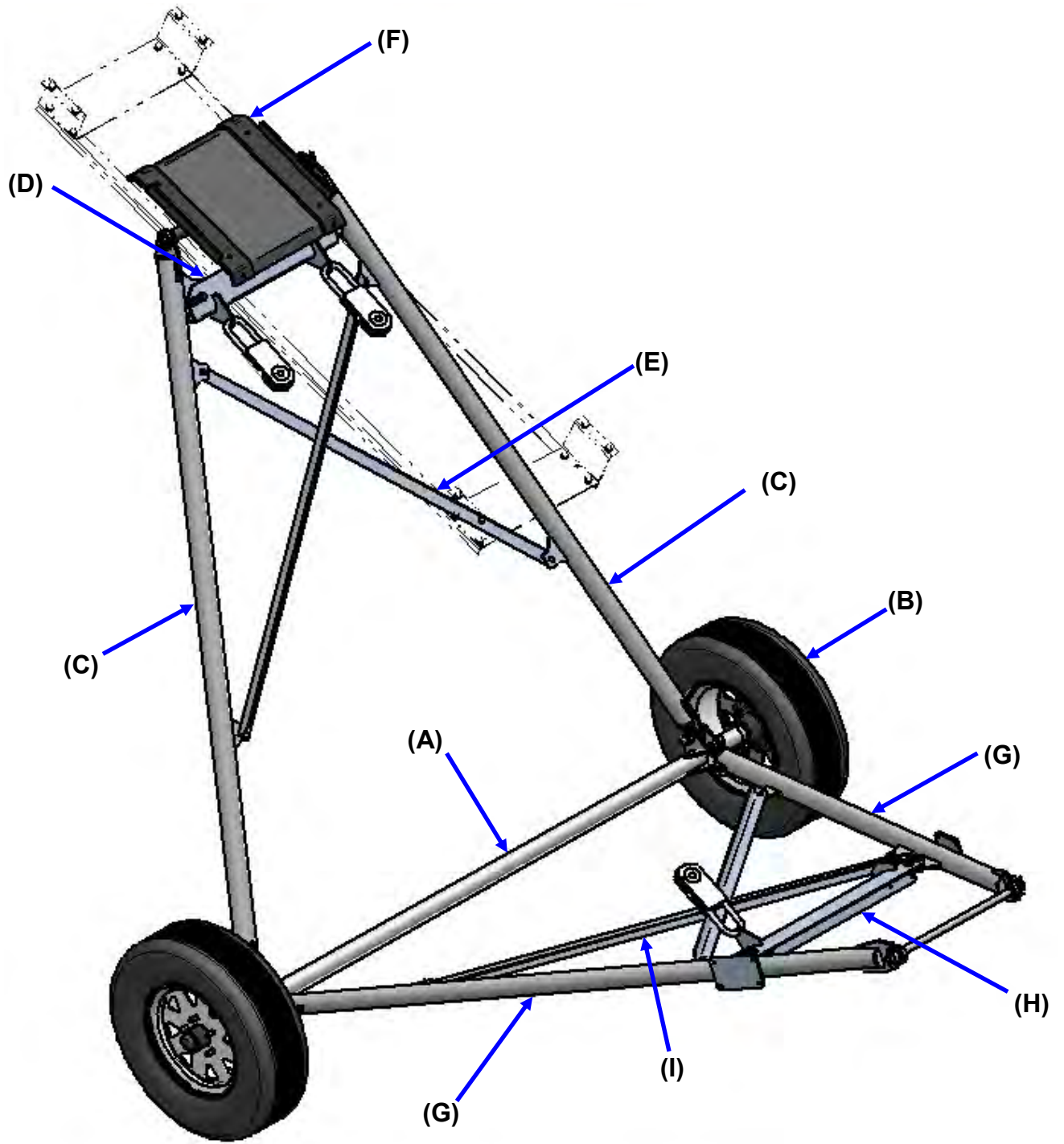

INSTALLING UNDER-CARRIAGE

1. Using a forklift, pick up the conveyor in the center. Move conveyor over the assembled undercarriage centering it.
2. Remove the angle supports from the slide stops. Place the slide in between the two slide stops. Re-install the angle supports capturing the slide.

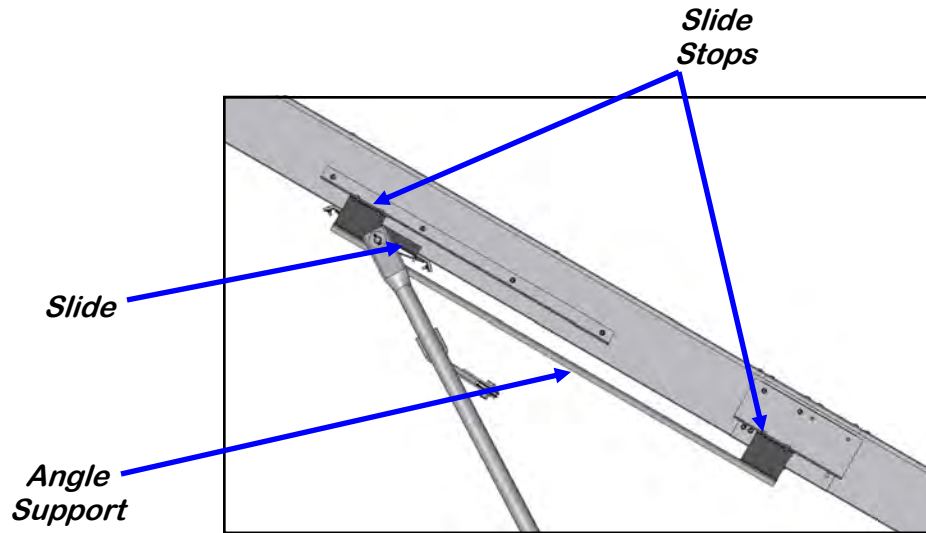

3. Using the lower arm pin, assemble the lower arms to the bottom bracket on the conveyor. For the 20 and 25 foot conveyor, use the hole closest to the inlet end and for the 30 and 35 foot use the hole farthest away from the inlet end.

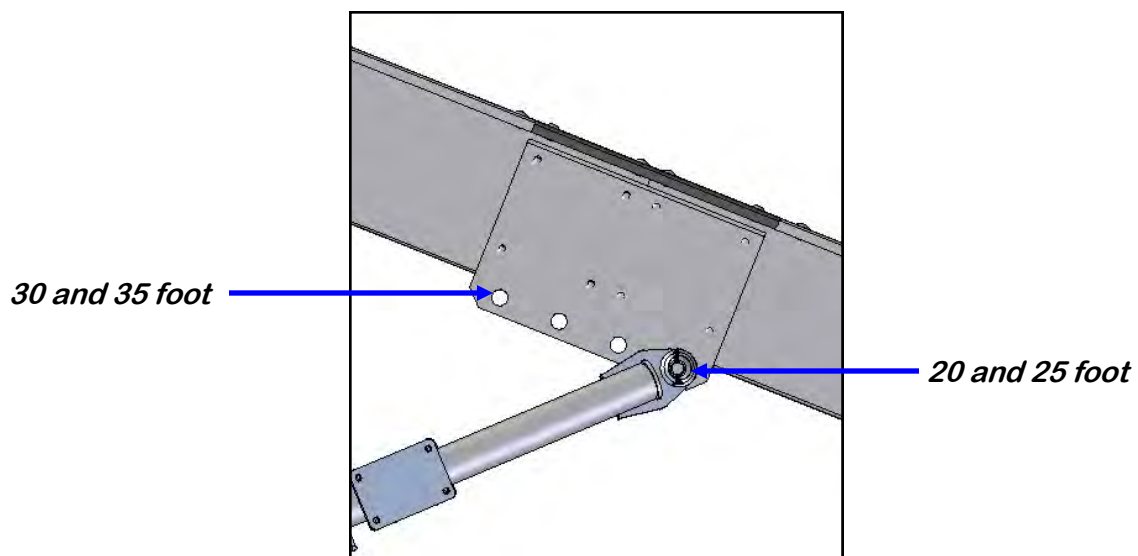

INSTALLING UNDER-CARRIAGE

4. Assemble the Hitch Assembly and Conveyor Pad. Lower the entire assembly and set down the inlet side on the conveyor pad.

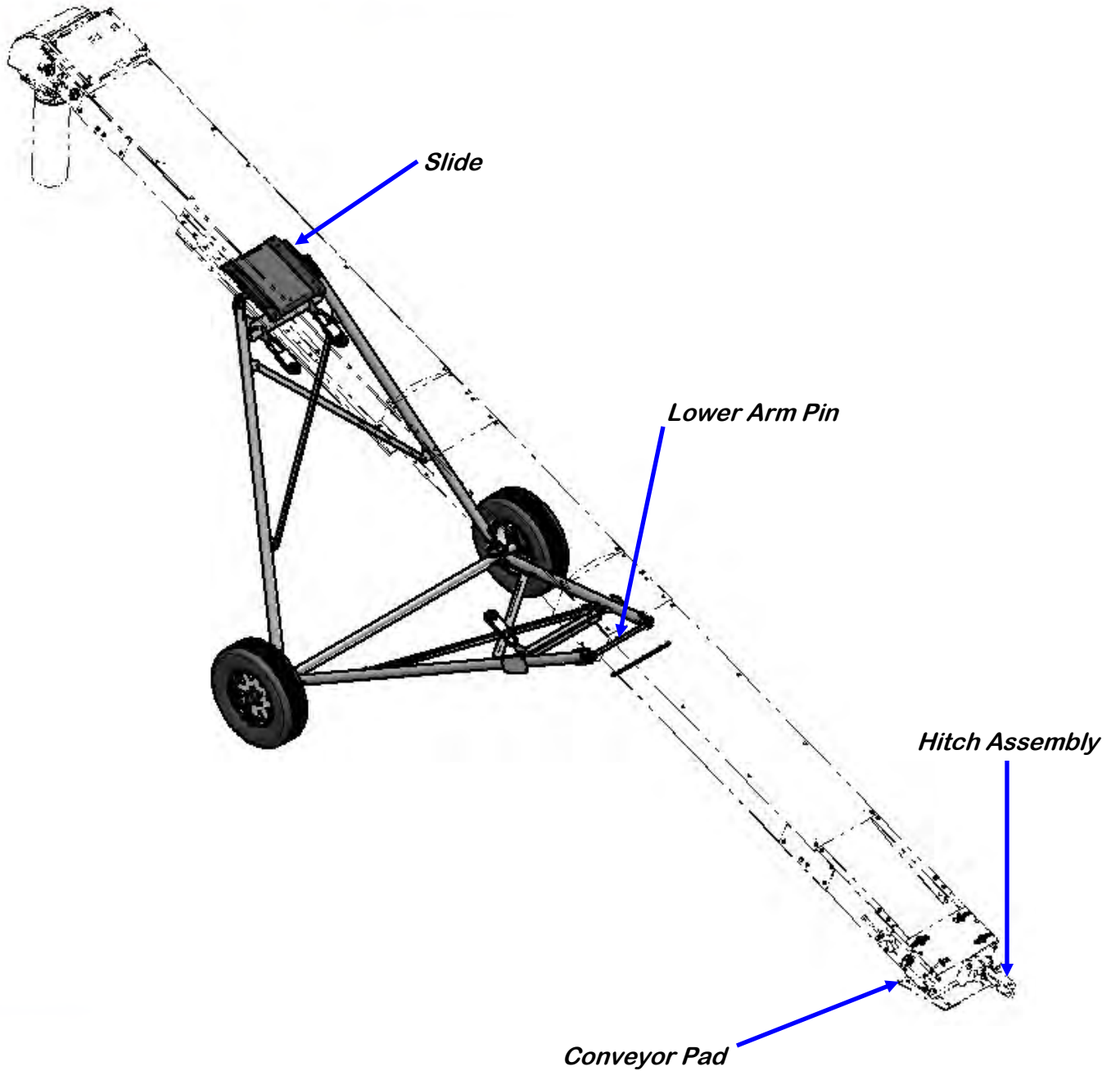

INSTALLING WINCH and CABLE

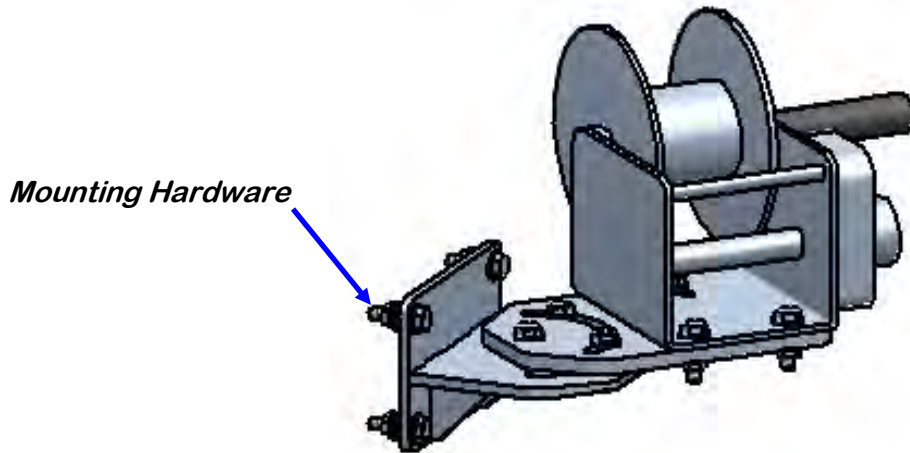

WINCH ASSEMBLY DETAIL

1. Attach the winch to the lower arm using the hardware provided (above).
2. Attach the cable to the crank.
3. String the cable through the pulleys and attach to the under-carriage following the path as shown in the illustration on page 25.
4. After cable has been run through the pulleys as shown, terminate at the lower cross member as shown below.

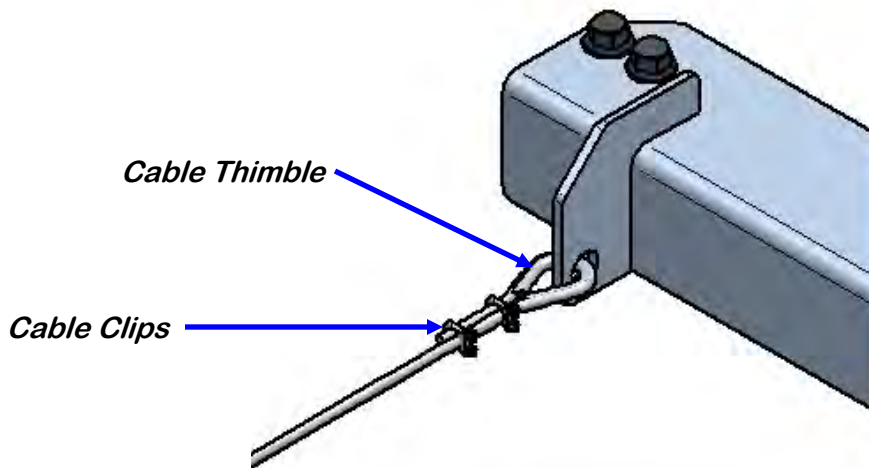

CABLE ANCHOR DETAIL

INSTALLING WINCH and CABLE



TYPICAL CABLE ROUTING

SECTION
C**MECHANICAL OPERATION****OPERATING SAFETY**

1. Read and understand the Operator's Manual and all safety signs before using.
2. Electric motor drives: Disconnect and disable electrical supply completely and wait for all moving parts to stop before servicing, adjusting, repairing or unplugging.
3. Clear the area of bystanders, especially children, before starting.
4. Be familiar with machine hazard area. If anyone enters hazard areas, shut down machine immediately. Clear the area before restarting.
5. Keep hands, feet, hair and clothing away from all moving and/or rotating parts.
6. Do not allow riders on the Conveyor or transport vehicle when transporting.
7. Stay away from overhead obstructions and power lines during operation and transporting. Electro-cution can occur without direct contact.
8. Do not operate machine when any guards are removed.
9. Lower Conveyor to its lowest position before moving or transporting or when not in use.
10. Inspect lift cable before using Conveyor. Replace if frayed or damaged.
11. Make certain lift cable is properly seated in cable pulleys.
12. Be sure that conveyor is empty before raising or lowering.

The Seed Series Conveyor is designed to efficiently move seed between a storage facility or seed totes and a truck, trailer or seed treater. Power is provided by an electric motor. Be familiar with the machine before starting.

It is the responsibility of the owner or operator to read this manual and to train all other operators before they start working with the machine. In addition to the design and configuration of equipment, hazard control and accident prevention are dependent upon the awareness, concern, and prudence of personnel involved in the operation, transport, maintenance and storage of equipment or in the use and maintenance of facilities.

NOTICE

Follow all safety instructions exactly. Safety is everyone's business. By following recommended procedures, a safe working environment is provided for the operator, bystanders and the area around the worksite. Untrained operators are not qualified to operate the machine.

AVIS

Suivez toutes les instructions de sécurité à la lettre. La sécurité est l'affaire de tous. En suivant les procédures recommandées, un environnement de travail sécuritaire pour l'opérateur, les passants et la zone autour du chantier. Opérateurs non formés ne sont pas qualifiés pour faire fonctionner la machine.

Many features incorporated into this machine are the result of suggestions made by customers like you. Read this manual carefully to learn how to operate the machine safely and how to set it to provide maximum efficiency. By following the operating instructions in conjunction with a good maintenance program, your conveyor will provide many years of trouble-free service.

SEED SERIES 16 CONVEYOR

SYSTEM OVERVIEW

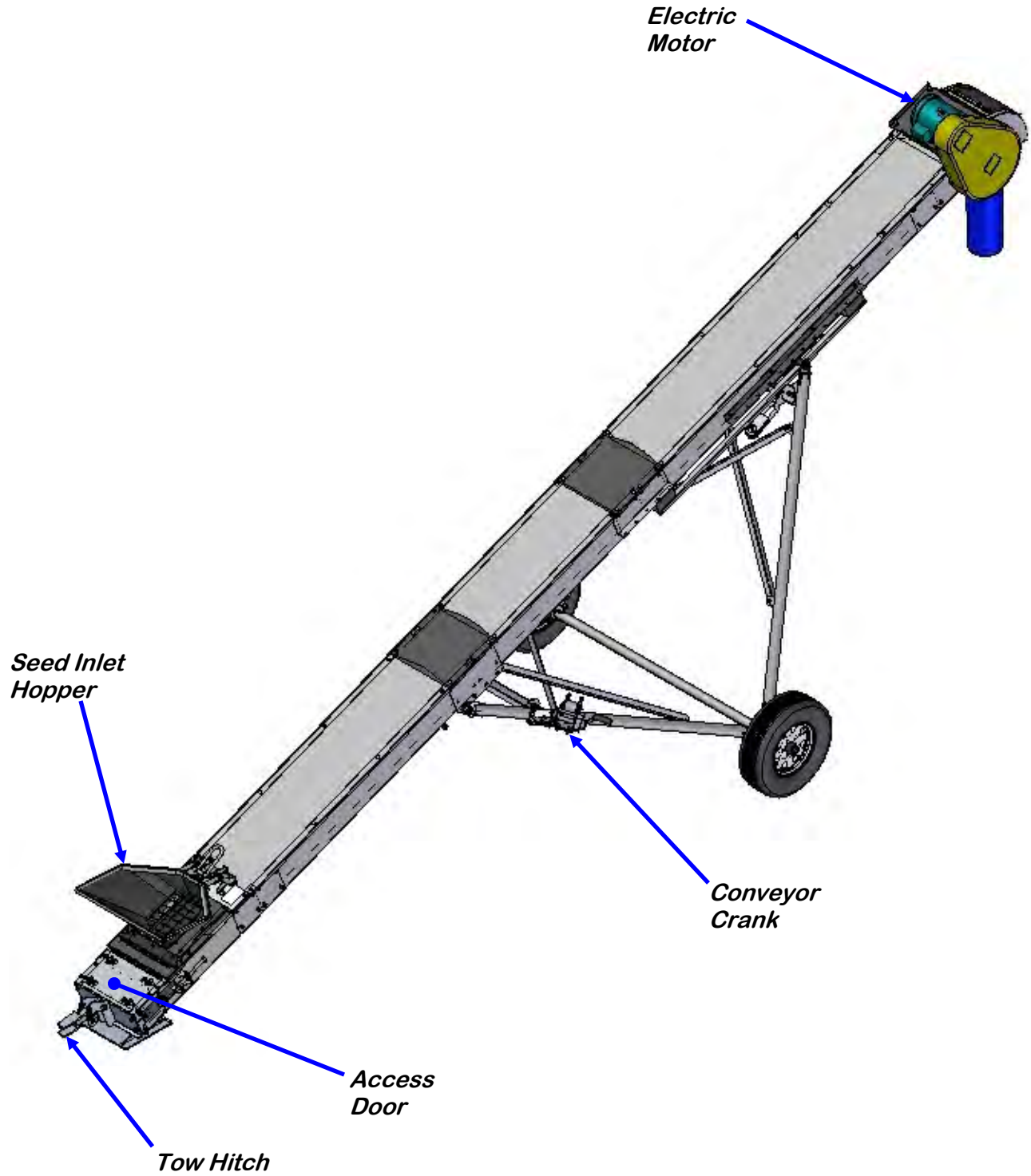

CONTROLS

- **Electric Drive:** Have a licensed electrician provide power to the motor per the National Electrical Code ANSI/NFPA 70 and local codes. Install an ON, OFF switch for the convenience of the operator.
- **Manual Winch:** A winch is located on the transport frame and is used to raise and lower the conveyor. Turn the handle clockwise to raise and counterclockwise to lower.

⚠ WARNING

Maintain at least 3 wraps of cable on the drum at the maximum reach. The drum cable clamp is not designed to hold load.

! AVERTISSEMENT

Maintenir au moins trois enroulements de câble sur le tambour à la portée maximale. Le serre-câble de batterie ne est pas conçu pour tenir la charge.

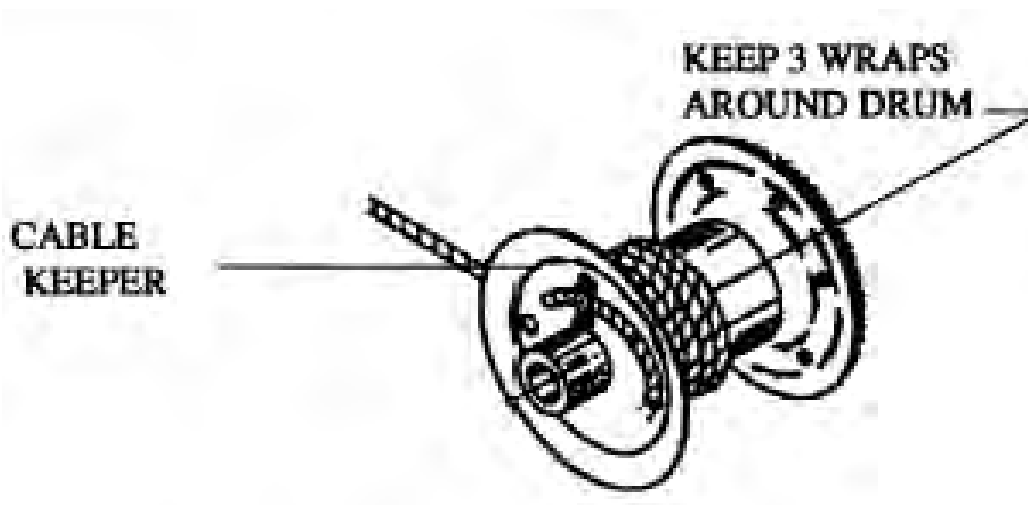

PRE-OPERATION CHECKLIST

Efficient and safe operation of the Seed Series Conveyor requires that each operator reads and understands the operating procedures and all related safety precautions outlined in this section. A pre-operation checklist is provided for the operator. It is important for both the personal safety and maintaining the good mechanical condition of the Conveyor that this checklist is followed.

Before operating the Conveyor and each time thereafter, the following areas should be checked off:

1. Service the machine per the schedule outlined in Section F, Maintenance. (Page 37)
2. Use only an electric motor of adequate power to operate the machine.
3. Check that all guards are installed, secured and functioning as intended. Do not operate with missing or damaged shields.
4. Check worksite. Clean up working area to prevent slipping or tripping.
5. Check winch and cable for security and operation. There should be at least 3 complete wraps of cable around winch drum in full down position. Cable anchor on winch drum must be tight. Inspect cable for fraying or damage and replace if damaged or frayed.
6. Check that cable clamps are secure.
7. Check that drive belt and conveying belt are not frayed or damaged and that they are properly adjusted and aligned.
8. Be sure Conveyor wheels are chocked.
9. Check that discharge and intake areas are free of obstructions.



Anchoring and / or support of Conveyor during operation is necessary. When the lower half of Conveyor empties of material, the weight balance transfers to the upper end of the machine, which can cause upending.

! AVERTISSEMENT

Ancrage et / ou le soutien de convoyeur pendant le fonctionnement est nécessaire. Lorsque la partie inférieure de convoyeur se vide de matière, les transferts de solde en poids à l'extrémité supérieure de la machine, ce qui peut provoquer bouleversant.

CONVEYOR SET-UP

The following steps outline the initial set-up of your Seed Series Conveyor:

1. Clear the area of bystanders, especially small children, before starting.
2. Be sure there is enough clearance from overhead obstructions and power lines or other equipment to move the machine into its working position.
3. Attach the Conveyor to an appropriate towing vehicle.
4. Move conveyor as near as possible to desired position.
5. Set the park brake on the towing vehicle before dismounting.
6. Unhook the unit from the towing vehicle.
7. Use the winch to raise the machine so it clears the truck, trailer or wagon.
8. Place chocks in the front and rear of each wheel.
9. It will be necessary to stake or weight the intake end to prevent upending when the machine is emptying.
10. Review the Workplace Safety Diagram for your model prior to starting work. Follow all setup instructions and do not allow any unauthorized people into the working area.
11. Have a certified electrician provide power to the conveyor. Provide convenient shutdown switches and comply with local electrical codes. The conveyor may also be plugged directly into a USC seed treater control panel.



Ensure that the seed treater panel and the conveyor are rated for the same power before plugging the conveyor into the seed treater panel.

! AVERTISSEMENT

Assurez-vous que le panneau de traitement des semences et le convoyeur sont prévus pour la même puissance avant de brancher le convoyeur dans le panneau de traitement des semences.

12. Reverse the above procedure when removing the machine from its working position.

OPERATION

When using the Conveyor, follow this procedure:

1. Clear the area of bystanders, especially small children, before starting.
2. Review the Pre-Operation Checklist (page 29) before starting.
3. Review the Workplace Hazards schematic and use extra care when inside the hazard area. Keep all bystanders out of this area. Should anyone enter this area, stop the machine immediately.
4. Set the conveyor in position. To achieve rated capacity, the conveyor should be run **no steeper than 30°**. Molded flights on the belt minimize material rollback during operation.
5. Drive or back the truck or wagon into position for loading.
6. Turn the electric motor ON and begin the flow of material and unload.
7. To stop the conveyor; stop the flow of material and run until the belt is empty. Turn off motor and lock out power source.

Operating hints

- Direct the flow of material into the input hopper when moving material. Do not “flood feed” the inlet hopper.
- Always listen for any unusual sounds or noises. If any are heard, stop the machine and determine the source. Correct the problem before resuming work.
- Never allow anyone into the workplace hazard area. If anyone enters, stop immediately. Make them LEAVE before resuming work.
- Do not run the machine for long periods of time with no material on the belt. It increases the wear. Try to run the conveyor only when moving material.
- Do not support the discharge end directly on the truck box, trailer or wagon. Stake the intake (hopper) or weight it down to prevent upending.
- Use a Truck Unload or similar conveyor to move grain from under the bin discharge into the Seed Series conveyor hopper when emptying low clearance facilities.

MACHINE BREAK-IN

Although there are no operational restrictions on the Conveyor when used for the first time, it is required that the following mechanical items be checked. A small amount of rubber flashing from the conveyor belt may be present during initial belt break-in period. This is part of the normal break-in process.

Before starting

1. Read the Conveyor Operator's Manual.
2. **During the conveyors first few minutes of operation, before any seed is run through, it is essential that the operator check conveyor belt tension and alignment and make any necessary adjustments (see pages 34 and 35).**

After operating or transport for 1/2 hour

1. Re-torque all the wheel bolts.
2. Re-torque fasteners and hardware.
3. Check that all safety decals are installed and legible. Apply new decals if required.
4. Check the drive belt tension and alignment. Tension or align as required.
5. Check the conveying belt tension and alignment. Tension or align as required.
6. Check that all guards are installed and working as intended.

After operating for 5 hours and 10 hours

1. Re-torque all wheel bolts, fasteners and hardware.
2. Check that all guards are installed, secured and functioning as intended. Do not operate with missing or damaged shields.
3. Check safety decals. Install new ones if required.
4. Check the drive belt, and conveying belt tension and alignment. Tension or align as required.
5. Then go to the normal servicing and maintenance schedule as defined in the Maintenance Section.

Emergency Stopping

Although it is recommended that the machine be emptied before stopping, in an emergency situation, stop or shutdown the power source immediately. Correct the emergency before resuming work.

Restarting

When the machine is shut down inadvertently or for an emergency, the belt may still be covered with material. It may be necessary to tighten the drive belt slightly to handle the heavier-than-normal starting loads.

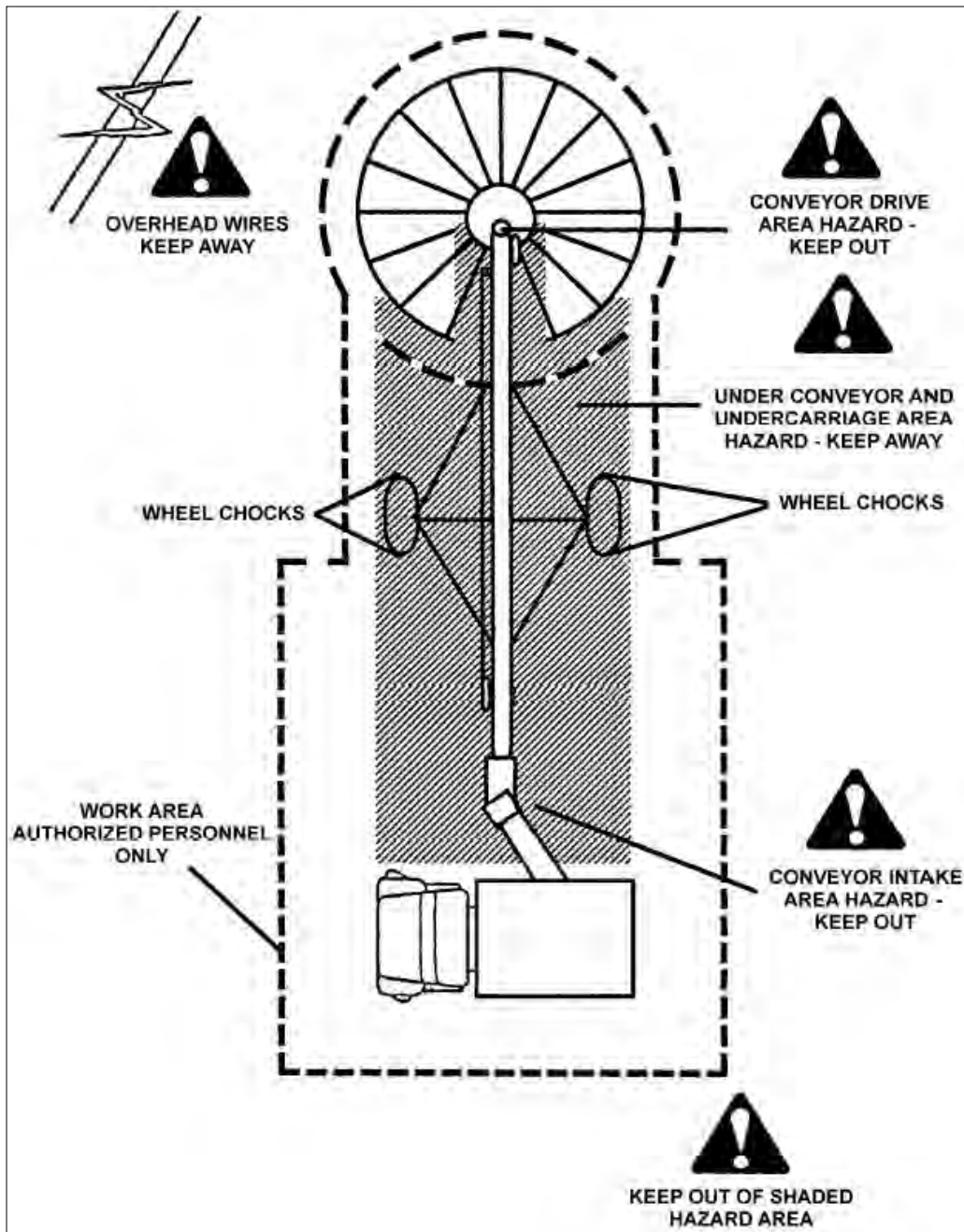

ATTACHING and UNHOOKING

It is recommended that the Conveyor be attached to an appropriate towing vehicle whenever it is moved. Follow this procedure when attaching to or unhooking from a towing vehicle:

1. Make sure that bystanders, especially small children, are clear of the working area.
2. Be sure the conveyor wheels are chocked.
3. Be sure that there is sufficient room and clearance to back up to the machine.
4. Align the drawbar of the towing vehicle with the hitch of the Conveyor while backing up.
5. Set the park brake before dismounting.
6. Lower conveyor to lowest position.
7. Place hitch pin on conveyor to the lowest hole.
8. Align the hitch to the drawbar and install a hitch pin with a retainer (not supplied).
9. Remove chocks from machine wheels.
10. Move to new location.
11. Reverse the above procedure when unhooking.
12. Removal of the most forward pin will allow the conveyor to pivot on to the hitch plate so the hitch plate can be used as a base.

TRANSPORTING

The Seed Series Conveyors are designed to be easily and conveniently moved from place to place. When transporting, follow this procedure:

1. Review the Transport Safety Schematic before starting.
2. Be sure all bystanders are clear of the machine.
3. On electric motor drive units, unplug the power cord, wrap around frame, and secure to prevent dragging.
4. Attach to a towing vehicle using a hitch pin with a retainer.
5. Remove chocks from the wheels.
6. Lower the conveyor into its fully down position so that the cross tube rests on the stop plate.
7. Electrocutation can occur without direct contact.
8. Never go across slopes of more than 20°. It is better to go straight up or straight down a slope.
9. Make sure the SMV (Slow Moving Vehicle) emblem and all the lights and reflectors that are required by the local highway and transport authorities are in place, are clean, and can be seen clearly by all overtaking and oncoming traffic.
10. Keep to the right and yield the right-of-way to allow faster traffic to pass. Drive on the road shoulder, if permitted by law.
11. It is not recommended that the machine be transported faster than 25 mph (40 km/h).
12. Do not allow riders on the machine or towing vehicle.
13. During periods of limited visibility, use pilot vehicles or add extra lights to the machine.
14. Always use hazard flashers on the vehicle when transporting unless prohibited by law.

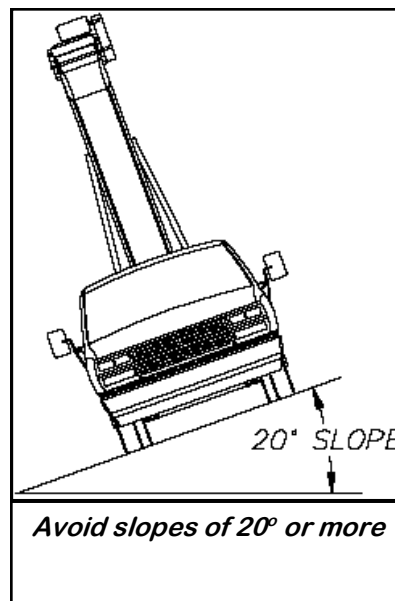
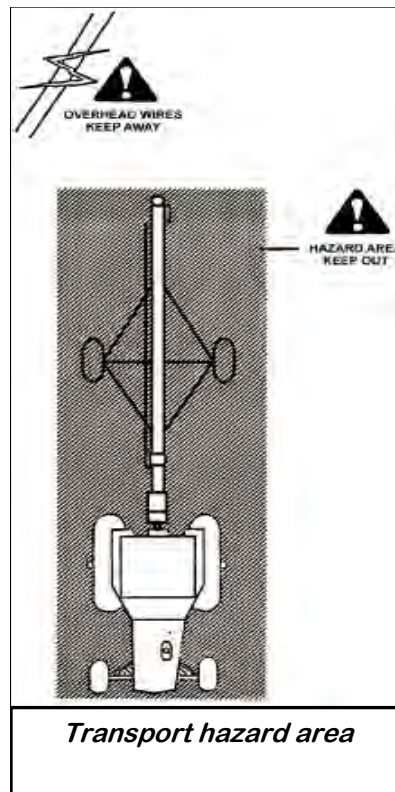

SECTION
E**TROUBLESHOOTING**

Below is a table describing the most frequent problems and solutions with the Seed Series Conveyor. For further assistance, contact your local USC at (785) 431-7900.

Problem	Possible Cause	Solution
Conveyor will not run.	<ol style="list-style-type: none"> 1. Not turned on. 2. Conveying belt loose. 3. Drive belt loose. 	<ol style="list-style-type: none"> 1. Start power source or turn on power. 2. Tighten and align belt. 3. Tighten drive belt.
Belt edge fraying.	<ol style="list-style-type: none"> 1. Belt not aligned. 	<ol style="list-style-type: none"> 1. Align and tension belt.
Low conveying capacity.	<ol style="list-style-type: none"> 1. Angle too steep. 2. Slow operating speed. 3. Conveyor belt slipping. 4. Drive belt slipping. 	<ol style="list-style-type: none"> 1. Reposition with angle at 30°. 2. Increase operating speed. 3. Tighten belt. 4. Set drive belt tension.

Unplugging

In unusual moisture or material conditions, the machine can plug. When unplugging, follow this procedure:

1. Place all controls in neutral or off, stop motor, disable and lock out power source before unplugging.
2. Unbolt and remove the necessary conveyor covers.
3. Open the tail cover.
4. Remove plugged material.
5. Install and secure conveyor and tail covers.

MAINTENANCE**SECTION
F**

Proper maintenance of the Seed Series Conveyors is critical for peak performance, reliability and accuracy of this system. The following is a guideline for the type of maintenance and servicing that should be performed on this unit. Your environment and uses may require additional maintenance and service beyond this list to assure a reliable and safe unit. The operator of this unit has ultimate responsibility to identify areas of concern and rectify them before they become a hazard or safety issue. There is no substitute for a trained, alert operator.



Do not put this unit into operation with any questionably maintained parts. Poor performance or a hazard may occur.



Ne pas mettre cet appareil en service avec des pièces douteuse entretenus. La mauvaise performance ou un danger peut survenir.



Do not use compressed air or water under pressure to clean any of the components of the USC equipment.



Ne pas utiliser d'air comprimé ou de l'eau sous pression pour nettoyer l'un des composants de l'équipement USC.

GREASING

Use an SAE multipurpose high temperature grease with extreme pressure (EP) performance. Also acceptable is an SAE multipurpose lithium-based grease.

- Use a Maintenance Checklist to keep record of all scheduled maintenance.
- Use a hand-held grease gun for all greasing.
- Wipe grease fitting with a clean cloth before greasing to avoid injecting dirt and grit.
- Replace and repair broken fittings immediately.

Storing Lubricants

Your machine can operate at top efficiency only if clean lubricants are used. Use clean containers to handle all lubricants. Store them in an area protected from dust, moisture and other contaminants.



If fittings will not take grease, remove and clean thoroughly. Also clean lubricant passageway. Replace fitting if necessary.



Si les raccords ne prendront pas la graisse, enlever et nettoyer. Aussi propre passage de lubrifiant. Remplacer approprié si nécessaire .

CONVEYOR SERVICING INTERVALS

Every 40 hours or Weekly

1. Check the conveyor belt tension and alignment.
2. Grease conveyor bearings.
 - A. Two bolt flanged bearings, tail roller bearings right and left (2 locations).
 - B. Two bolt flanged bearings, drive roller bearings right and left (2 locations).
 - C. Two bolt flanged bearings, jackshaft bearings right and left (2 locations).
3. Remove guard and check the drive belt tension and alignment. The belts will deflect approximately 1/4 to 1/2 inch when properly tensioned.
4. Check the chain tension. Adjust if required, lubricate chain and re-install guard.
5. Wipe down the motor casing with a damp cloth making sure to remove all dust that may have collected since the last maintenance date. Record the cleaning on the company required documents. If operating in a CSA 22.1, Class II, Division 2, Group G hazardous area, USC recommends this step be performed on a daily basis.
 - Essuyez le carter moteur avec un chiffon humide en veillant à éliminer toutes les poussières qui peuvent avoir perçu depuis la dernière date de maintenance. Enregistrez le nettoyage sur la société les documents requis. Si opérant dans un CSA 22.1, Classe II, Division 2, Groupe G zone dangereuse, USC recommande cette étape être effectuée sur une base quotidienne.

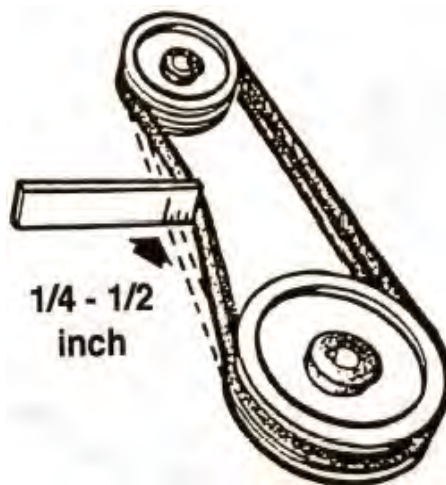

Every 200 hours or Annually

1. Repack wheel bearings.
2. Wash machine.
3. Check pulley bushing for wear. To inspect pulley:
 - A. Lower the conveyor to its lowest position.
 - B. When the conveyor has reached the lowest position, it will stop at the pins.
 - C. Unwind the winch two more turns, or until enough slack in the cable is achieved.
 - D. Loosen and remove the bolt.
 - E. Inspect the bushing on the pulley for wear.
 - F. Reverse steps A-D for re-assembly.

CONVEYING BELT TENSION AND ALIGNMENT - TAIL END

A contoured belt with molded flights is used to convey material along the frame. The tension and alignment of the belt should be checked weekly, or more often if required, to be sure that it does not slip or run to one side. A properly tensioned belt will not slip when it is operating. Operating the belt with less slippage will increase the belt life and causes less stress on bearings, pulleys and shafts.



Although it is acceptable to align the belt from either the Head or the Tail (Intake) end. Tightening the belt may only be done from the Tail end of the conveyor.



Même se il est acceptable d'aligner la courroie de la tête ou la queue (Intake) fin. Serrer la ceinture ne peut être fait à partir de la fin de queue du convoyeur.

CONVEYING BELT TENSION AND ALIGNMENT - TAIL END

To maintain the belt, follow this procedure:

NOTICE

Place all controls in neutral or off, stop motor and disable power source before working on belt.

AVIS

Placez toutes les commandes au point mort ou hors tension, arrêtez le moteur et désactivez la source d'alimentation avant de travailler sur la ceinture.

1. Use the take-up bolt located at the tail to set the tension of the belting.
2. If the belt needs to be tightened to prevent slippage, use the take-up adjustments on the tail end.
3. The belt is tightened by turning both take-up adjustments an **equal** number of turns.
4. Use the drive roller to check the alignment. The belt should be centered.
5. Turn the belt 1/2 revolution when the belt is new and check the drive and tail roller. If out of alignment, the belt will move to the loose side. Loosen the jam nut and use the bearing position bolts to set the position. Tighten jam nut.
6. Run and check again. Check frequently during the first few minutes of operation and then several times during the first 10 hours. The belt normally seats itself during the first 10 hours of operation and can be checked weekly after that.
7. The belt is properly aligned when the belt runs in the center of the head and tail rollers.

Loosen these jam nuts before adjusting the bearing position bolt

Use this bolt to tighten and align the belt

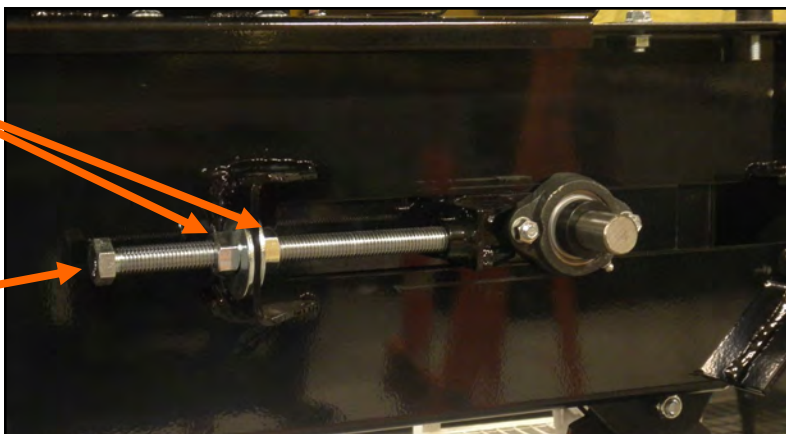

CONVEYING BELT ALIGNMENT - HEAD END

1. A misaligned belt will track toward the loose side. Set the tracking by loosening the bearing mounts on the tight side and using the bearing position bolt to move the end of the head roller toward the tail. Tighten the bearing mount when the belt is centered on the head roller.
2. Run the belt and check the tracking again. Loosen the tight side slightly again if required. Repeat the adjusting and checking procedure until the belt centers on the input end roller and remains centered when running.
3. Always repeat this aligning procedure when installing a new belt. Check frequently during the first 10 hours of operation. After 10 hours, the belt is normally seated and checking the alignment can be done less frequently.

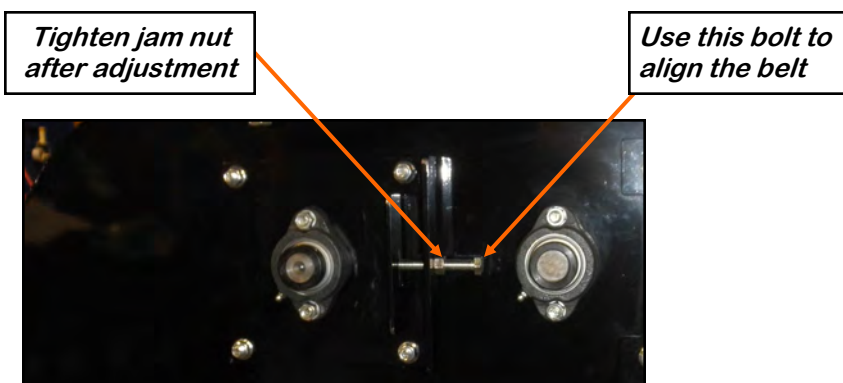

BELT REPLACEMENT

1. Rotate the belt until the seam is visible.
2. Move the tail roller to its loosest position.
3. Pull all the slack to the seam area.
4. Remove the wire connector and open the belt.
5. Attach one end of the replacement belt to the belt end being removed.
6. Pull the old belt out and the new belt will be threaded into place.
7. Disconnect the old belt.
8. Connect the ends of the new belt together and secure.
9. Set the belt tension.
10. Check and set the belt alignment

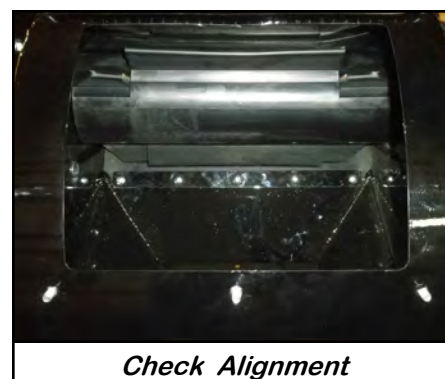
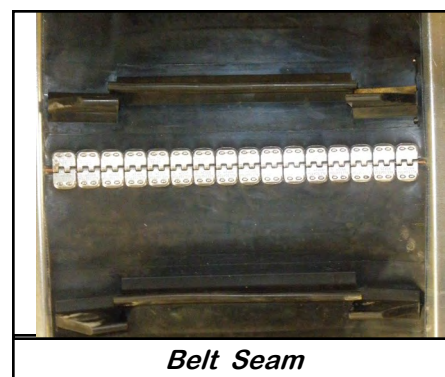

DRIVE BELT TENSION & ALIGNMENT

Power to the conveying belt is transmitted through a V-belt. The V-belt drive system must be maintained at the proper belt tension and pulley alignment to obtain the desired performance and life. When maintaining the belt drive system for the electric drive model, follow this procedure:

NOTICE

Turn motor off and unplug power cord or turn off power and lock out the master panel before starting maintenance on drive belt system.

AVIS

Arrêter le moteur et débranchez le cordon d'alimentation ou coupez l'alimentation et verrouiller le panneau de maître avant de commencer la maintenance sur le système de courroie d'entraînement.

Drive Belt Tension

1. Push on the center of the belt span with a force of approximately 5 to 10 lbs.
2. Follow the belt tensioning specification on page 43 to determine proper belt deflection.
3. Move the motor up, using the adjustment bolts, to set drive belt tension (top, right).
4. Close and secure guards.



Motor base adjustment

Drive Belt Alignment

1. Lay a straightedge across the pulley faces to check the alignment (bottom, right).
2. Use the pulley hub or the motor mounting plate slots to move the pulley to the required position for alignment.
3. Tighten hub bolts to secure pulley on shaft.
4. Check belt tension
5. Close and secure guards.



Lay a straightedge across pulley faces

Drive Belt Replacement

1. Lower motor to its loosest position.
2. Remove old belt and replace with a new one.
3. Raise motor to set the belt tension.
4. Check pulley alignment. Adjust if required.
5. Close and secure guards.

BELT TENSIONING SPECIFICATION**SECTION
G**

V-Belt tensioning adjustment can be made using a tension meter or other type spring scale using the following procedure. After seating the belts in the groove and adjusting center distance so as to take up the slack in the belts, further increase the tension until only a slight bow on the slack side is apparent while the drive is operating under load. Stop the drive and using the meter, measure the force necessary to depress one of the center belts 1/64 inch for every inch of belt span (see sketch below). For example, a deflection for a 50 inch belt span is 50/64 or 25/32 inch. The amount of force required to deflect the belt should compare with the deflection forces noted in the table below. Also notice for V- Belts that deflection forces vary from the initial RUN - IN values which are greater (reflecting higher run-in tensioning) to the NORMAL values for after the run-in period.

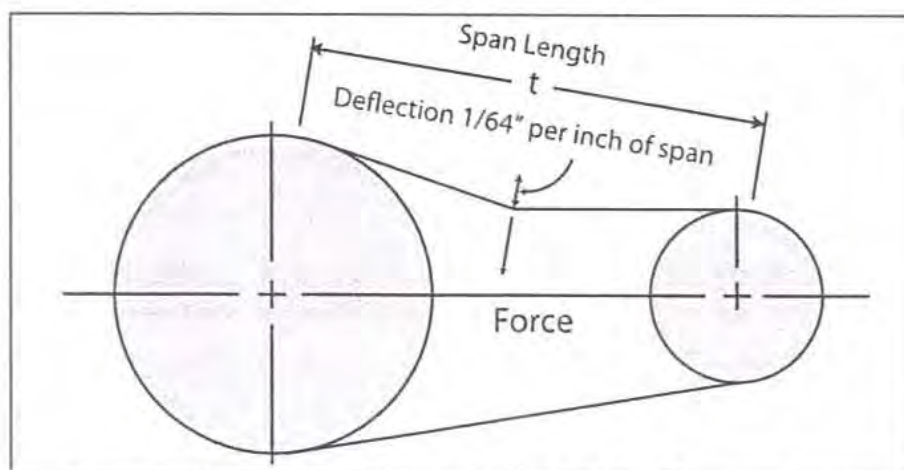

MEASURE THE SPAN LENGTH "T"
AS SHOWN IN THE SKETCH ABOVE.

BELT CROSS SECTION	SMALLER PULLEY DIAMETER RANGE (inches)	DEFLECTION FORCE	
		RUN - IN (lbs)	NORMAL (lbs)
AX	3.0 - 3.6	4 - 1/8	2 - 3/4
	3.8 - 4.8	5	3 - 1/4
	5.0 - 7.0	6	4
BX	3.4 - 4.2	5 - 1/4	3 - 1/2
	4.4 - 5.2	7 - 1/8	4 - 3/4
	5.4 - 9.4	9	6

SECTION
H**STORAGE**

When storing the Seed Series Conveyors for long periods of time, the following procedure must be followed to reduce the chance of rust, corrosion and fatigue of the conveyor. You can also use these steps when storing the machine for the winter.



A dust mask and protective rubber gloves shall be used when cleaning the machine.

1. Clear the area of bystanders, especially small children.
2. Thoroughly wash the entire machine to remove all dirt, mud, debris or residue.
3. Inspect all moving or rotating parts to see if anything has become entangled in them. Remove the entangled material.
4. Lubricate all grease fittings. Make sure that all grease cavities have been filled with grease to remove any water residue from the washing. This also protects the bearing seals.
5. Remove drive assembly cover. Clean entire area and ensure drive belt and chain are clean and free of debris. Lubricate drive chain.
6. Touch up all paint nicks and scratches to prevent rusting.
7. Move to storage area.
8. Select an area that is dry, level and free of debris.
9. Unhook from towing vehicle.
10. Place blocks under the intake or the jack if required.
11. If the machine cannot be placed inside, cover the electric motor with a water proof tarpaulin and tie securely in place.
12. Store machine in an area away from human activity.
13. Do not allow children to play on or around the stored machine.

MECHANICAL DRAWINGS

SECTION I

MANUAL TUBE ASSEMBLY (13-05-0332)

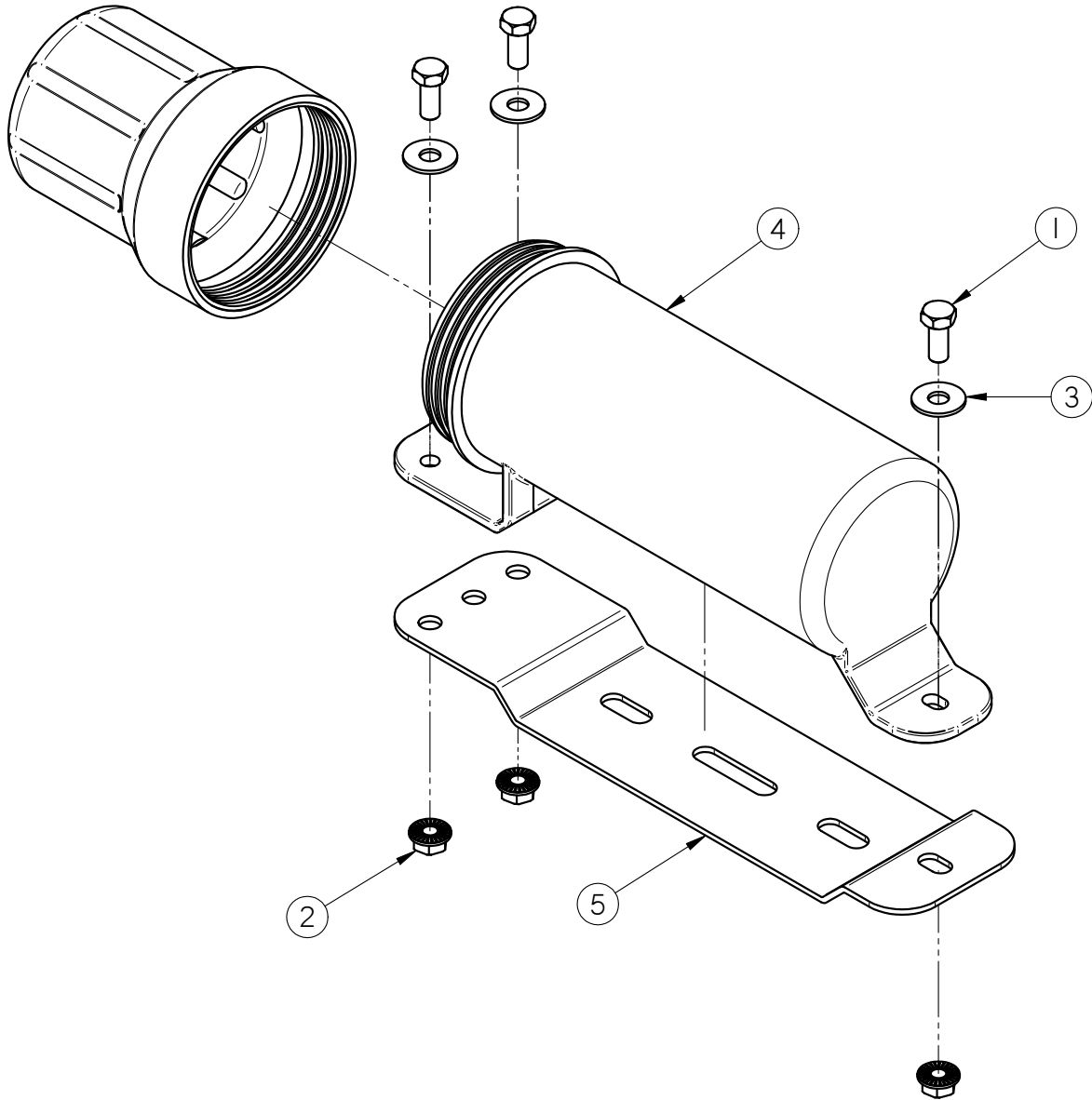

Item #	Part #	Description	Qty
1	06-01-0010	BOLT .313-18 X 0.75 ZP GR5	3
2	06-03-0019	NUT, FLG .3125-18 UNC ZP GRADE 5	3
3	06-05-0011	WASHER, .3125 FLAT 18-8 SS	3
4	08-07-0050	HOLDER MANUAL 3.25 DIA	1
5	103980	PLT MANUAL MT	1

SEED SERIES CONVEYOR 5 HP MOTOR KIT (13-05-0210)

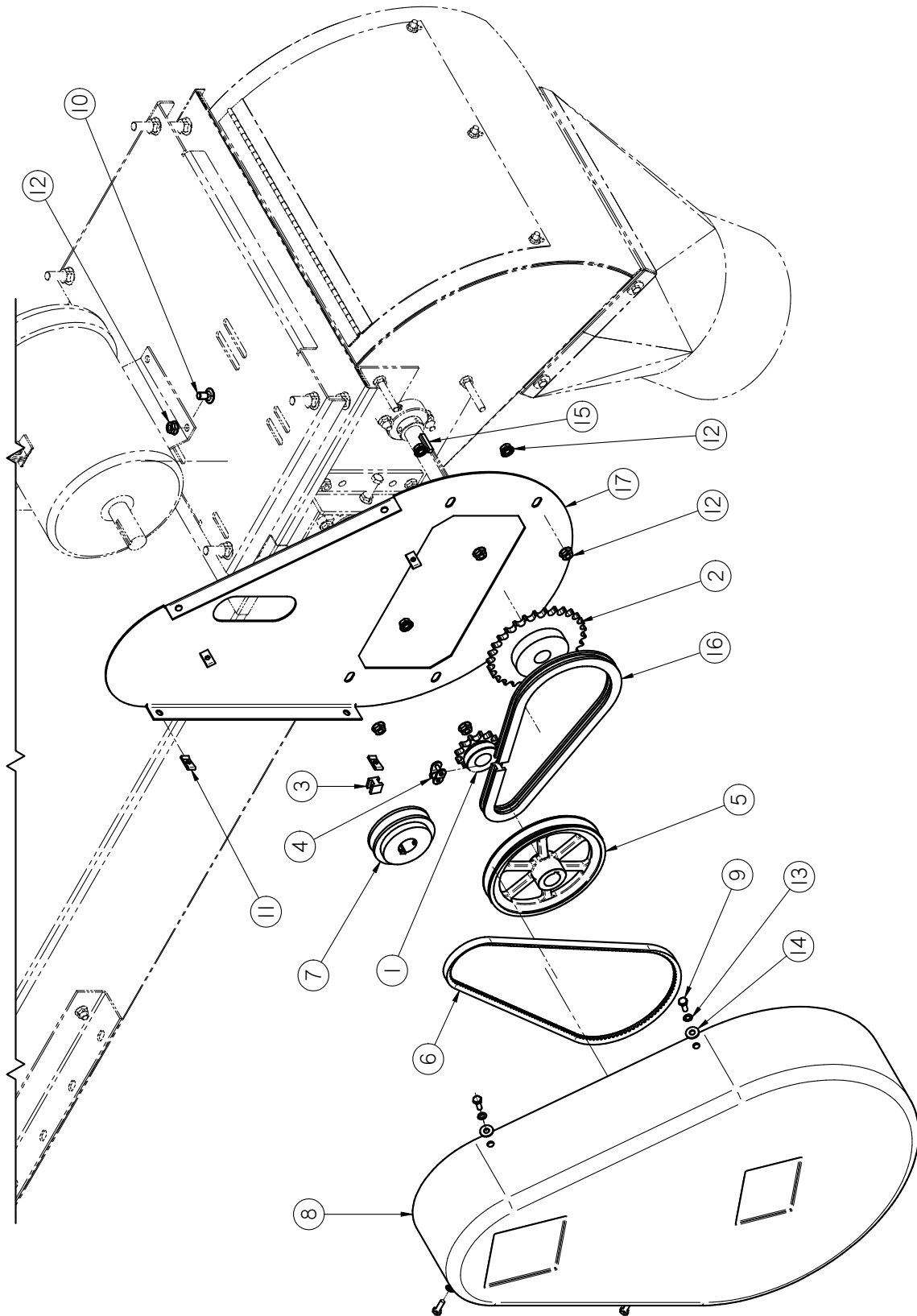

SEED SERIES 16 CONVEYOR

SEED SERIES CONVEYOR 5 HP MOTOR KIT (13-05-0210)

Item #	Part #	Description	Qty
1	01-02-0076	Sprocket #50 12T 1.0000 in Bore Type B	1
2	01-02-0109	Sprocket #50 29T 1.00 in Bore Type B	1
3	01-04-0005	#50 CNTG LINK	1
4	01-04-0007	#50 OFFSET LINK	1
5	01-08-0058	SHEAVE BK75 1.00 BORE	1
6	01-08-0059	BELT BX38	1
7	01-08-0063	SHV BK36 1.125 FSH BORE	1
8	05-06-0035	DRIVE SHIELD MOLDED	1
9	06-01-0006	BOLT .250-20 X .750 ZP GR5	4
10	06-01-0153	BOLT CRG .375-16X.750 ZP SHORT NECK	4
11	06-02-0047	NUT .250-20 U-CLIP NUT	4
12	06-03-0014	NUT LOCK FLG .375-16 ZP GR5	12
13	06-04-0001	WSHR LOCK SPLT .250 ZP	4
14	06-05-0001	WASHER, FLAT .250	4
15	106-3-2036	KEY .250 X 1.25 CS	3
16	13-05-0185	50 ROLLER CHAIN 28.5IN	1
17	280-3-0053	SHIELD BACKPLATE	1

SEED SERIES 16 CONVEYOR UNDERCARRIAGE 20 - 35 FT

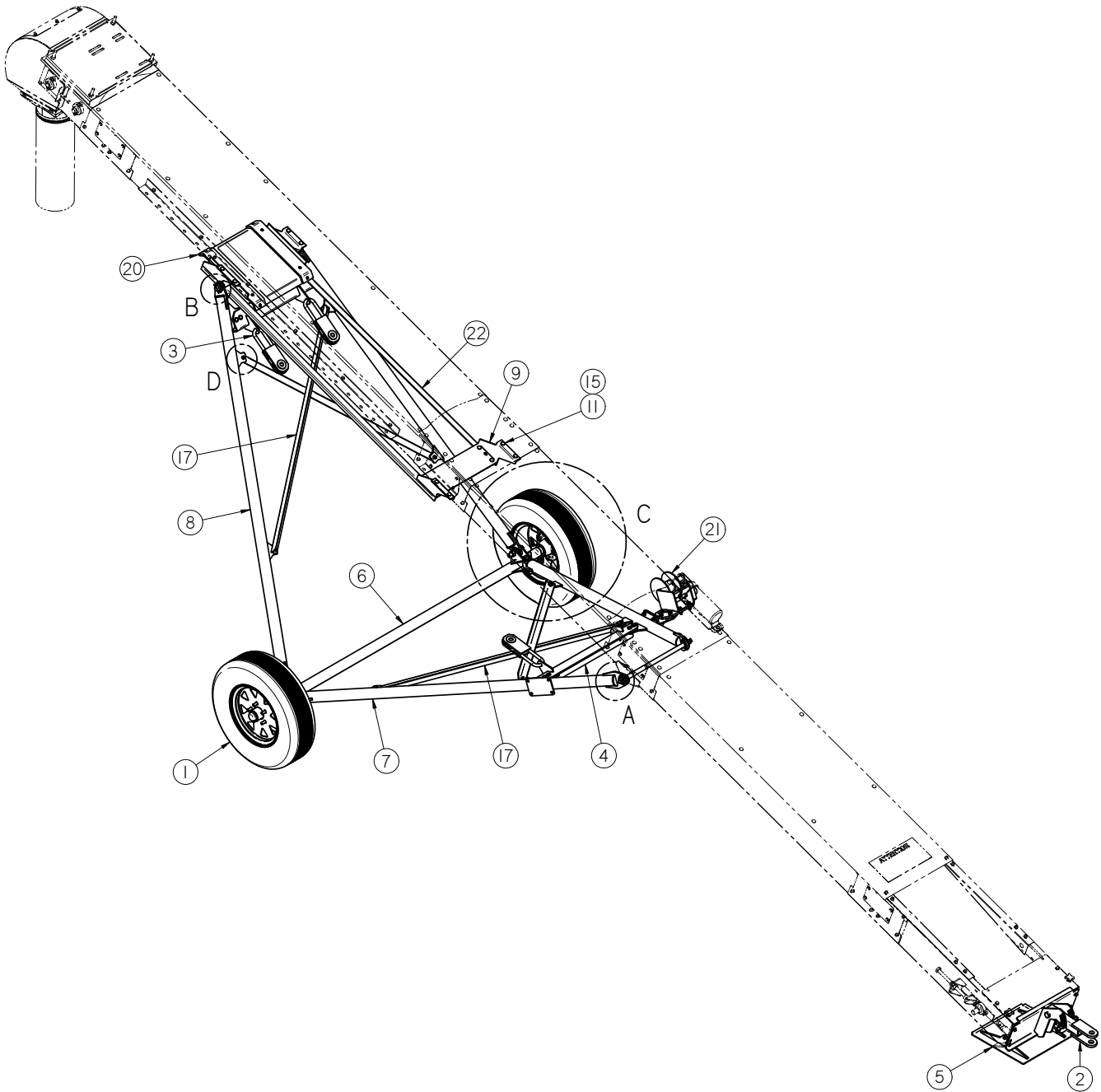

SEED SERIES 16 CONVEYOR UNDERCARRIAGE 20 - 35 FT

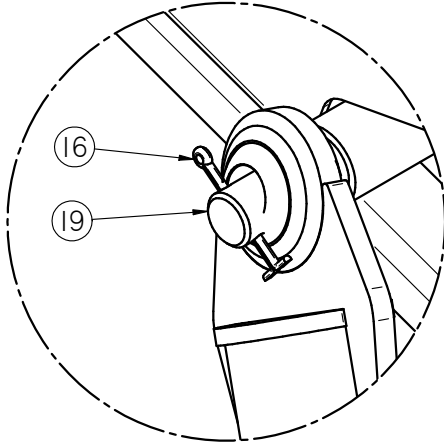

DETAIL B

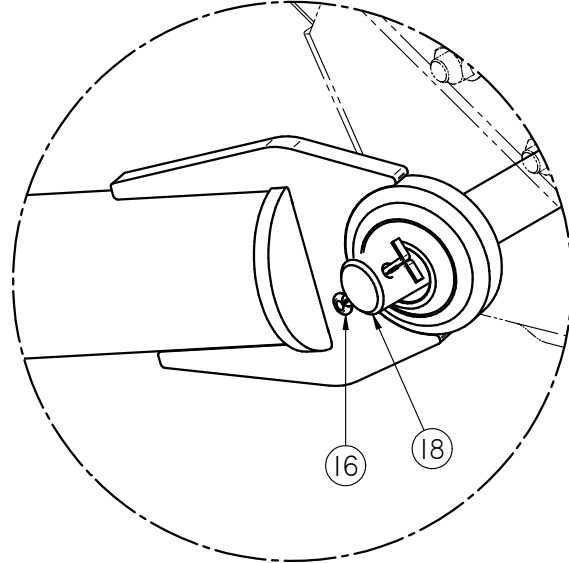

DETAIL A

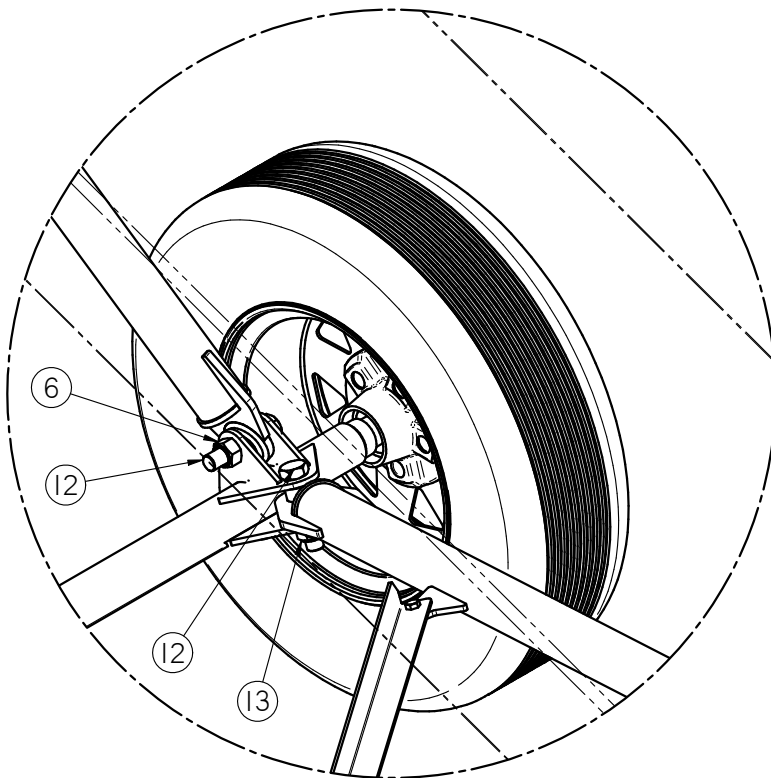

DETAIL C

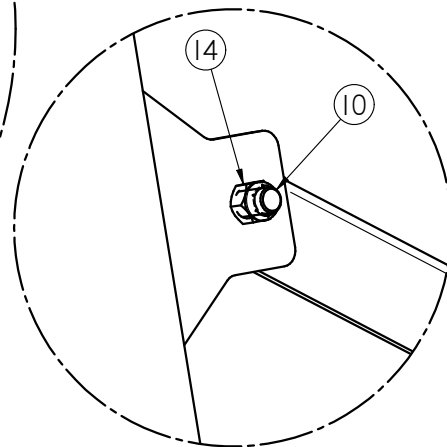

DETAIL D

SEED SERIES 16 CONVEYOR

SEED SERIES 16 CONVEYOR UNDERCARRIAGE 25 - 30 FT

SEED SERIES 16 UNDERCARRIAGE		2516		3016	
		05-08-0340		05-08-0341	
Item #	Description	Part #	Qty	Part #	Qty
1	ASSY WHL/TIRE 5BLT-15.0 X 6.0 6PLY	01-06-0150	2	01-06-0150	2
2	ASSY SS16 TAIL SECT HITCH	05-07-0641	1	05-07-0641	1
3	ASSY UPPER X MEMBER SS16 UNCG	05-07-0654	1	05-07-0654	1
4	ASSY LOWER X MEMBER SS16 UNCG	05-07-0655	1	05-07-0655	1
5	WDMT, PAD CNVR BL	05-08-0218	1	05-08-0218	1
6	ASSY AXLE SECT UNCG	05-08-0322	1	05-08-0322	1
7	WDMT LOWER ARM SS CNVR UNCG	05-08-0351	2	05-08-0363	2
8	WDMT UPPER ARM SS16 UNCG	05-08-0352	2	05-08-0365	2
9	TRANSPORT SLIDE STOP	05-10-2185	2	05-10-2185	2
10	BOLT .375-16 X 1.00 ZP GR5	06-01-0016	8	06-01-0016	8
11	BOLT CRG .375-16X.750 ZP SHORT NECK	06-01-0153	16	06-01-0153	16
12	BOLT .750-10 X 3.50 ZP GR8	06-01-0218	4	06-01-0218	4
13	NUT,LOCK, .750-10 ZP NE NYLON INSERT	06-02-0029	4	06-02-0029	4
14	NUT NYL LOCK .375-16 ZP GR5	06-03-0003	8	06-03-0003	8
15	NUT LOCK FLG .375-16 ZP GR5	06-03-0014	16	06-03-0014	16
16	.188 X 2.00 ZP COTTER PIN	06-09-0023	4	06-09-0023	4
17	PLT X BRACE UNCG	102FBC	4	102FBC	4
18	LOWER ARM PIN SS16 UNCG	102FE5	1	102FE5	1
19	UPPER ARM PIN SS16 UNCG	102FE6	1	102FE6	1
20	ASSY TRANSPORT SLIDE 16BW PORT	13-05-0232	1	13-05-0232	1
21	ASSY WINCH KIT SS CNVR	13-05-0300	1	13-05-0300	1
22	TRANSPORT SLIDE TRAP	280-3-0089	2	280-3-0089	2

SEED SERIES 16 CONVEYOR HEAD SECTION (13-08-0617)

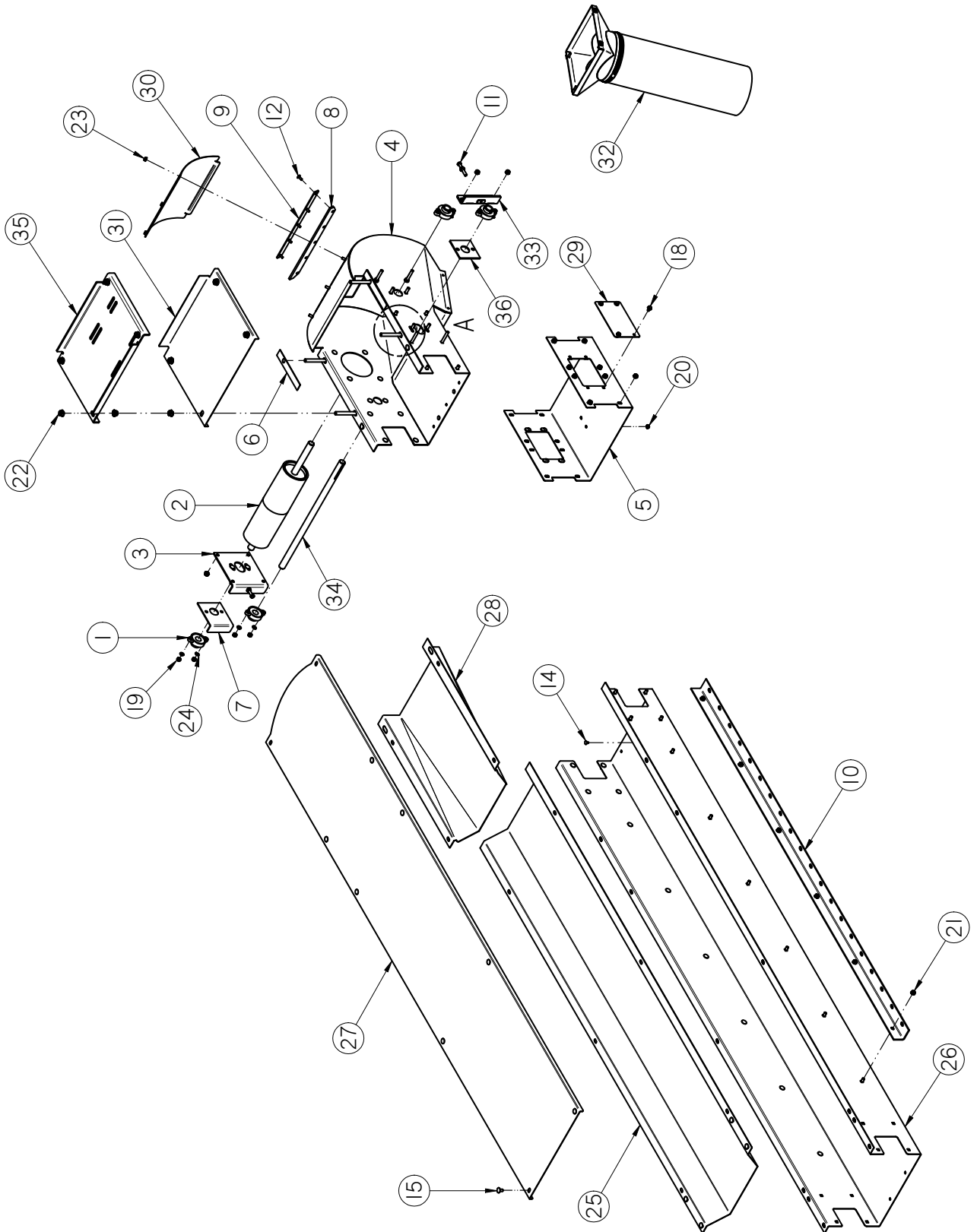

SEED SERIES 16 CONVEYOR

SEED SERIES 16 CONVEYOR HEAD SECTION (13-08-0617)

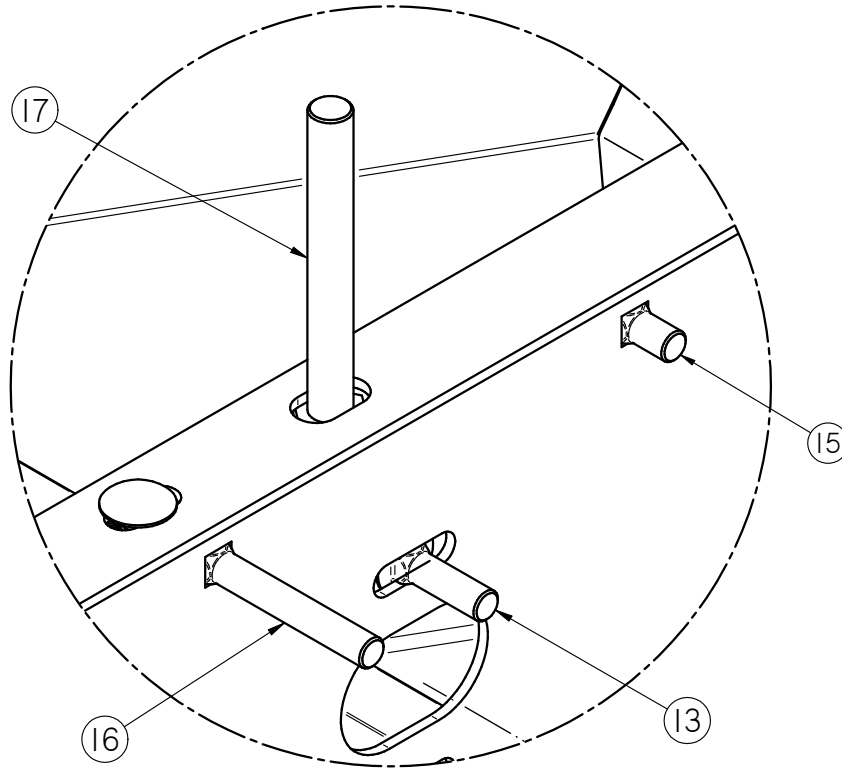

DETAIL A

Item #	Part #	Description	Qty
1	01-03-0042	BRG FLG MNT 1.000ID 2BOLT ECNTRC	4
2	01-08-0096	PULLEY HEAD VULC S2000	1
3	05-07-0445	WDMT ADJ PLT CNVR HEAD SECT	1
4	05-08-0411	WDMT DSCGH HD 16IN	1
5	05-08-0412	WDMT SPLICE 16IN	1
6	05-10-3267	SPCR UB HEAD CVR 16GA	2
7	05-10-3947	PLT BRG ADJ STRIKE	1
8	05-10-3985	PLT S2000 CNVR BLT SCRAPER RBBR	1
9	05-10-3986	PLT S2000 CNVR BLT SCRAPER HLDR	1
10	05-10-4028	TRANSPORT STOP PLT EXT MNT	2
11	06-01-0071	BOLT .375-16 X 2.50 ZP GR5	2
12	06-01-0122	BOLT, CARRIAGE, .250-20x.75 G5 ZP	5
13	06-01-0127	BOLT CRG .375-16 X 1.25 ZP GR5	8
14	06-01-0150	BOLT, CARRIAGE, .250-20x.50 G5 ZP	4
15	06-01-0153	BOLT CRG .375-16X.750 ZP SHORT NECK	46

SEED SERIES 16 CONVEYOR

SEED SERIES 16 CONVEYOR HEAD SECTION (13-08-0617)

Item #	Part #	Description	Qty
16	06-01-0154	BOLT CRG .375-16 X 2.50 FTH ZP GR5	4
17	06-01-0157	BOLT, .500-13 X 4" UNC ZP GRADE 5 fth	4
18	06-01-0261	BOLT FLG .3125-18 X .500 ZP GR5	8
19	06-02-0003	NUT FULL .375-16 ZP GR5	8
20	06-03-0013	NUT,LOCK, FLG .250-20 ZP SERRATTED	9
21	06-03-0014	NUT LOCK FLG .375-16 ZP GR5	52
22	06-03-0015	NUT LOCK FLG .500-13 ZP GR5	12
23	06-03-0019	NUT LOCK FLG .3125-18 ZP GR5	3
24	06-04-0003	WSHR LOCK SPLT .375 ZP	8
25	102F69	TROUGH PAN 16BW HEAD SECT	1
26	102F6A	FR 16BW HEAD SECT 10FT SPLICED	1
27	102F6B	TOP COVER 10FT MID SECTION	1
28	102F85	TRAN HEAD SECT S2000	1
29	103B9A	PLT SPLICE COVER	2
30	103BC6	PLT INSP CVR 16IN DSCHG	1
31	104462	TOP COVER DISCHARGE	1
32	13-05-0227	ASSY 8ID FLEX SPOUT S2000	1
33	280-2-0016	TRACKING ANGLE WELDMENT	1
34	280-3-0048	24 X 1 INCH JACK-HEAD SHAFT	1
35	280-3-0052	MTR MNT	1
36	280-3-0112	BEARING SPACER PLATE	1

SEED SERIES 16 CONVEYOR

5 FT MID SECTION (13-08-0615)

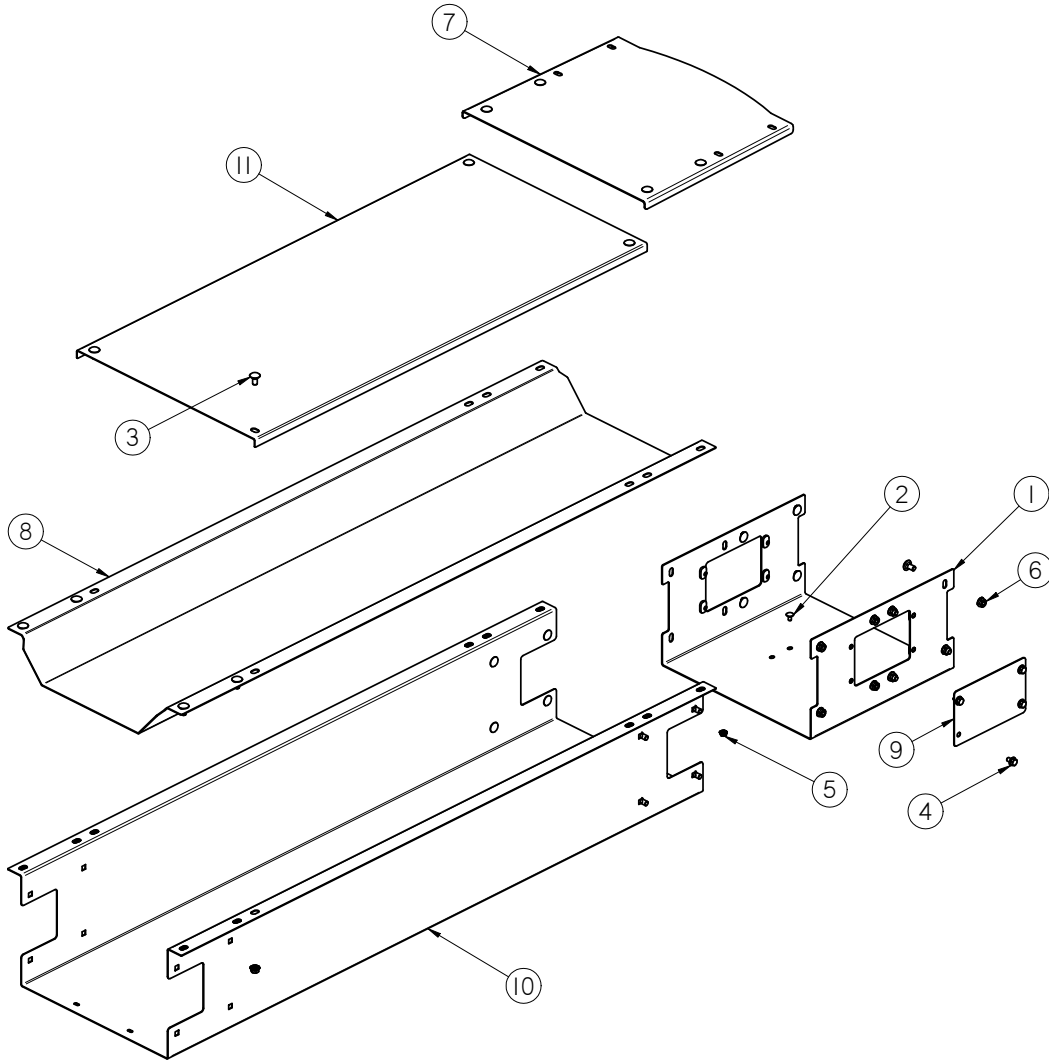

Item #	Part #	Description	Qty
1	05-08-0412	WDMT SPLICE 16IN	1
2	06-01-0150	BOLT, CARRIAGE, .250-20x.50 G5 ZP	4
3	06-01-0153	BOLT CRG .375-16X.750 ZP SHORT NECK	28
4	06-01-0261	BOLT FLG .3125-18 X .500 ZP GR5	8
5	06-03-0013	NUT,LOCK, FLG .250-20 ZP SERRATTED	4
6	06-03-0014	NUT LOCK FLG .375-16 ZP GR5	28
7	10286F	SPLICE COVER S2000	1
8	1030EB	TROUGHING PAN 5 FT MID SECTION	1
9	103B9A	PLT SPLICE COVER	2
10	280-3-0092	FRAME-5FT MID SECTION	1
11	280-3-0093	TOP COVER 5FT MID SECTION	1

SEED SERIES 16 CONVEYOR

INLET EXTENSION (13-08-0614)

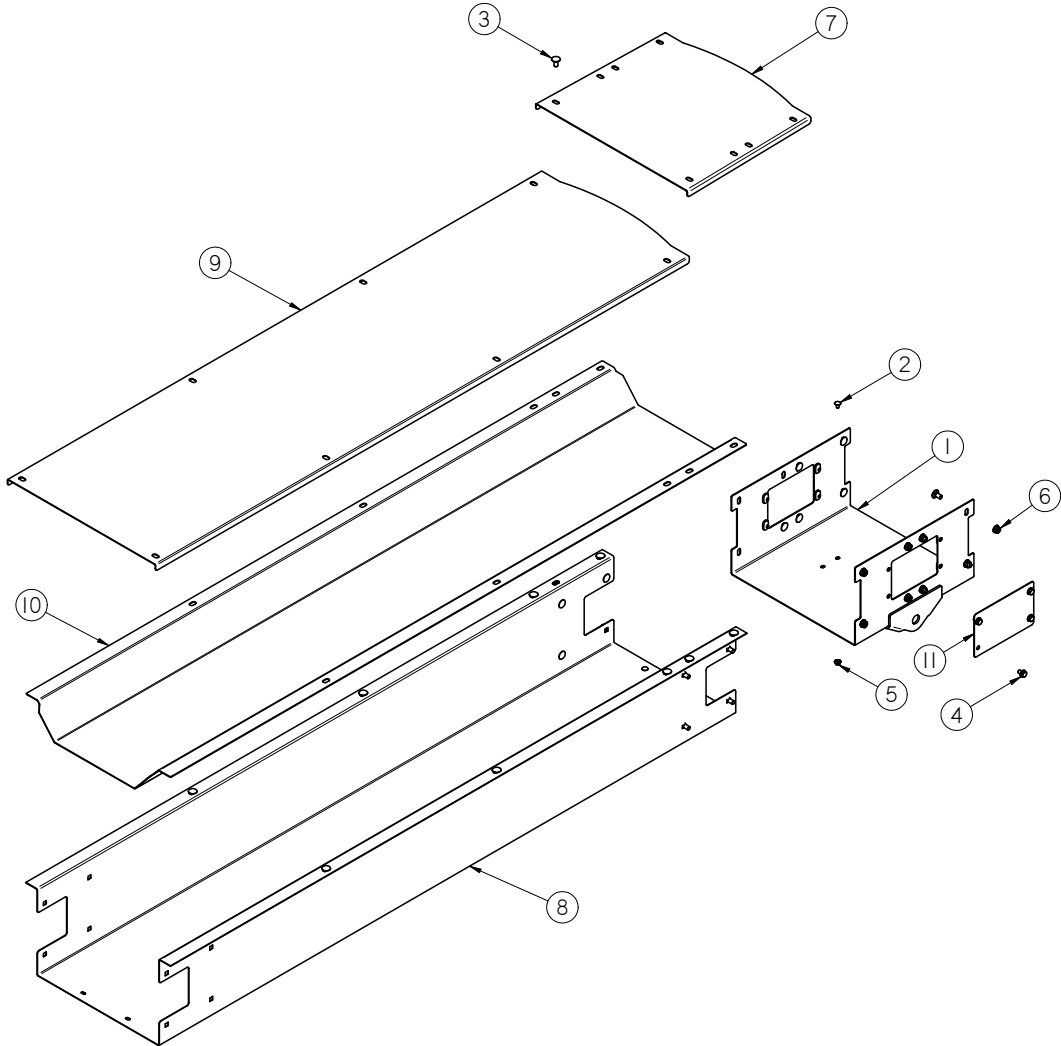

Item #	Part #	Description	Qty
1	05-08-0423	WDMT SPLICE TRANS MT 16IN	1
2	06-01-0150	BOLT, CARRIAGE, .250-20x.50 G5 ZP	4
3	06-01-0153	BOLT CRG .375-16X.750 ZP SHORT NECK	26
4	06-01-0261	BOLT FLG .3125-18 X .500 ZP GR5	8
5	06-03-0013	NUT,LOCK, FLG .250-20 ZP SERRATTED	4
6	06-03-0014	NUT LOCK FLG .375-16 ZP GR5	26
7	10286F	SPLICE COVER S2000	1
8	1029D0	FR 16BW TAIL SECT	1
9	1029D2	TOP COVER INLET SEC S2000	1
10	1030ED	TROUGH PAN 16BW TAIL SECT	1
11	103B9A	PLT SPLICE COVER	2

10FT MID SECTION (13-08-0616)

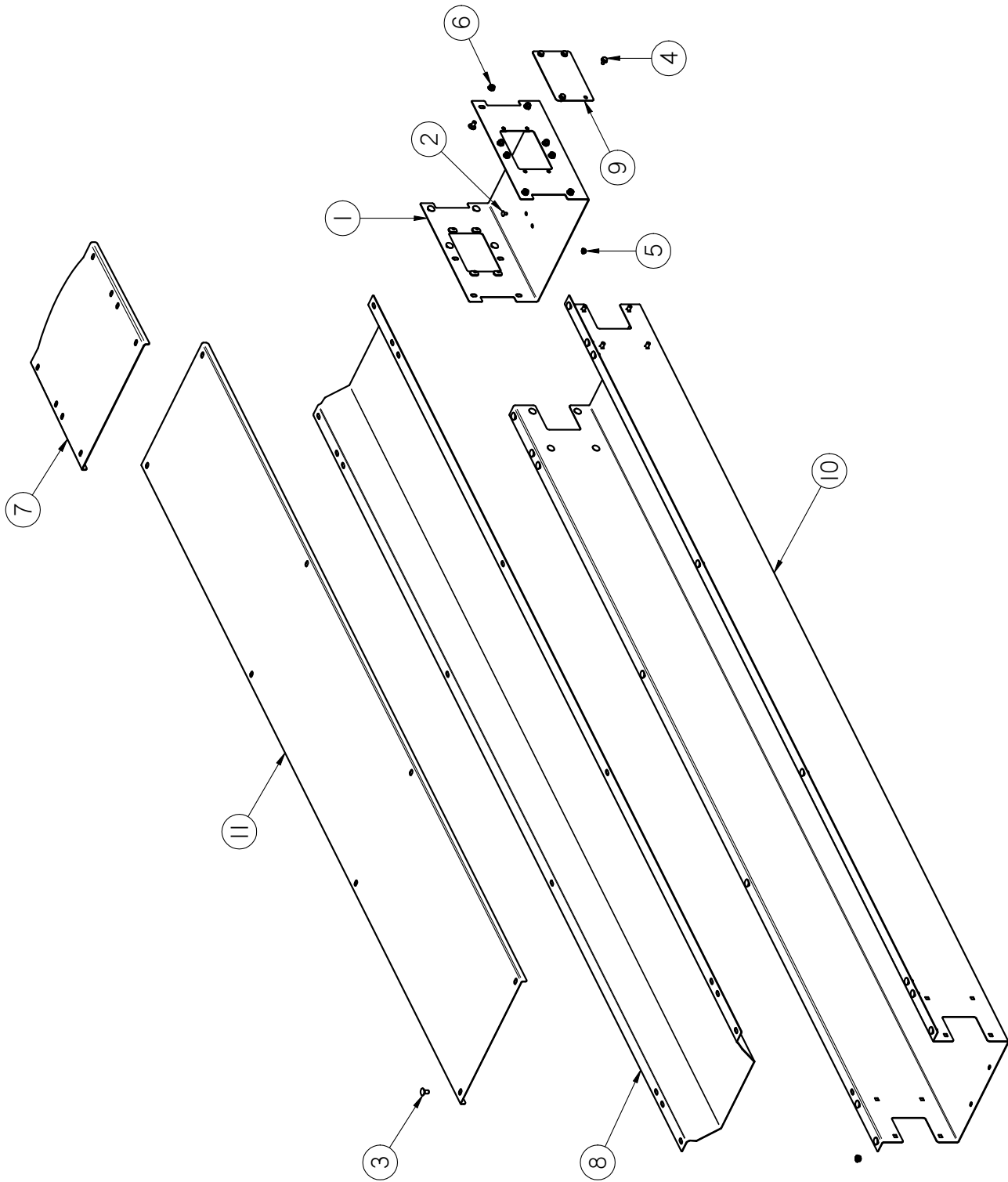

SEED SERIES 16 CONVEYOR

10FT MID SECTION (13-08-0616)

Item #	Part #	Description	Qty
1	05-08-0412	WDMT SPLICE 16IN	1
2	06-01-0150	BOLT, CARRIAGE, .250-20x.50 G5 ZP	4
3	06-01-0153	BOLT CRG .375-16X.750 ZP SHORT NECK	32
4	06-01-0261	BOLT FLG .3125-18 X .500 ZP GR5	8
5	06-03-0013	NUT,LOCK, FLG .250-20 ZP SERRATTED	4
6	06-03-0014	NUT LOCK FLG .375-16 ZP GR5	32
7	10286F	SPLICE COVER S2000	1
8	1030EC	TROUGHING PAN-10FT MID SECTION	1
9	103B9A	PLT SPLICE COVER	2
10	280-3-0001	FRAME-10FT MID SECTION	1
11	280-3-0002	TOP COVER 10FT MID SECTION	1

SEED SERIES 16 CONVEYOR

INLET SECTION (13-08-0612)

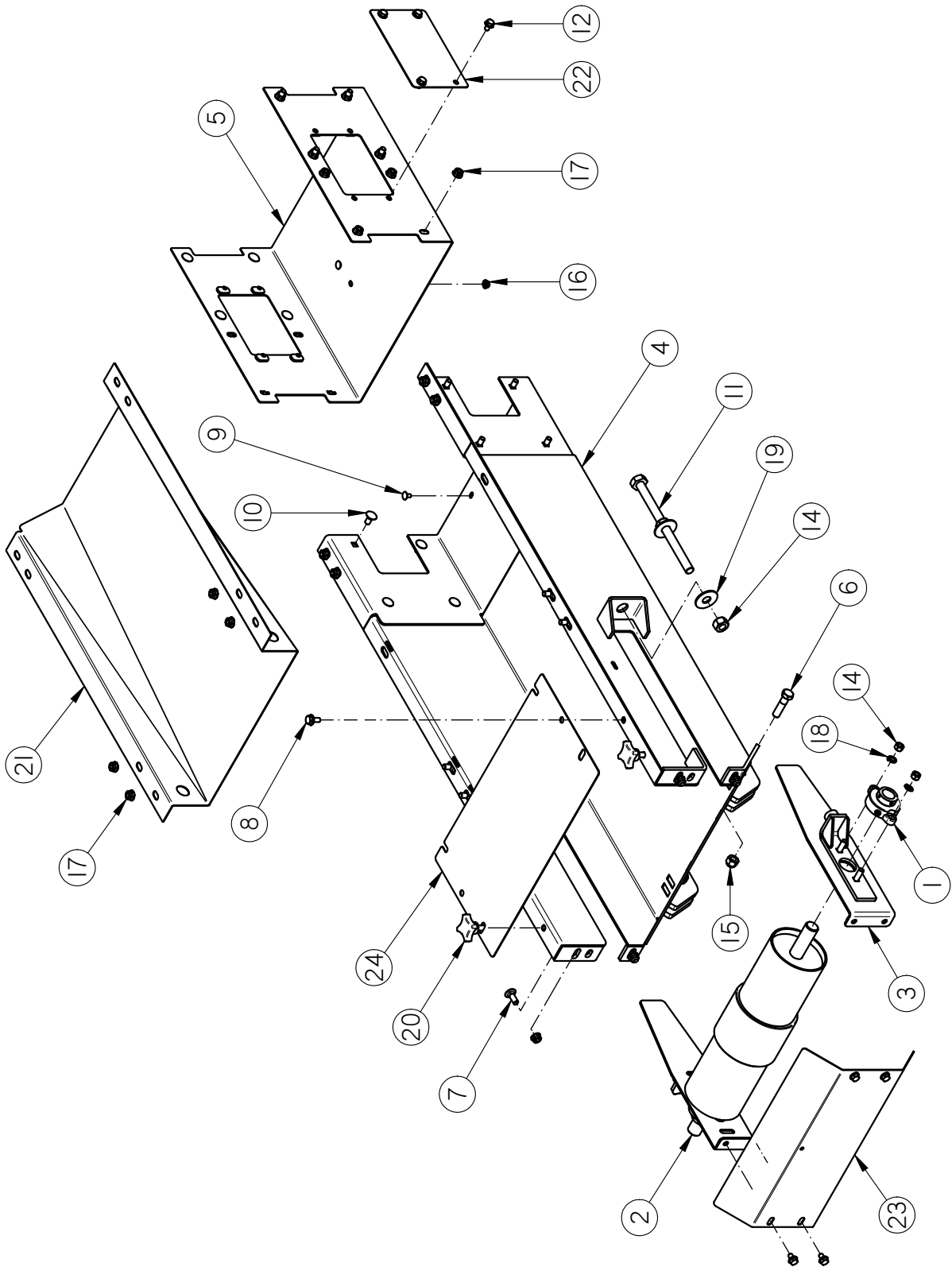

SEED SERIES 16 CONVEYOR

INLET SECTION (13-08-0612)

Item #	Part #	Description	Qty
1	01-03-0042	BRG FLG MNT 1.000ID 2BOLT ECNTRC	2
2	01-08-0095	PULLEY TAIL W-LAGGING	1
3	05-08-0404	WDMT TAKE-UP PLT RND CNVR	2
4	05-08-0408	WDMT INLET HSG 16IN RND	1
5	05-08-0412	WDMT SPLICE 16IN	1
6	06-01-0027	BOLT .500-13 X 2.00 ZP GR5	2
7	06-01-0115	BOLT CRG .375-16 X 1.00 ZP GR5	4
8	06-01-0124	BOLT FLG .375-16 X .750 ZP GR5	2
9	06-01-0150	BOLT, CARRIAGE, .250-20x.50 G5 ZP	4
10	06-01-0153	BOLT CRG .375-16X.750 ZP SHORT NECK	24
11	06-01-0249	BOLT .625-11 X 9.00 ZP GR5 FTH	2
12	06-01-0261	BOLT FLG .3125-18 X .500 ZP GR5	12
13	06-02-0003	NUT FULL .375-16 ZP GR5	4
14	06-02-0005	NUT, .625-11 UNC ZP GRADE 5	4
15	06-03-0004	NUT NYL LOCK .500-13 ZP GR5	2
16	06-03-0013	NUT,LOCK, FLG .250-20 ZP SERRATTED	4
17	06-03-0014	NUT LOCK FLG .375-16 ZP GR5	30
18	06-04-0003	WSHR LOCK SPLT .375 ZP	4
19	06-05-0006	WASHER, .625 FLAT ZP	4
20	06-09-0066	KNOB .375 -16 X 1. 4 LUG PLASTIC	2
21	102F31	TROUGH TRANSITION PLATE S2000	1
22	103B9A	PLT SPLICE COVER	2
23	10426C	PLT COVER TAKE-UP 16IN	1
24	1047FA	PLT INLET CVR TOP SS16	1

SEED SERIES 16 CONVEYOR

BASE CONVEYOR - 25 FT (13-08-0621)

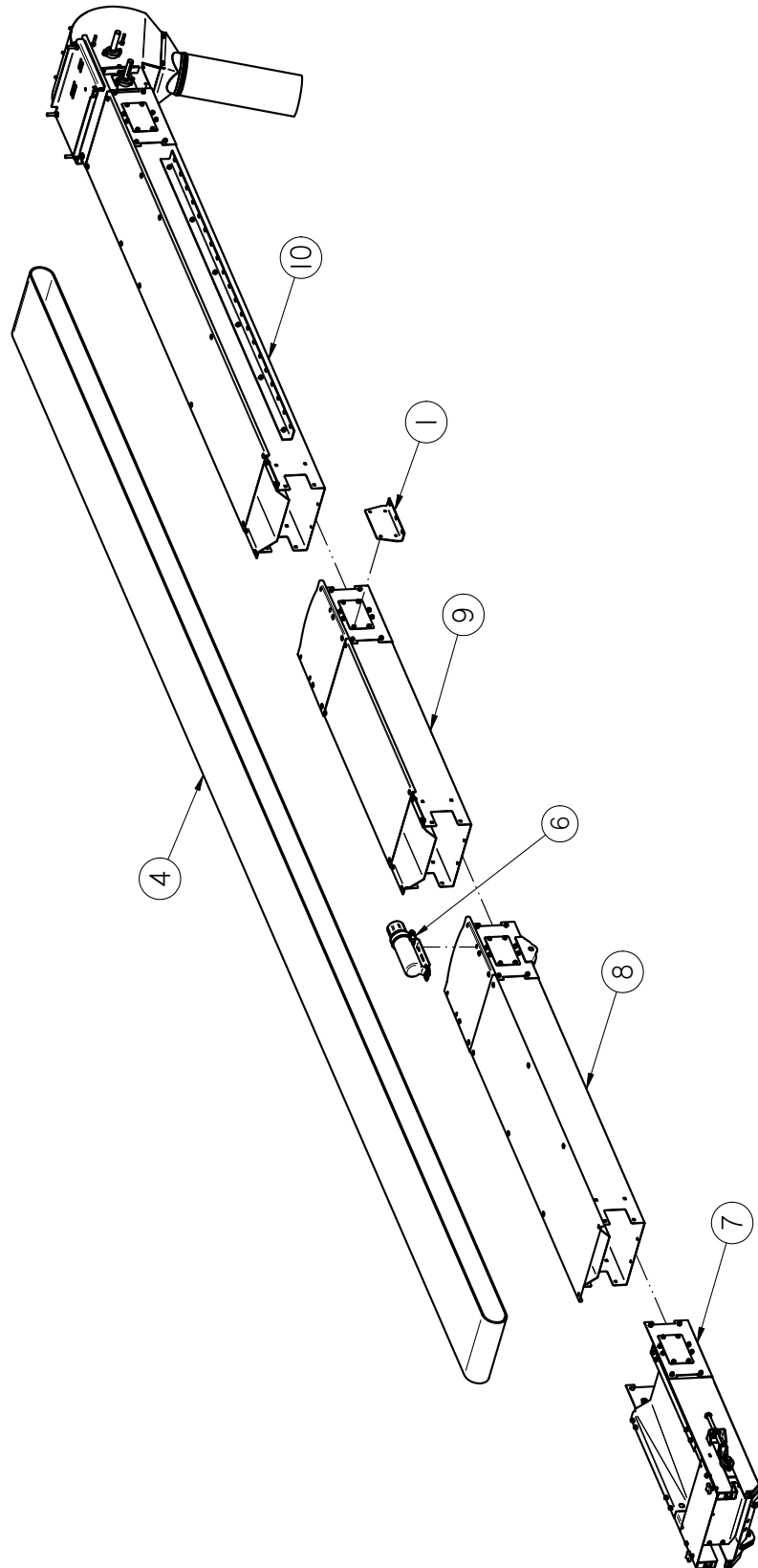

SEED SERIES 16 CONVEYOR

BASE CONVEYOR - 25 FT (13-08-0621)

Item #	Part #	Description	Qty
1	05-10-4339	PLT STOP MOUNT	2
2	09-01-0070	LBL ATWK 2516	2
3	09-02-0016	LBL ATWRK ATT BELT ALIGN	1
4	11-02-0022	BELT CNVR CLTS 2516	1
5	13-05-0315	DECAL PKG SS CNVRS	1
6	13-05-0332	ASSY MANUAL TUBE MT	1
7	13-08-0612	ASSY INLET SECT SS16	1
8	13-08-0614	ASSY INLET EXT SS16	1
9	13-08-0615	ASSY 5FT MID SECT SS16	1
10	13-08-0617	ASSY HEAD SECT SS16	1

NOTE: Items 2, 3 and 5 not shown on drawing.

SEED SERIES 16 CONVEYOR
BASE CONVEYOR - 30 FT (13-08-0622)

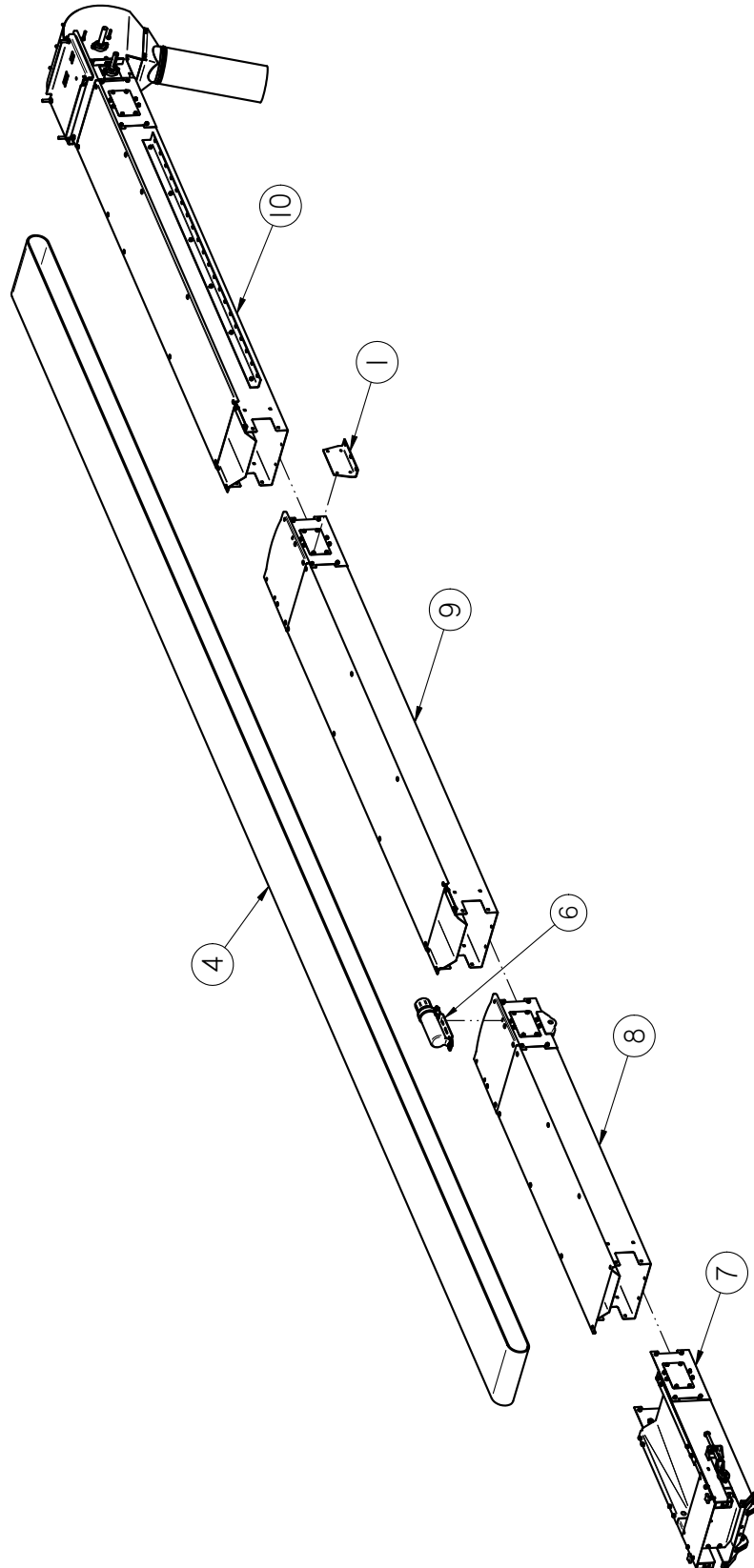

SEED SERIES 16 CONVEYOR

BASE CONVEYOR - 30 FT (13-08-0622)

Item #	Part #	Description	Qty
1	05-10-4339	PLT STOP MOUNT	2
2	09-01-0071	LBL ATWK 3016	2
3	09-02-0016	LBL ATWRK ATT BELT ALIGN	1
4	11-02-0021	BELT CNVR CLTS 3016	1
5	13-05-0315	DECAL PKG SS CNVRS	1
6	13-05-0332	ASSY MANUAL TUBE MT	1
7	13-08-0612	ASSY INLET SECT SS16	1
8	13-08-0614	ASSY INLET EXT SS16	1
9	13-08-0616	ASSY 10FT MID SECT SS16	1
10	13-08-0617	ASSY HEAD SECT SS16	1

NOTE: Items 2, 3 and 5 not shown on drawing.

SEED SERIES 16 CONVEYOR

INLET HOPPER - BLANK (13-08-0442)

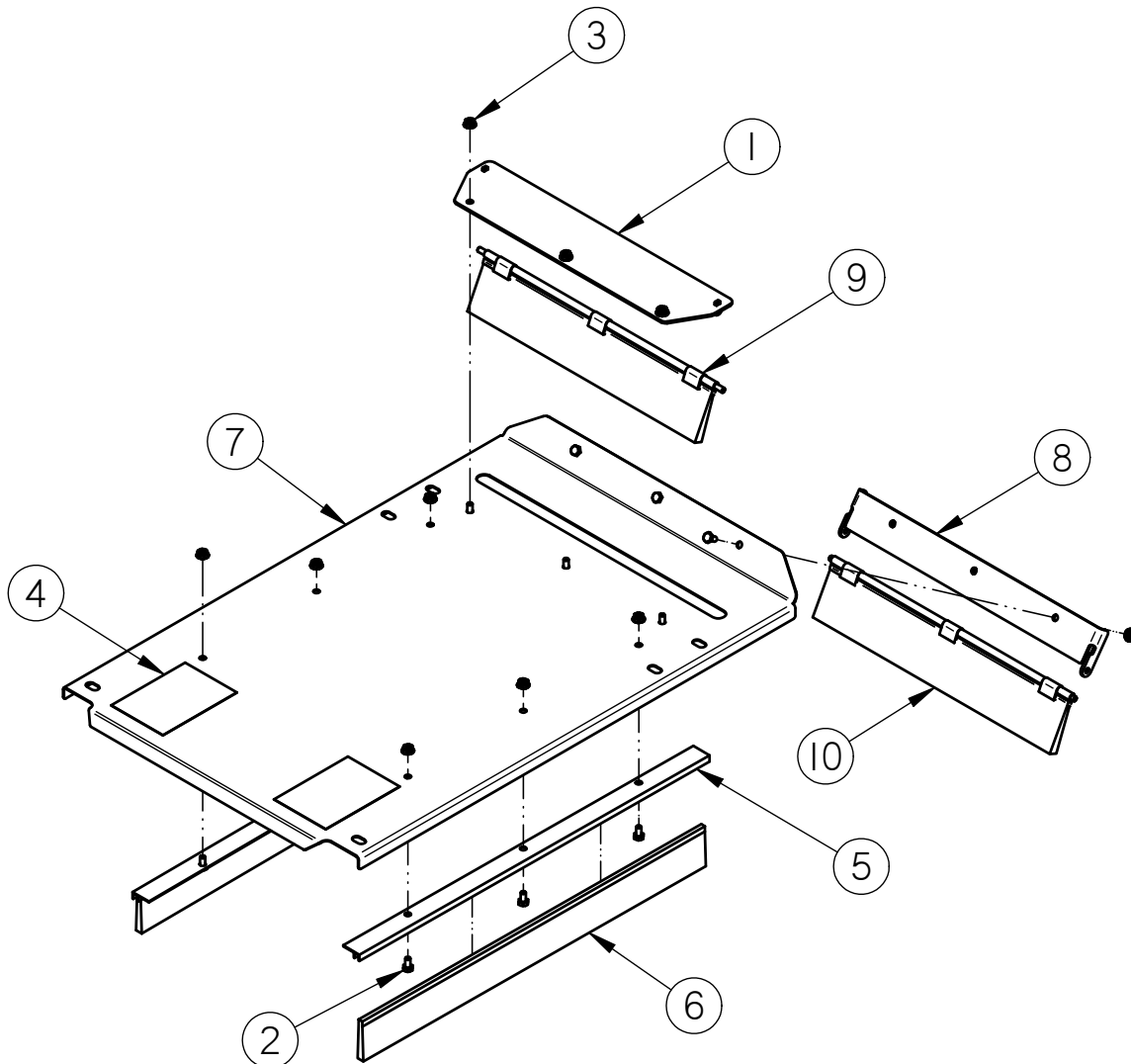

Item #	Part #	Description	Qty
1	05-08-0537	WDMT PIVOT BRSH PLT TS35	1
2	06-01-0004	BOLT, .250-20 X .500 UNC ZP GRADE 5	12
3	06-03-0013	NUT,LOCK, FLG .250-20 ZP SERRATED	12
4	09-02-0001	ATWK LBL DANGER FINGERS	2
5	10328A	INLET HOPPER BRUSH HOLDER	2
6	10328B	BRUSH	2
7	1033A2	PLT INLET BLANK SS16	1
8	104739	EAR BRUSH MNT	1
9	13-05-0480	ASSY BRUSH W\CLIPS 15.438	1
10	13-05-0481	ASSY BRUSH W\CLIPS 16.062	1

SEED SERIES 16 CONVEYOR
INLET HOPPER - RIGID (13-08-0437)

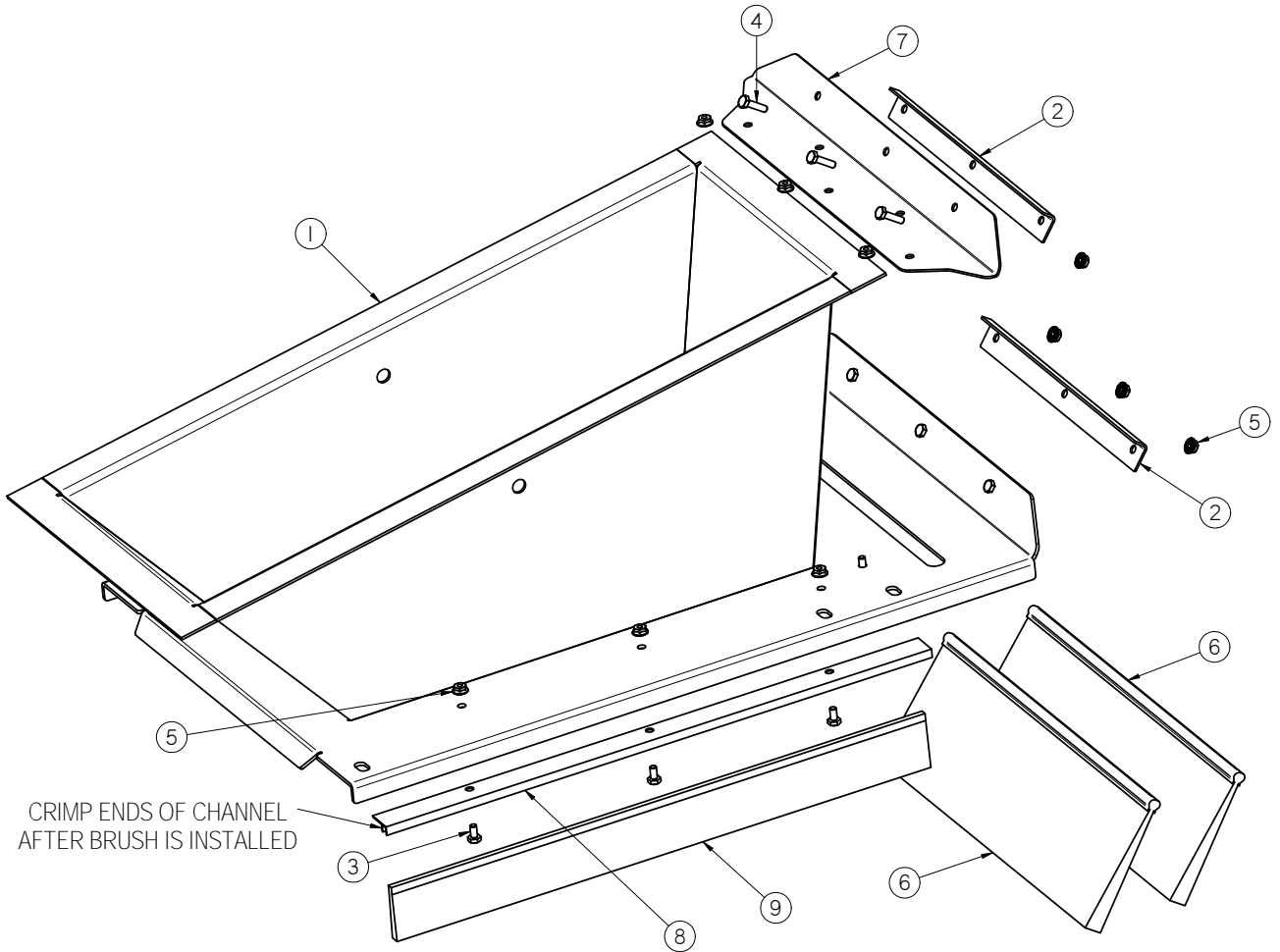

Item #	Part #	Description	Qty
1	05-07-0724	WDMT SS16 RIGID INLET HOPPER	1
2	05-10-2138	INLET BRSH HLDR S2000	2
3	06-01-0004	BOLT, .250-20 X .500 UNC ZP GRADE 5	9
4	06-01-0007	BOLT, .250-20 X 1 UNC ZP GRADE 5	6
5	06-03-0013	NUT, LOCK, FLG .250-20 ZP SERRATED	15
6	06-10-0051	BRUSH SEAL 16.5"L	2
7	103236	PLATE BRUSH MOUNT	1
8	10328A	INLET HOPPER BRUSH HOLDER	2
9	10328B	BRUSH	2

SEED SERIES 16 CONVEYOR

INLET HOPPER - RIGID (13-08-0424)

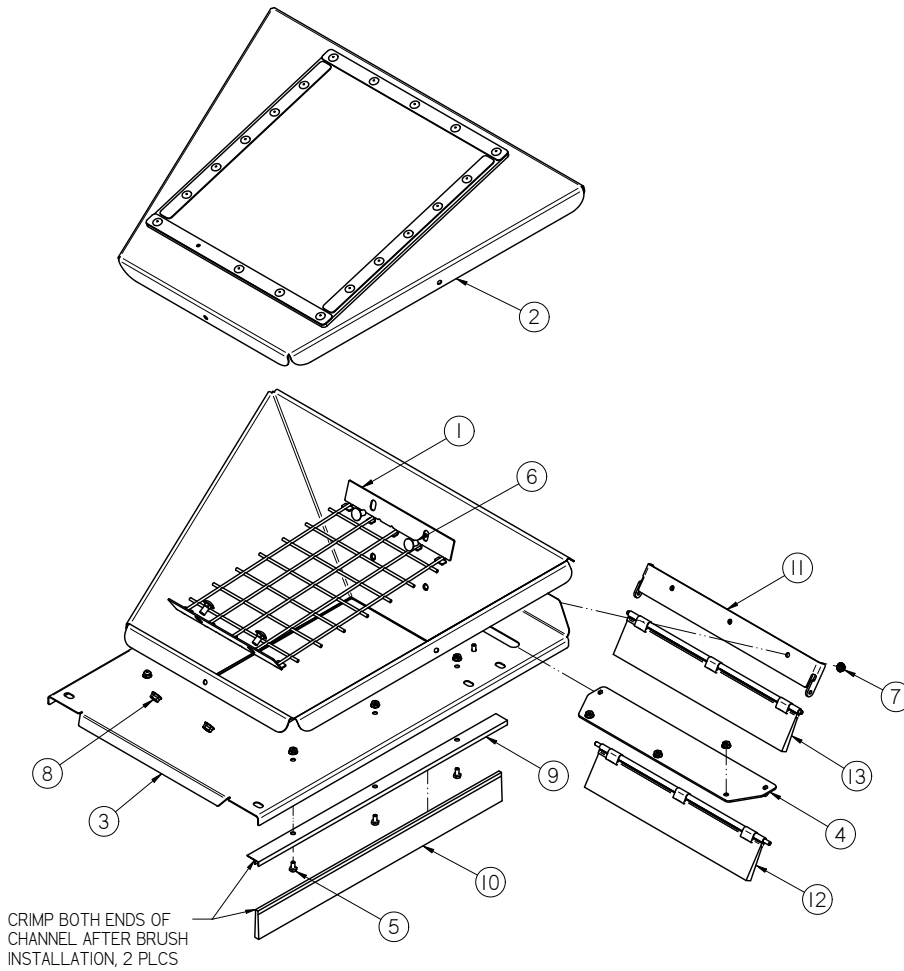

Item #	Part #	Description	Qty
1	05-06-0037	GRATE CNVR HOPP S2000	1
2	05-07-0292	ASSY CNVR INLET CVR	1
3	05-07-0708	WDMT SS16 RIGID INLET HOPPER	1
4	05-08-0537	WDMT PIVOT BRSH PLT TS35	1
5	06-01-0004	BOLT, .250-20 X .500 UNC ZP GRADE 5	12
6	06-01-0153	BOLT CRG .375-16X.750 ZP SHORT NECK	4
7	06-03-0013	NUT,LOCK, FLG .250-20 ZP SERRATTED	12
8	06-03-0014	NUT LOCK FLG .375-16 ZP GR5	4
9	10328A	INLET HOPPER BRUSH HOLDER	2
10	10328B	BRUSH	2
11	104739	EAR BRUSH MNT	1
12	13-05-0480	ASSY BRUSH W\CLIPS 15.438	1
13	13-05-0481	ASSY BRUSH W\CLIPS 16.062	1

SEED SERIES 16 CONVEYOR

INLET HOPPER - RIGID (13-08-0636)

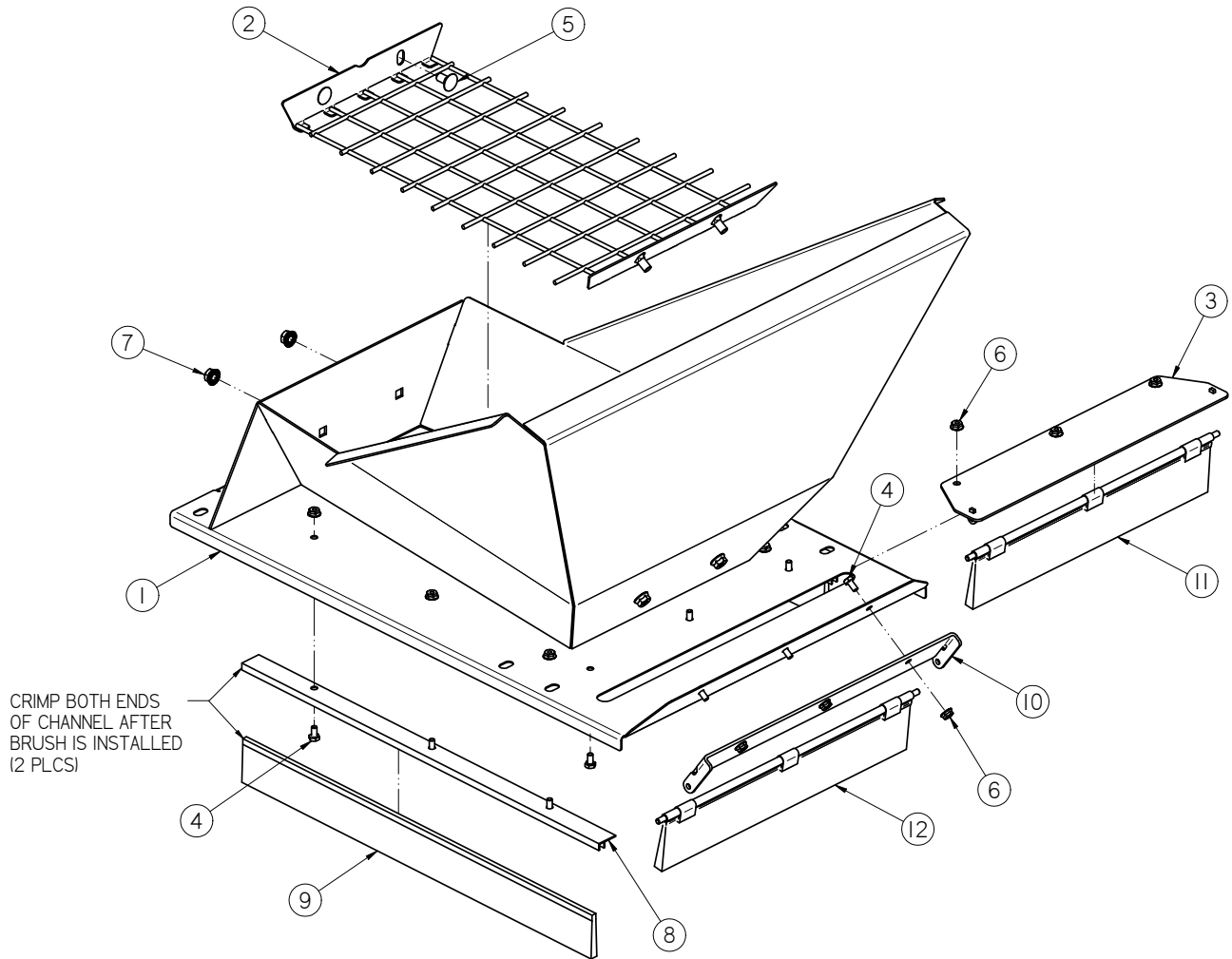

Item #	Part #	Description	Qty
1	05-08-0526	WDMT LG INLET SS16	1
2	05-08-0527	WDMT GRATE HOPP LG SS16	1
3	05-08-0537	WDMT PIVOT BRSH PLT TS35	1
4	06-01-0004	BOLT, .250-20 X .500 UNC ZP GRADE 5	12
5	06-01-0153	BOLT CRG .375-16X.750 ZP SHORT NECK	4
6	06-03-0013	NUT,LOCK, FLG .250-20 ZP SERRATTED	12
7	06-03-0014	NUT LOCK FLG .375-16 ZP GR5	4
8	10328A	INLET HOPPER BRUSH HOLDER	2
9	10328B	BRUSH	2
10	104739	EAR BRUSH MNT	1
11	13-05-0480	ASSY BRUSH W\CLIPS 15.438	1
12	13-05-0481	ASSY BRUSH W\CLIPS 16.062	1

INLET HOPPER - ROUND (13-08-0421)

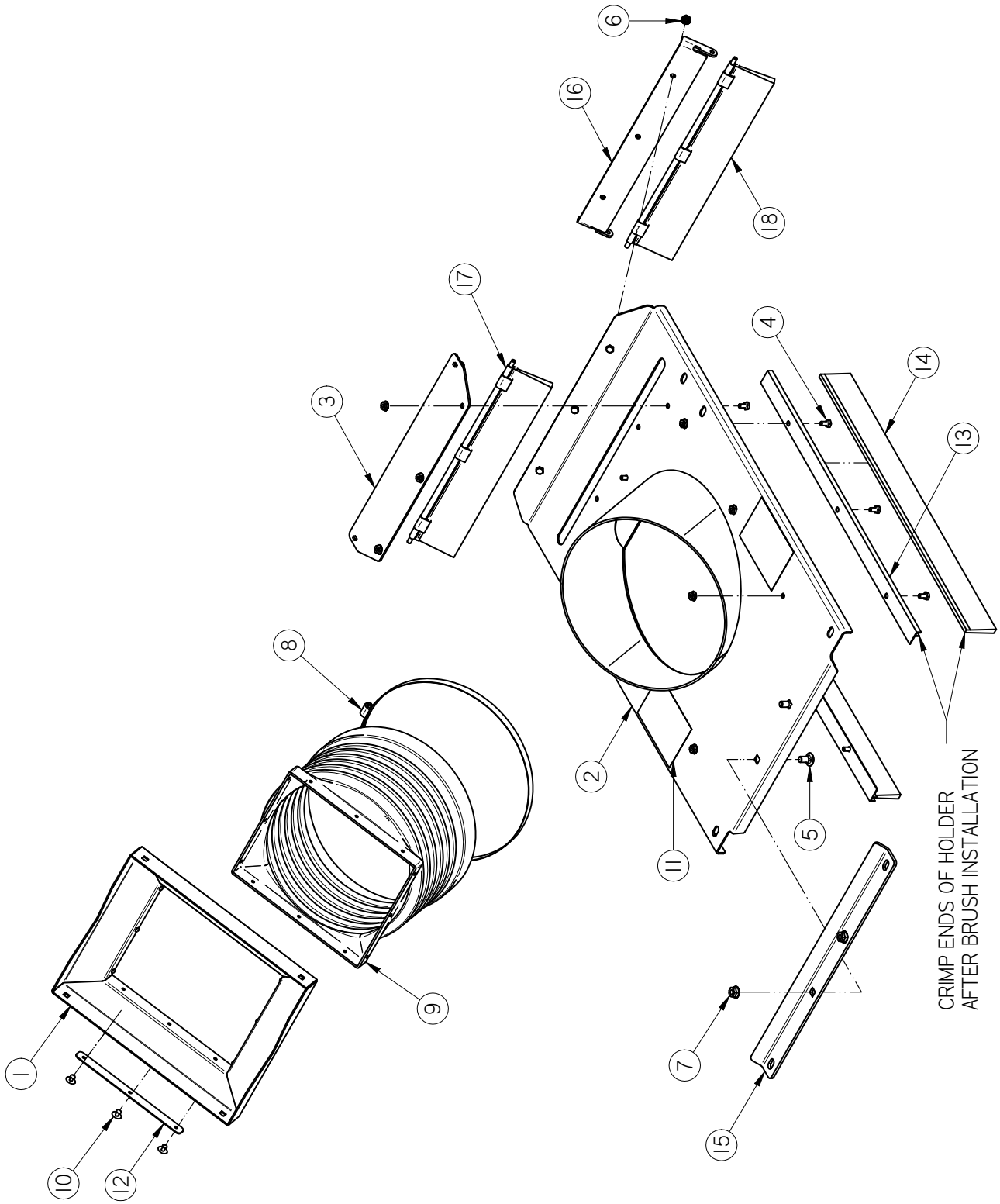

SEED SERIES 16 CONVEYOR

INLET HOPPER - ROUND (13-08-0421)

Item #	Part #	Description	Qty
1	05-08-0313	WDMT TRANS TRTR DSCHG	1
2	05-08-0367	WDMT INLET HOPP RND SS16	1
3	05-08-0537	WDMT PIVOT BRSH PLT TS35	1
4	06-01-0004	BOLT, .250-20 X .500 UNC ZP GRADE 5	12
5	06-01-0153	BOLT CRG .375-16X.750 ZP SHORT NECK	2
6	06-03-0013	NUT,LOCK, FLG .250-20 ZP SERRATTED	12
7	06-03-0014	NUT LOCK FLG .375-16 ZP GR5	2
8	06-07-0032	CLMP HOSE QR 16.25 X 9/16 SS	1
9	06-10-0047	TRANSITION SPOUT FLEXIBLE	1
10	06-12-0022	RIVET POP .188 X .312 GRIP SS .65HD	12
11	09-02-0001	ATWK LBL DANGER FINGERS	2
12	102FB6	PLT CLMP TRANS SEAL	4
13	10328A	INLET HOPPER BRUSH HOLDER	2
14	10328B	BRUSH	2
15	103361	PLT STIFFENER SS16	1
16	104739	EAR BRUSH MNT	1
17	13-05-0480	ASSY BRUSH W\CLIPS 15.438	1
18	13-05-0481	ASSY BRUSH W\CLIPS 16.062	1

INLET HOPPER COLAPSABLE (13-08-0425)

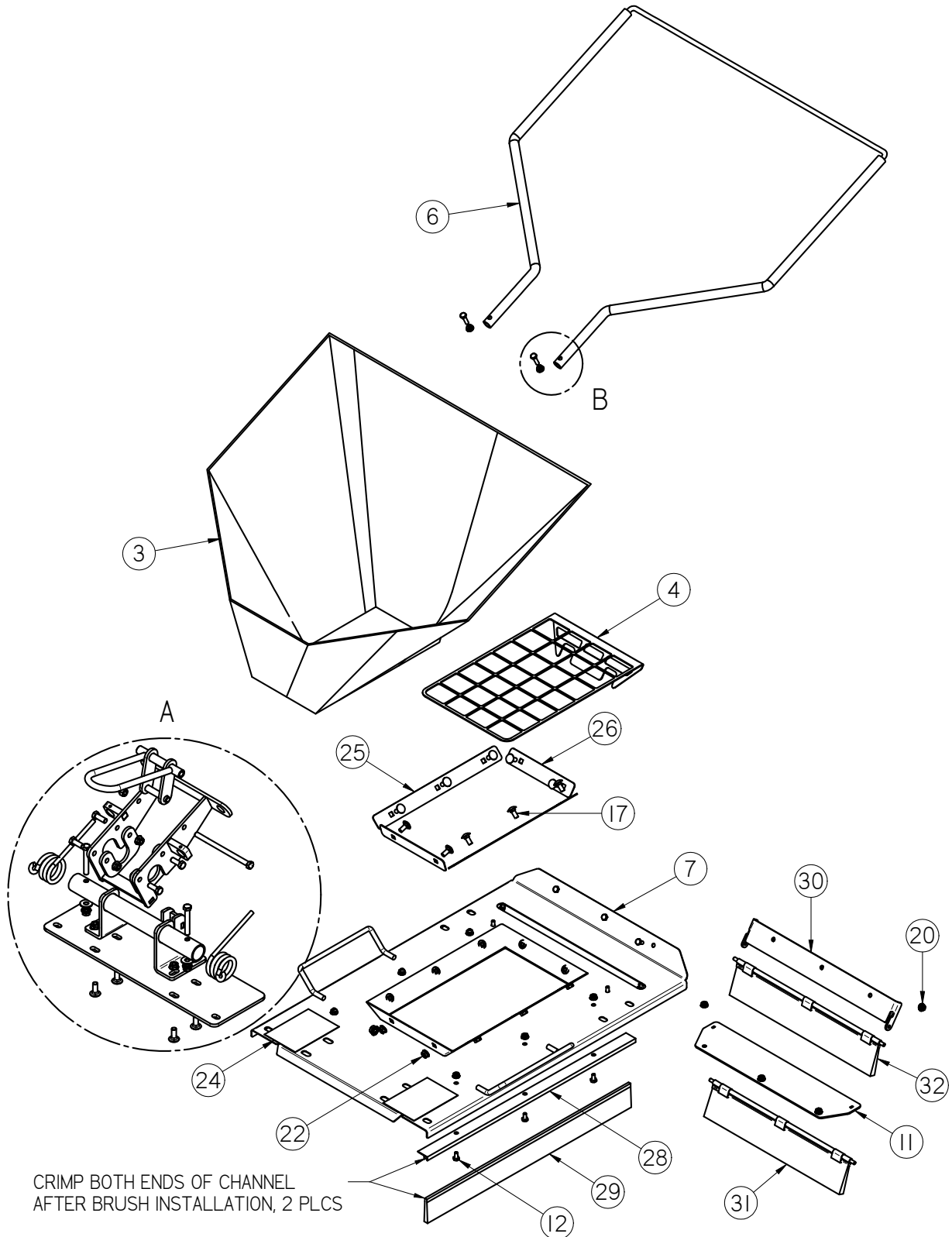

INLET HOPPER COLAPSABLE (13-08-0425)

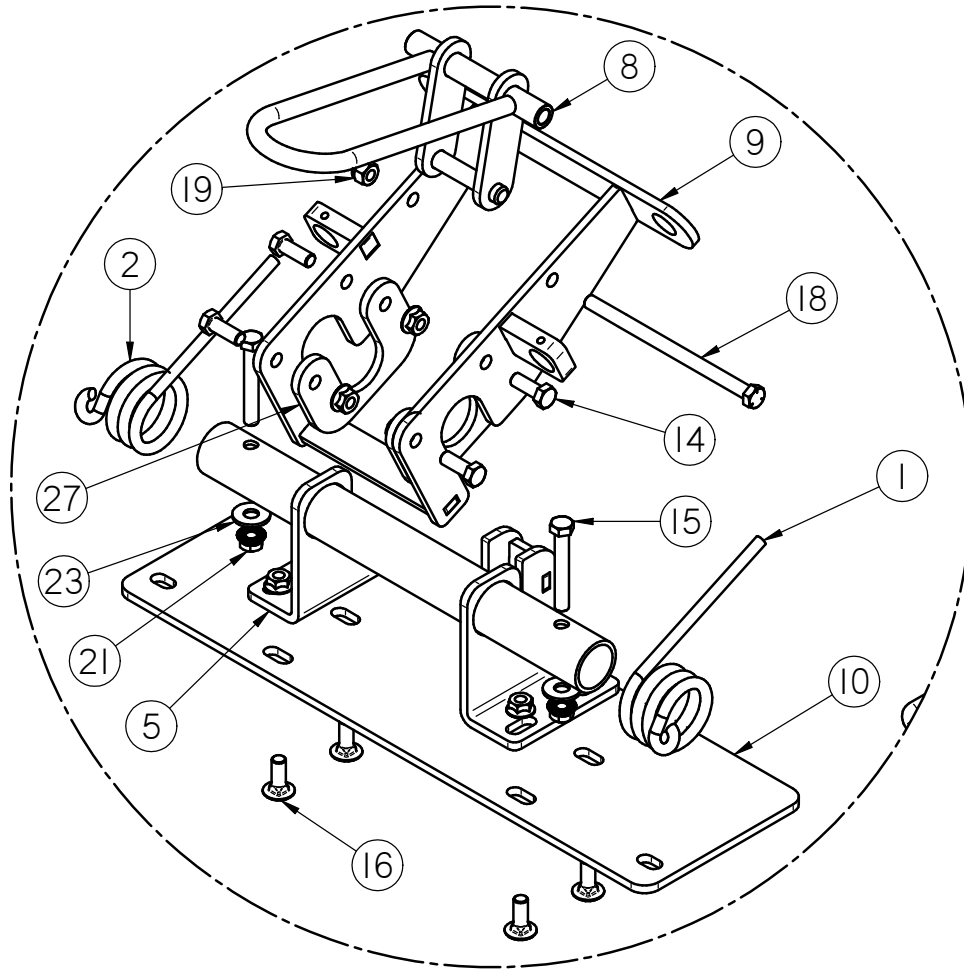

DETAIL A

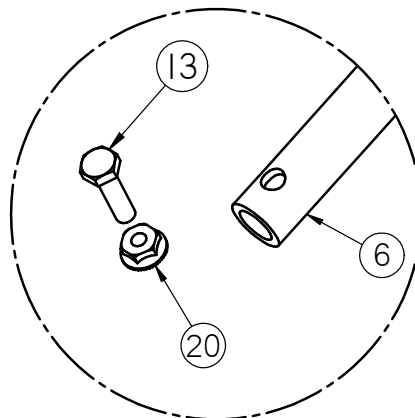

DETAIL B

SEED SERIES 16 CONVEYOR

INLET HOPPER COLAPSABLE (13-08-0425)

Item #	Part #	Description	Qty
1	01-04-0061	CLPSBL HOPP SPRING LH	1
2	01-04-0062	CLPSBL HOPP SPRING RH	1
3	01-13-0011	S2000 CLPSBL TARP	1
4	05-06-0095	S2000 CLPSBL HOPP GRATE	1
5	05-07-0579	WDMT S2000 CLPSBL PIVOT	1
6	05-07-0580	WDMT S2000 CLPCBL TOP FRM	1
7	05-07-0709	WDMT SS16 INLT HOPP-CVR CLPSBL	1
8	05-08-0258	WDMT LATCH HNDL CLPSBL	1
9	05-08-0260	WDMT SPRG ATT CLPSBL	1
10	05-08-0312	WDMT MNT CLPSBL S2000	1
11	05-08-0537	WDMT PIVOT BRSH PLT TS35	1
12	06-01-0004	BOLT, .250-20 X .500 UNC ZP GRADE 5	12
13	06-01-0007	BOLT, .250-20 X 1 UNC ZP GRADE 5	2
14	06-01-0016	BOLT .375-16 X 1.00 ZP GR5	4
15	06-01-0071	BOLT .375-16 X 2.50 ZP GR5	2
16	06-01-0115	BOLT CRG .375-16 X 1.00 ZP GR5	4
17	06-01-0171	BOLT CRG .3125-18X.750 ZP SHORT NECK	10
18	06-01-0264	BOLT .375-16 X 6.00 ZP GR5	1
19	06-03-0003	NUT NYL LOCK .375-16 ZP GR5	1
20	06-03-0013	NUT,LOCK, FLG .250-20 ZP SERRATTED	14
21	06-03-0014	NUT LOCK FLG .375-16 ZP GR5	10
22	06-03-0019	NUT LOCK FLG .3125-18 ZP GR5	10
23	06-05-0004	WSHR FLAT .375 ZP	2
24	09-02-0001	ATWK LBL DANGER FINGERS	2
25	1027DC	S2000 CLPSBL TARP RET SIDE	2
26	1027DD	S2000 CLPSBL TARP RET FNT	2
27	102A30	PLT LATCH LOCK	2
28	10328A	INLET HOPPER BRUSH HOLDER	2
29	10328B	BRUSH	2
30	104739	EAR BRUSH MNT	1
31	13-05-0480	ASSY BRUSH W\CLIPS 15.438	1
32	13-05-0481	ASSY BRUSH W\CLIPS 16.062	1

LIMITED WARRANTY

SECTION J

USC, LLC, (Manufacturer) warrants its seed treating equipment as follows:

1. **Limited Warranty:** Manufacturer warrants that the Products sold hereunder will be free from defects in material and workmanship for a period of 18 months from date of shipment. If the Products do not conform to this Limited Warranty during the warranty period, Buyer shall notify Manufacturer in writing of the claimed defects and demonstrate to Manufacturer satisfaction that said defects are covered by this Limited Warranty. If the defects are properly reported to Manufacturer within the warranty period, and the defects are of such type and nature as to be covered by this warranty, Manufacturer shall, at its expense, furnish replacement Products or, at Manufacturer's option, replacement parts for the defective products. Shipping and installation of the replacement Products or replacement parts shall be at the Buyer's expense.

2. **Other Limits:** THE FOREGOING IS IN LIEU OF ALL OTHER WARRANTIES, EXPRESSED OR IMPLIED, INCLUDING BUT NOT LIMITED TO THE IMPLIED WARRANTIES OF MERCHANTABILITY AND FITNESS FOR A PARTICULAR PURPOSE. Manufacturer does not warrant against damages or defects arising from improper installation (where installation is by persons other than Manufacturer), against defects in products or components not manufactured by Manufacturer, or against damages resulting from such non-Manufacturer made products or components. Manufacturer passes on to the Buyer the warranty it received (if any) from the maker of such non-Manufacturer made products or components. This warranty also does not apply to Products upon which repairs and / or modifications have been effected or attempted by persons other than pursuant to written authorization by Manufacturer. This includes any welding on equipment which could damage electrical components. Manufacturer does not warrant against casualties or damages resulting from misuse and / or abuse of Products, improper storage or handling, acts of nature, effects of weather, including effects of weather due to outside storage, accidents, or damages incurred during transportation by common carrier.

3. **Exclusive Obligation:** THIS WARRANTY IS EXCLUSIVE. The sole and exclusive obligation of Manufacturer shall be to repair or replace the defective Products in the manner and for the period provided above. Manufacturer shall not have any other obligation with respect to the Products or any part thereof, whether based on contract, tort, strict liability or otherwise. Under no circumstances, whether based on this Limited Warranty or otherwise, shall Manufacturer be liable for lost profits, lost revenue, lost sales (whether direct or indirect damages), incidental, special, punitive, indirect or consequential damages.

4. **Other Statements:** Manufacturer's employees or representatives' oral or other written statements do not constitute warranties, shall not be relied upon by Buyer, and are not a part of the contract for sale or this limited warranty.

5. **Return Policy:** Approval is required prior to returning goods to Manufacturer. A restocking fee will apply.

6. **Entire Obligation:** This Limited Warranty states the entire obligation of Manufacturer with respect to the Products. If any part of this Limited Warranty is determined to be void or illegal, the remainder shall remain in full force and effect.

US / Canada Non-Exclusive 2016

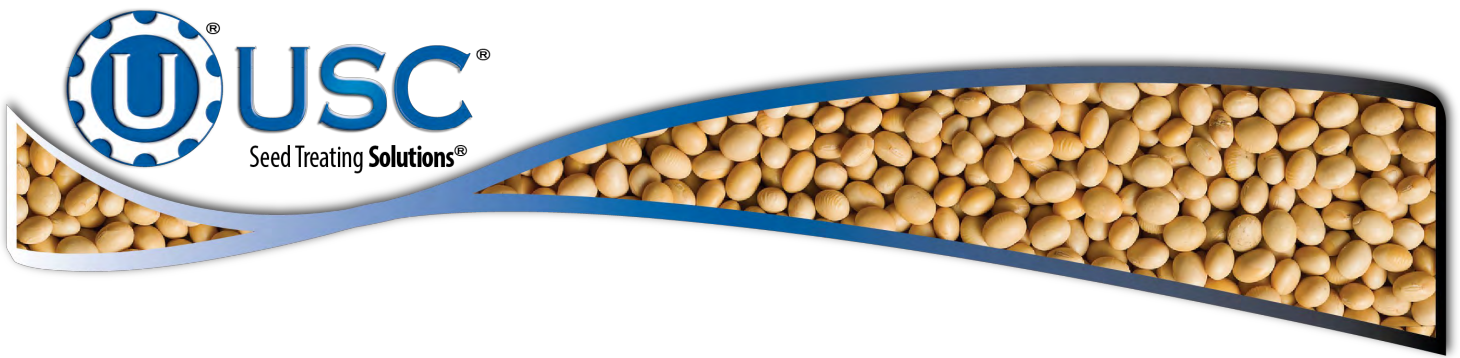

USC, LLC

2320 124th road

Sabetha, KS 66534

PHONE: (785) 431-7900

FAX: (785) 431-7950

EMAIL: sales-team@uscllc.com

WEB: www.uscllc.com

