



# SELF CONTAINED POLY UNIT



## *Operator's Manual*



# **INTRODUCTION**

Thank you for choosing USC, LLC for your equipment needs. We appreciate your business and will work diligently to ensure that you are satisfied with your choice.

## **OVERVIEW**

The purpose of this manual is to provide you with the basic information needed to operate and maintain the SC Poly Unit. It does not hold USC, LLC liable for any accidents or injuries that may occur.

## **OPERATOR RESPONSIBILITIES**

As the purchaser/owner/operator of this equipment and control system, you have an obligation to install, operate, and maintain the equipment in a manner that minimizes the exposure of people in your care to any potential hazards inherent in using this equipment. It is critical that the owner of this equipment:

- Has a clear and documented understanding of the process this machine is being used in and of any resulting hazards or special requirements arising from this specific application.
- Allow only properly trained and instructed personnel to install, operate, or service this equipment.
- Maintain a comprehensive safety program involving all who work with this machine and other associated process equipment.
- Establish clear areas of staff responsibility (e.g. operation, setup, sanitation, maintenance, and repairs).
- Provide all personnel with necessary safety equipment.
- Periodically inspect the equipment to insure that the doors, covers, guards, and safety devices are in place and functioning, that all safety instructions and warning labels are intact and legible, and that the equipment is in good working order.
- In addition to the operating instructions, observe and enforce the applicable legal and other binding regulations, national and local codes.

As the person with the most to gain or lose from working safely, it is important that you work responsibly and stay alert. By following a few simple rules, you can prevent an accident that could injure or kill you or a co-worker.

## SC POLY UNIT

- Do not operate, clean, or service this equipment until you have read and understood the contents of this manual. If you do not understand the information in this manual, bring it to the attention of your supervisor, or call your local USC dealer for assistance.
- Any operator who is known or suspected to be under the influence of alcohol or drugs should not be allowed to operate the equipment.
- Understand and follow the safety practices required by your employer and this manual.
- **PAY ATTENTION** to what you and other personnel are doing and how these activities may affect your safety.
- **Failure to follow these instructions may result in serious personal injury or death.**

### **RECEIVING YOUR EQUIPMENT**

As soon as the equipment is received, it should be carefully inspected to make certain that it has sustained no damage during shipment and that all items listed on the packing list are accounted for. If there is any damage or shortages, the purchaser must immediately notify your USC dealer. Ownership passes to purchaser when the unit leaves the USC, LLC. premises. The purchaser is responsible for unloading and mounting all components of the equipment.

Document the serial number of the machine for future reference. The serial number is located on the backside of the calibration valve bracket.



**SERIAL NUMBER:** \_\_\_\_\_

# TABLE OF CONTENTS

<u>Section</u>	<u>Contents</u>	<u>Page #</u>
Section A	Safety Instructions .....	5
Section B	Installation .....	12
Section C	<b>Mechanical Operation</b> .....	<b>14</b>
	System Overview .....	14
	Liquid System.....	15
Section D	<b>Electrical Operation</b> .....	<b>18</b>
	Diaphragm Pump Control Panel.....	18
	Peristaltic Pump Control Panel.....	20
Section E	<b>Calibration</b> .....	<b>22</b>
	Diaphragm Pump Calibration .....	22
	Peristaltic Pump Calibration .....	24
	Pump Charts .....	26
	Treating Seed.....	28
Section F	<b>Troubleshooting</b> .....	<b>29</b>
	Proximity Switch Adjustment Guide.....	30
Section G	<b>Maintenance</b> .....	<b>31</b>
Section H	<b>Storage</b> .....	<b>32</b>
Section I	<b>Mechanical Drawings</b> .....	<b>33</b>
Section J	<b>Limited Warranty</b> .....	<b>42</b>

# SAFETY INSTRUCTIONS

## SECTION A

Every year accidents in the work place maim, kill, and injure people. Although it may be impossible to prevent all accidents, with the right combination of training, operating practices, safety devices, and operator vigilance, the number of accidents can be significantly reduced. The purpose of this section is to educate equipment users about hazards, unsafe practices, and recommended hazard avoidance techniques.

### SAFETY WORDS AND SYMBOLS

It is very important that operators and maintenance personnel understand the words and symbols that are used to communicate safety information. Safety words, their meaning and format, have been standardized for U.S. manufacturers and published by the American National Standards Institute (ANSI). The European Community (E.C.) has adopted a different format based on the International Standards Organization (I.S.O.) and applicable machinery directives. Both formats are presented below. Graphic symbols are not standardized, but most manufacturers will use some variation of the ones seen in this manual.



Indicates an imminently hazardous situation which, if not avoided, **will** result in death or serious injury.



Indicates a potentially hazardous situation which, if not avoided, **could** result in death or serious injury.



Indicates a potentially hazardous situation which, if not avoided, **may** result in minor or moderate injury and/or property damage.



Provides additional information that the operator needs to be aware of to avoid a potentially hazardous situation.



**Mandatory Lockout Power Symbol.** Disconnect, lockout, and tagout electrical and other energy sources before inspecting, cleaning, or performing maintenance on this panel.



**International Safety Alert Symbol.** The exclamation point (!) surrounded by a yellow triangle indicates that an injury hazard exists. However, it does not indicate the seriousness of potential injury. The exclamation point (!) is also used with the DANGER, WARNING, and CAUTION symbols so the potential injury is indicated.



**Electrocution Hazard Symbol.** This symbol indicates that an electrocution hazard exists. Serious injury or death could result from contacting high voltage.



**International Electrocution Hazard.** This symbol indicates that an electrocution hazard exists. Serious injury or death could result from contacting high voltage.



**Mandatory Read Manual Action Symbol.** (I.S.O. format)  
This symbol instructs personnel to read the Operators Manual before servicing or operating the equipment.



**Mandatory Read Manual Action Symbol.** This symbol instructs personnel to read the Operators Manual before servicing or operating the equipment.

**NOTICE**

Notice is used to notify people of important installation, operation, or maintenance information which is not hazard related.

## **LOCKOUT / TAGOUT PROCEDURES**

Lockout/Tagout is the placement of a lock/tag on an energy isolating device in accordance with an established procedure. When taking equipment out of service to perform maintenance or repair work, always follow the lockout/tagout procedures as outlined in ANSI Z344.1 and/or OSHA Standard 1910.147. This standard “requires employers to establish a program and utilize procedures for affixing appropriate lockout devices or tagout devices to energy isolating devices and to otherwise disable machines or equipment to prevent unexpected energizing, start-up, or release of stored energy in order to prevent injury to employees.”

### **CONTROLLED STOP**

This is the stopping of machine motion by reducing the electrical command signal to 0 (zero) once the stop signal has been recognized.

### **HAZARD REVIEW**



#### **Electrocution Hazard**

Electrocution accidents are most likely to occur during maintenance of the electrical system or when working on or near exposed high voltage wiring.



This hazard does not exist when the electrical power has been disconnected, properly locked, and tagged out.



#### **Automatic Start Hazard**

This seed treating system is usually controlled by an automated system and may start without warning. Failure to properly disconnect, lockout, and tagout all energy sources of remotely controlled equipment creates a very hazardous situation and could cause injury or even death. PLEASE STAY CLEAR AND BE ALERT.





**YOU** are responsible for the **SAFE** operation and maintenance of your USC, LLC Seed Treating System. **YOU** must ensure that you and anyone else who is going to operate, maintain, or work around the Seed Treating System be familiar with the operating and maintenance procedures and related **SAFETY** information contained in this manual. This manual will take you step-by-step through your working day and alert you to good safety practices that should be adhered to while operating the Seed Treating System.

Remember, **YOU** are the key to safety. Good safety practices not only protect you, but also the people around you. Make these practices a working part of your safety program. Be certain that **EVERYONE** operating this equipment is familiar with the recommended operating and maintenance procedures and follows all the safety precautions. Most accidents can be prevented. Do not risk injury or death by ignoring good safety practices.

- SC Poly Unit owners must give operating instructions to operators or employees before allowing them to operate the machine, and at least annually thereafter per OSHA (Occupational Safety and Health Administration) regulation 1928.57.
- The most important safety device on this equipment is a **SAFE** operator. It is the operator's responsibility to read and understand **ALL** Safety and Operating instructions in the manual and to follow them. All accidents can be avoided.
- A person who has not read and understood all operating and safety instructions is not qualified to operate the machine. An untrained operator exposes himself and bystanders to possible serious injury or death.
- Do not modify the equipment in any way. Unauthorized modification may impair the function and/or safety and could affect the life of the equipment.
- Think SAFETY! Work SAFELY!

### GENERAL SAFETY

1. Read and understand the Operator's Manual and all safety signs before operating, maintaining, adjusting or unplugging the Dry Additive Feeder.
2. Only trained persons shall operate the seed treater. An untrained operator is not qualified to operate the machine.
3. Have a first-aid kit available for use should the need arise, and know how to use it.





## SC POLY UNIT

4. Provide a fire extinguisher for use in case of an accident. Store in a highly visible place.
5. Do not allow children, spectators or bystanders within hazard area of machine.
6. Wear appropriate protective gear. This includes but is not limited to:
  - A hard hat
  - Protective shoes with slip resistant soles
  - Protective goggles
  - Heavy gloves
  - Hearing protection
  - Respirator or filter mask
7. Place all controls in neutral or off, stop motor, and wait for all moving parts to stop. Then disable power source before servicing, adjusting, repairing, or unplugging.
8. Review safety related items annually with all personnel who will be operating or maintaining the SC Poly Unit.

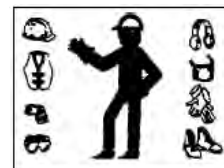

### **OPERATING SAFETY:**

1. Read and understand the Operator's Manual and all safety signs before using.
2. Disconnect and disable electrical supply completely and wait for all moving parts to stop before servicing, adjusting, repairing or unplugging.
3. Clear the area of bystanders, especially children, before starting.
4. Be familiar with the machine hazard area. If anyone enters hazard area, shut down machine immediately. Clear the area before restarting.
5. Keep hands, feet, hair and clothing away from all moving and/or rotating parts.
6. Stay away from overhead obstructions and power lines during operation and transporting. Electrocution can occur without direct contact.
7. Do not operate machine when any guards are removed.
8. Inspect welds and repair if needed.

### **PLACEMENT SAFETY**

1. Move only with the appropriate equipment
2. Be familiar with machine hazard area. If anyone enters hazard areas, shut down machine immediately. Clear the area before restarting.
3. Operate the SC Poly Unit on level ground free of debris.



Before placement of the SC Poly Unit, be sure the ground is reasonably level. The machine may topple or work improperly if the ground is too uneven, damaging the equipment and/or causing personal injury.

### **MAINTENANCE SAFETY**

1. Review the Operator's Manual and all safety items before working with, maintaining or operating the Seed Treating System.
2. Place all controls in neutral or off, stop motors, disable power source, and wait for all moving parts to stop before servicing, adjusting, repairing or unplugging.
3. Follow good shop practices:

Keep service area clean and dry.

Be sure electrical outlets and tools are properly grounded.

Use adequate light for the job at hand.

4. Keep hands, feet, hair and clothing away from all moving and/or rotating parts.
5. Clear the area of bystanders, especially children, when carrying out any maintenance and repairs or making any adjustments.
6. Before resuming work, install and secure all guards when maintenance work is completed.
7. Keep safety signs clean. Replace any sign that is damaged or not clearly visible.



## **SAFETY SIGNS**

1. Keep safety signs clean and legible at all times.
2. Replace safety signs that are missing or have become illegible.
3. Replaced parts that displayed a safety sign should also display the current sign.
4. Safety signs are available from your Authorized Dealer.

### **How to Install Safety Signs:**

- Be sure that the installation area is clean and dry.
- Be sure temperature is above 50°F (10°C).
- Decide on the exact position before you remove the backing paper.
- Remove the smallest portion of the split backing paper.
- Align the sign over the specified area and carefully press the small portion with the exposed sticky backing in place.
- Slowly peel back the remaining paper and carefully smooth the remaining portion of the sign in place.
- Small air pockets can be pierced with a pin and smoothed out using the piece of sign backing paper.



Located on the USC equipment you will find safety labels. Always be sure to read and follow all directions on the labels.



SECTION  
B**INSTALLATION**

**HIGH VOLTAGE** ~ Always disconnect the power source before working on or near the control panel or lead wires.



**HIGH VOLTAGE** ~ Use insulated tools when making adjustments while the controls are under power.

**NOTICE**

Permanent installation may require additional electrical cords, liquid hose, and air lines, since each installation is unique.

**SET-UP**

The following steps outline the initial set-up of the SC Poly Unit:

1. Clear the area of bystanders, especially small children, before moving.
2. Place the SC Poly Unit in the desired position on a level surface.

**NOTICE**

USC highly recommends that the equipment be set up inside a building or any covered structure to protect the machine from weathering.

3. The control panel must be connected to a 120-volt single phase power source.
4. The SC Poly Unit can be installed in conjunction with a seed treater. This will allow the rotating drum to mix the seed treatment being applied to the seed.
5. Hook up any plumbing to the seed treater or auger. The fitting below can be hooked directly into an auger. This fitting can be removed to connect into any seed treater.

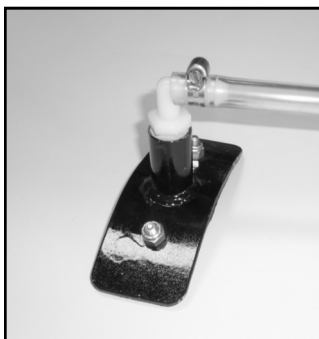

*Auger  
Hook-up*

SC POLY UNIT

5. Connect the 2-wire cord coming from the SC Poly Unit control panel to the auxiliary receptacle located on the bottom of the seed treater control panel. This will allow the operator to control the SC Poly Unit with the “Hand/Off/Auto” switch, located on the seed treater control panel.

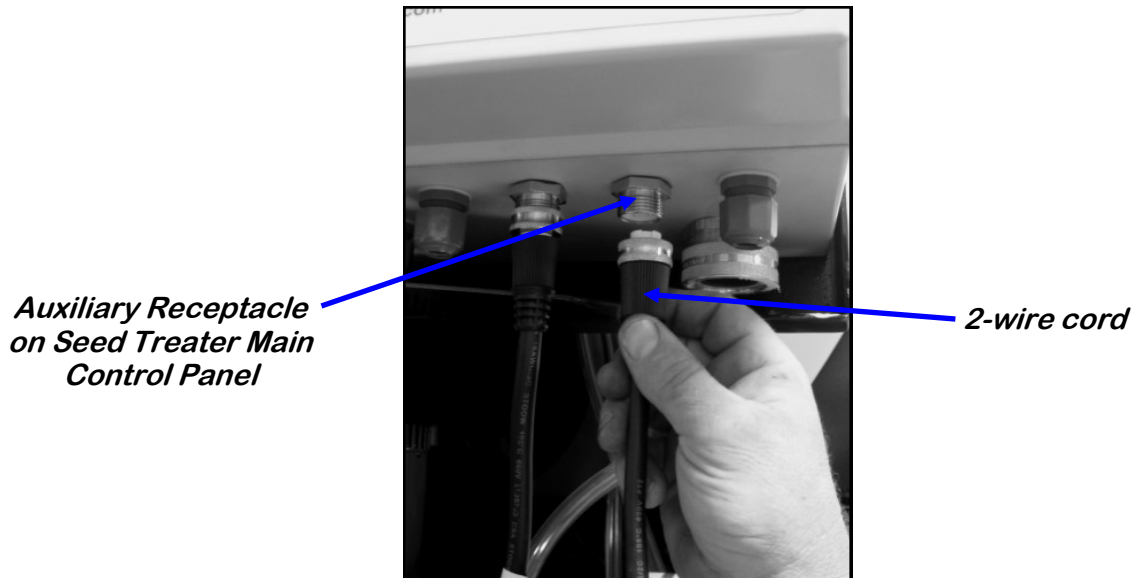

**NOTICE**

Some seed treaters may not be pre-wired with the auxiliary receptacle. Contact your local dealer for a kit to mount this receptacle in the seed treater control panel.

Part number: 03-12-0014.

**SECTION  
C**

**MECHANICAL OPERATION**

**SYSTEM OVERVIEW**

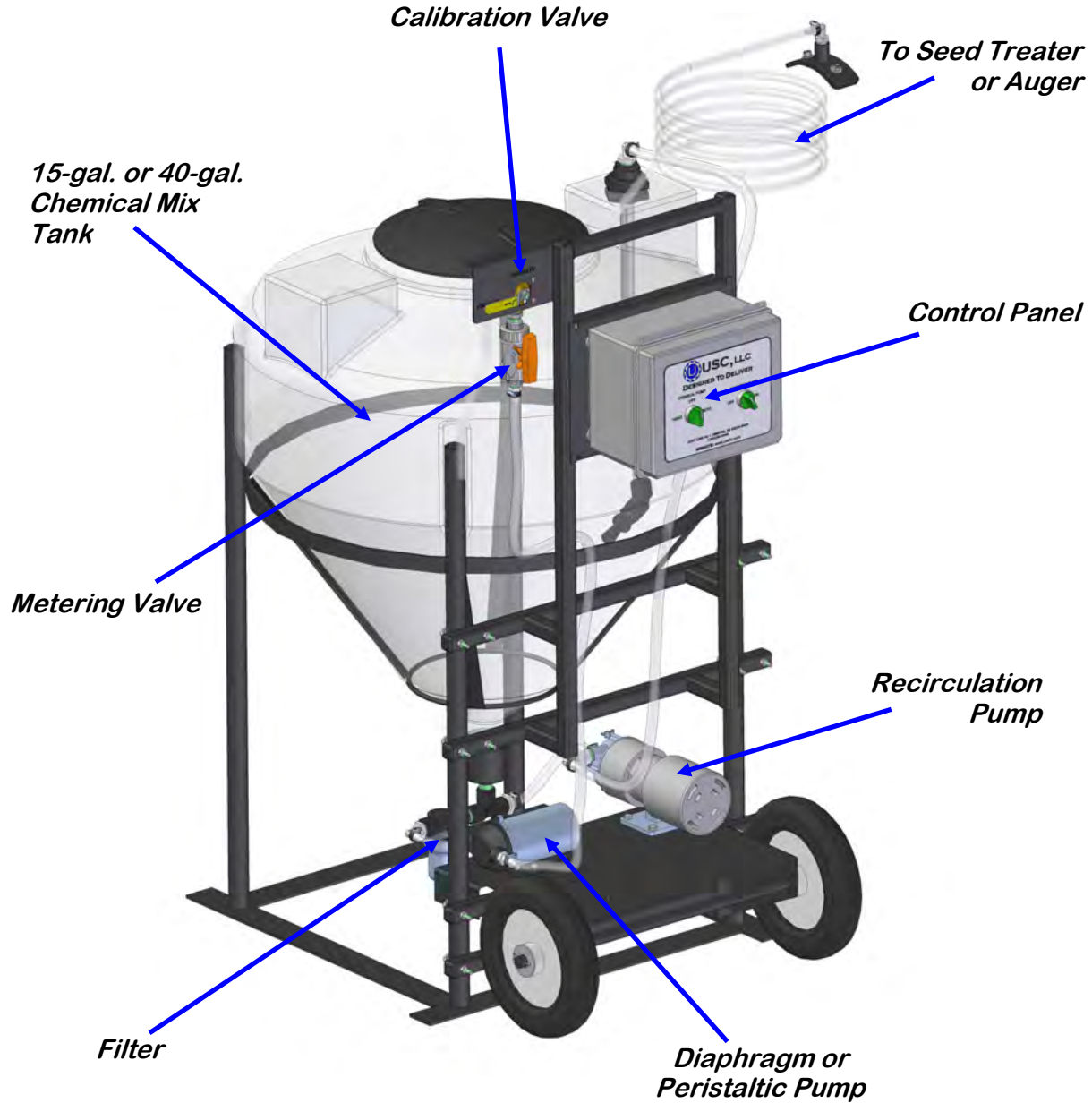

## **LIQUID SYSTEM**

The USC self Contained Poly Unit is equipped with either a 15 or 40 gallon mix tank with recirculation pump to keep chemicals mixed and in suspension. The pump should be used to keep chemical agitated. Do not run agitation pump continuously for a long period of time, as air can build up in the chemical and throw off the pump calibration. The tank is also equipped with an inline filter to prevent foreign objects from becoming lodged in the application pump.

The liquid system utilizes a diaphragm pump or a variable speed peristaltic pump for chemical metering. Both pumps are plumbed in-line with valves for easy calibration.

The diaphragm pumps use a metering valve to regulate the amount of liquid being applied. When storing the unit, flush the pump with water and drain it to prevent the pump from freezing or build-up of chemical residue.

The SC Poly Units that are supplied with a peristaltic pump, utilize a special control panel that regulates the speed of the pump and the direction. The pump also uses a special tubing that clamps inside a pumping head. To open the pump head, turn the lever to the left. Place pump tubing in pump head so it fits inside the notches and above the rollers. Turn lever back to the right to close the pump head, clamping the tubing inside the head. Wear or fatigue of the tubing due to usage and compression is normal. When tubing becomes worn or liquid rates begin to slow down, open the pump head and move the tubing to a different position. When the entire piece of tubing becomes worn, simply replace with a new section of tubing. When storing the seed treater, open the pump head and remove the tubing to prevent any extra compression during the off-season.



*Pump Head Open*



*Pump Head Closed*



Proper calibration of the pump is critical to achieve a proper granular/chemical mixture. The liquid pump is controlled by a variable speed motor. Controls for the peristaltic pump include a counting dial which controls the pump speed, a forward/brake/reverse switch which controls the pump direction, and a voltmeter that displays the amount of volts being sent to the pump. Rates should be determined in QTY/TIME. This will allow for proper liquid/granular mixtures.

Emptying the remaining chemical can be done by reversing the pump back into the mix tank and then draining the liquid into a suitable container. Clean water should be pumped through the calibration tube and mix tank when finished.



Always dispose of chemical or diluted chemical according to your local, state and federal regulations.



Only you, the operator, can determine the length of time required to completely rinse all chemical residue from the tank and plumbing system.

**NOTES**

A large, empty rectangular box with a black border, intended for handwritten notes.

SECTION  
D

# ELECTRICAL OPERATION

## MAIN CONTROL PANEL WITH DIAPHRAGM PUMP



**HIGH VOLTAGE** ~ Always disconnect the power source before working on or near the control panel or lead wires.



**HIGH VOLTAGE** ~ Use insulated tools when making adjustments while the controls are under power.



AUTHORIZED PERSONNEL only shall work on the control panel. Never allow anyone who has not read and familiarized themselves with the owner's manual to open or work on the control panel.

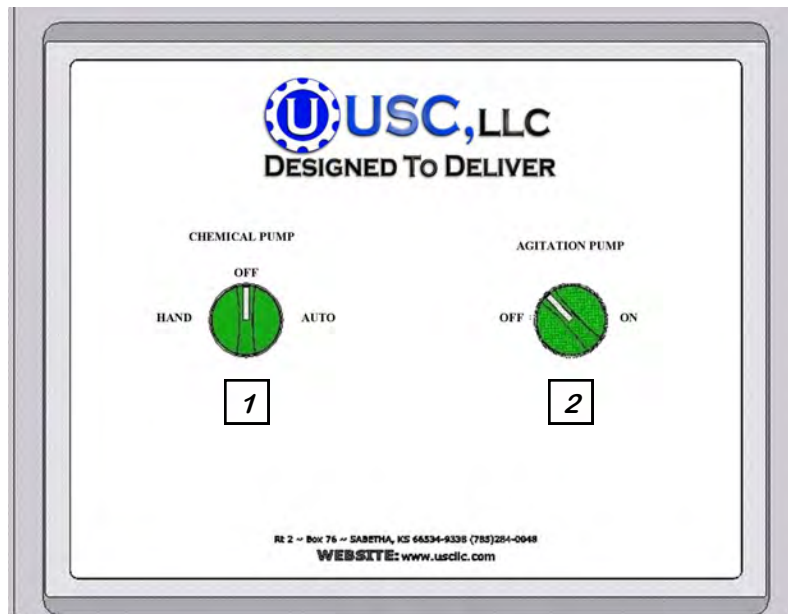

## Controls Explained

### 1. Chemical Pump Switch:

- When this switch is turned to “HAND”, the chemical pump will run.
- When the switch is turned to “AUTO”, the chemical pump will only run when the USC seed treater switch is turned to “HAND” or “AUTO”. The 2-wire cord must be connected to the seed treater before this feature will work. When the seed treater switch is turned to “HAND”, the chemical pump will run at any time. When turned to “AUTO”, it will only run when the proximity switch located in the bottom of the seed treater supply hopper is covered and the atomizer is running. The proximity switch determines when seed is present in the hopper. When the proximity switch does not detect seed, a timer relay located inside the control panel will automatically shut off the chemical pump a pre-determined amount of time after the hopper has emptied. The timer relay (right) located in the seed treater control panel is set to Mode “D” and has an adjustable knob with settings from 0-6. Each number represents the number of seconds from the time the hopper empties until the pump shuts off. The time delay allows all seed in the hopper to have an equal coverage.



2. Agitation Pump: This switch allows the operator to turn the chemical agitator pump on or off to allow for recirculation of the chemical in the mix tank.

**MAIN CONTROL PANEL WITH PERISTALTIC PUMP**



**HIGH VOLTAGE** ~ Always disconnect the power source before working on or near the control panel or lead wires.



**HIGH VOLTAGE** ~ Use insulated tools when making adjustments while the controls are under power.



AUTHORIZED PERSONNEL only shall work on the control panel. Never allow anyone who has not read and familiarized themselves with the owner's manual to open or work on the control panel.

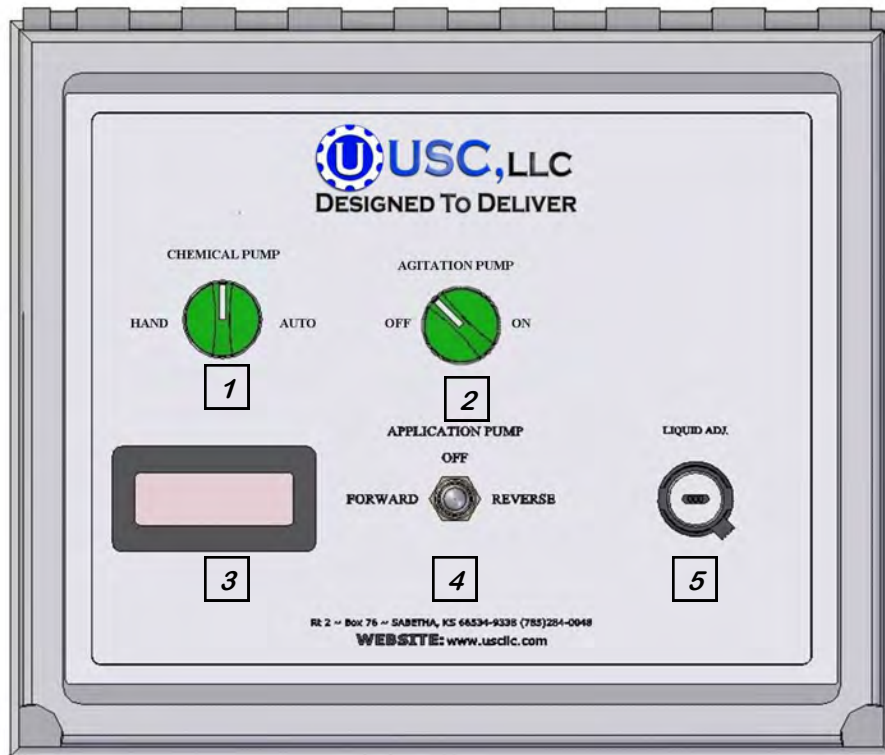

## **Controls Explained**

### **1. Chemical Pump Switch:**

- When this switch is turned to “HAND”, the chemical pump will run.
- When the switch is turned to “AUTO”, the chemical pump will only run when the USC seed treater switch is turned to “HAND” or “AUTO”. The 2-wire cord must be connected to the seed treater before this feature will work. When the seed treater switch is turned to “HAND”, the chemical pump will run at any time. When turned to “AUTO”, it will only run when the proximity switch located in the bottom of the seed treater supply hopper is covered and the atomizer is running. The proximity switch determines when seed is present in the hopper. When the proximity switch does not detect seed, a timer relay located inside the control panel will automatically shut off the chemical pump a pre-determined amount of time after the hopper has emptied. The timer relay (right) located in the seed treater control panel is set to Mode “D” and has an adjustable knob with settings from 0-6. Each number represents the number of seconds from the time the hopper empties until the pump shuts off. The time delay allows all seed in the hopper to have an equal coverage.



**2. Agitation Pump:** This switch allows the operator to turn the chemical agitator pump on or off to allow for recirculation of the chemical in the mix tank.

**3. Pump #1 Voltmeter:** Displays the DC voltage for pump #1. As pump #1 speed is increased or decreased, this number will also increase or decrease.

**4. Application Pump Direction:** This switch allows the operator to change the pump direction between forward and reverse. It has a safety feature that will not allow the operator to switch from forward to reverse or vice-versa without momentarily stopping and releasing the switch in the center position.

**5. Liquid Adjustment Dial:** This dial allows the operator to adjust the speed of the pump. The setting should be chosen in relation to the application rate for the treatment being applied to the seed.

SECTION  
E**CALIBRATION**

Calibration of both the seed flow and liquid portions of the equipment is necessary for accurate treatment of seed.

**NOTICE** If you prefer metric measurements, please refer to the conversion chart on page 27.

**DIAPHRAGM PUMP CALIBRATION**

The following steps illustrate how to calibrate a SC Poly Unit with a Diaphragm Pump. A stop watch and measuring cup will be needed in the calibration process.

1. Calibrate the seed flow of the seed treater before calibrating the SC Poly Unit. Seed flow calibrations should be done with at least 40 units or 2000 lbs of seed.
2. Premix enough liquid for the amount of seed you are treating and pour into the poly mixing tank. It's always a good practice to mix up 20% extra slurry to help fill all the lines.
3. Turn the Calibration valve to the "CALIBRATE" position.
4. Place the "CHEMICAL PUMP" switch in the "HAND" position.
5. Turn the "CHEMICAL PUMP" switch to "HAND", and adjust the Metering Valve to about "90". This will allow chemical to fill all the lines and pump. Use the measuring cup to catch the chemical as it empties out the end of the calibration hose.
6. Let chemical flow for at least 5 minutes to ensure all air has been removed from the liquid lines.
7. After you have ensured all air has been removed from the chemical lines. Turn the "Hand/Off/Auto" switch to "Off". Determine the number of ounces needed in one minute.

**EXAMPLE:** Seed Flow Rate = 7.00 cwt/min. x 4 oz. slurry/cwt. = 28 oz./min.  
28 oz. is the rate the pump should be flowing in one minute.



8. Set the Metering Valve. You can use the chart on page 26 to find a starting point.

**EXAMPLE:** The ounces needed in one minute = 28 oz/min.  
A good starting point is approximately dial setting 50 on the metering valve (right).

9. Use the stop watch and measuring cup to determine the pump flow rate. Position the Calibration valve to "CALIBRATE". Position the measuring cup under the calibration hose. Turn the "CHEMICAL PUMP" switch to "HAND" and begin timing for one minute as soon as liquid begins flowing into the measuring cup.

10. As soon as one minute is up, turn the "CHEMICAL PUMP" switch to "OFF". Read the level on the side of the measuring cup. This number should equal the number of ounces needed to flow through the pump in one minute. If the ounces needed per minute have not been met, adjust the Metering Valve up or down accordingly and repeat steps 9 & 10 until the liquid flow rate has been matched.



*Metering Valve at  
Dial Setting 50*

## PERISTALTIC PUMP CALIBRATION

The following steps illustrate how to calibrate a peristaltic pump on a SC Poly Unit. A stop watch and measuring cup will be needed in the calibration process.

1. Calibrate the seed flow of the seed treater before calibrating the SC Poly Unit. Seed flow calibrations should be done with at least 40 units or 2000 lbs of seed.
2. Lock down the pump tubing in the pump head. (page 15)
3. Premix enough liquid for the amount of seed you are treating and pour into the poly tank. It's always a good practice to mix up 20% extra slurry to help fill all the lines.
4. Turn the Calibration valve to the "CALIBRATE" position.
5. Turn the pump direction switch to "FORWARD".
6. Turn the "CHEMICAL PUMP" switch to the "HAND" position and set the Liquid Adjustment dial (right) to about "500" or half speed. Liquid should begin circulating from the bottom of the mix tank, through the pump, and out the calibration hose. Use the measuring cup or other container to catch the liquid.
7. Let chemical flow for at least 15 minutes to ensure all air has been removed from the liquid lines. This also helps to break-in the pump tubing, which is critical before checking liquid calibration.



**NOTICE** The break-in period can be done without pumping any liquid.

8. After you have allowed the liquid to circulate you are ready to calibrate the liquid flow. Turn the "CHEMICAL" switch to "OFF". Determine the number of ounces needed in one minute.

**EXAMPLE:** The seed treatment slurry rate is 4 ounces per cwt.  
 Seed Flow Rate = 7.00 cwt/min. x 4 oz./cwt. = 28 oz./min.  
 28.0 oz. is the rate the pump should be pumping in one minute.

9. Set the Liquid Adjustment Dial . You can use the chart on page 26 to find a starting point.

**EXAMPLE:** The ounces needed in one minute = 28 oz/min. Assume we are using a 6-600 Masterflex pump. A good starting point is approximately 34.8 volts.

10. Use the stop watch and measuring cup to determine the pump flow rate. Position the Calibration valve to "CALIBRATE". Position the measuring cup under the calibration hose. Turn the "CHEMICAL PUMP" switch to "HAND" and begin timing for one minute as soon as liquid begins flowing into the measuring cup.

**NOTICE** On some SC Poly Units, a Calibration Tube is used in place of the measuring cup and calibration hose.

11. As soon as one minute is up, turn the "CHEMICAL PUMP" switch to "OFF". Read the level on the side of the measuring cup. This number should equal the number of ounces needed to flow through the pump in one minute. If the ounces needed per minute have not been met, adjust the pump speed up or down accordingly and repeat steps 9 & 10 until the liquid flow rate has been matched.

## Standard Data

Below are three charts that show the potential volts and oz./min of three different pumps at different settings.

**NOTICE**

*All calibrations were done using water. Numbers are not exact; only use these numbers as a starting point or for troubleshooting.*

---

### Diphragm Pump with Metering Valve

<u>Dial Setting</u>	<u>OZ./Min</u>	<u>Dial Setting</u>	<u>OZ./Min.</u>
25	1.0	105	156.2
30	2.9	110	161.6
35	6.8	115	164.6
40	11.6	120	167.0
45	18.0	125	168.1
50	28.2	130	170.3
55	37.7	135	172.0
60	51.8	140	174.2
65	68.1	145	175.0
70	84.5	150	175.5
75	99.1	155	176.5
80	113.2	160	177.1
85	128.7	165	177.5
90	139.1	170	178.0
95	147.0	175	179.0
100	152.0	180	179.5

---

### 6-600 Peristaltic Pump Masterflex L/S 35 Pump Hose

<u>Volts</u>	<u>OZ./Min.</u>
10.5	7.4
14.6	10.5
18.8	14.1
22.9	17.7
27.0	21.3
31.2	24.9
35.3	28.5
39.4	32.1
43.6	35.7
47.7	39.3
51.8	42.9
55.9	46.5
60.1	50.1
64.2	53.7
68.3	57.3
72.5	60.9
76.6	64.5
80.7	68.1
84.9	71.7
89.0	75.3

### 2-200 Peristaltic Pump Masterflex I/P 82 Pump Hose

<u>Volts</u>	<u>OZ./Min.</u>
10.0	12.7
14.1	19.3
18.2	25.8
22.3	32.4
26.3	39.0
30.4	45.5
34.5	52.1
38.6	58.7
42.7	65.2
46.8	71.8
50.8	78.4
54.9	84.9
59.0	91.5
63.1	98.1
67.2	104.7
71.3	111.2
75.3	117.8
79.4	124.4
83.5	130.9
87.6	137.5

## Metric Data

Below are three charts that show the potential volts and mil./min of three different pumps at different settings.

**NOTICE** *All calibrations were done using water. Numbers are not exact; only use these numbers as a starting point or for troubleshooting.*

---

### Diaphragm Pump with Metering Valve

<u>Dial Setting</u>	<u>ml/min.</u>	<u>Dial Setting</u>	<u>ml/min.</u>
25	30	105	4,620
30	86	110	4,780
35	201	115	4,869
40	343	120	4,940
45	532	125	4,972
50	834	130	5,037
55	1,115	135	5,088
60	1,532	140	5,153
65	2,014	145	5,177
70	2,500	150	5,191
75	2,931	155	5,221
80	3,348	160	5,239
85	3,807	165	5,250
90	4,115	170	5,265
95	4,348	175	5,295
100	4,496	180	5,310

---

### 6-600 Peristaltic Pump Masterflex L/S 35 Pump Hose

<u>Volts</u>	<u>ml/min.</u>
10.5	219
14.6	311
18.8	417
22.9	524
27.0	630
31.2	737
35.3	843
39.4	950
43.6	1,056
47.7	1,162
51.8	1,269
55.9	1,375
60.1	1,482
64.2	1,588
68.3	1,695
72.5	1,801
76.6	1,908
80.7	2,014
84.9	2,121
89.0	2,227

### 2-200 Peristaltic Pump Masterflex I/P 82 Pump Hose

<u>Volts</u>	<u>ml/min.</u>
10.0	376
14.1	570
18.2	764
22.3	959
26.3	1,153
30.4	1,347
34.5	1,541
38.6	1,736
42.7	1,930
46.8	2,124
50.8	2,318
54.9	2,513
59.0	2,707
63.1	2,901
67.2	3,096
71.3	3,290
75.3	3,484
79.4	3,678
83.5	3,873
87.6	4,067

### **TREATING SEED**

1. Turn the Calibration Valve to “PROCESS” and the “CHEMICAL PUMP” switch to “Hand” to prime the line to the seed treater. After the line has been primed, turn the switch on the panel to “Auto”.
2. Position all conveyors, hoppers, wagons, or boxes in place.
3. Turn all conveyor or seed treater switches to “ON”.
4. With all motors turned to the “ON” position, you are ready for seed.
5. Begin feeding seed into the seed treater. If you are using the “Auto” function, the proximity switch in the seed treater will start the pump automatically. If you are not using the “Auto” function, you will need to start the treatment as soon as seed lands in the seed treater.
6. When all seed has passed the proximity switch, the pump will automatically shut off if using the “Auto” function. If you are using the “Hand” function, you will need to shut the pump off manually.

#### **Conversion Chart**

**1 ounce = 29.58 milliliters**

**1 gallon = 3.79 liters**

**1 kilogram = 2.2 pounds**

**1 unit = 50 lbs or 22.73 kg**

**1 bushel = approx. 60 lbs or 27.27 kg**

**1 cwt = 100 lbs or 45.45 kg**

**TROUBLESHOOTING****SECTION  
F**

Below is a table describing the most frequent problems and solutions with the USC SC Poly Unit. For further assistance, contact your local USC dealer.

Problem	Possible Cause	Solution
Pump will not turn off in "AUTO" when seed runs out.	<ol style="list-style-type: none"> <li>1. Proximity switch is dirty.</li> <li>2. Proximity switch is too sensitive.</li> </ol>	<ol style="list-style-type: none"> <li>1. Clean proximity switch.</li> <li>2. Adjust proximity switch sensitivity by turning counter-clockwise.</li> </ol>
Pump will not turn on in "AUTO"	<ol style="list-style-type: none"> <li>1. Proximity switch is not covered.</li> <li>2. Atomizer is not on.</li> <li>3. Proximity switch is not sensitive enough.</li> </ol>	<ol style="list-style-type: none"> <li>1. Cover proximity switch.</li> <li>2. Turn on Atomizer.</li> <li>3. Adjust proximity switch clockwise to make more sensitive.</li> </ol>
Pump is Fluctuating	<ol style="list-style-type: none"> <li>1. Restriction in tubing.</li> <li>2. Tubing was not broken in properly before calibrating.</li> <li>3. DC Pump circuit board is going bad.</li> </ol>	<ol style="list-style-type: none"> <li>1. Flush tubing and check filter for any restrictions.</li> <li>2. Allow pump to recirculate for 15 minutes before checking calibration.</li> <li>3. Watch pump voltmeter for any fluctuations.</li> </ol>
Pump will not turn on	<ol style="list-style-type: none"> <li>1. Blown Fuse.</li> <li>2. Bad HP Resistor.</li> <li>3. Bad DC Pump Board.</li> </ol>	<ol style="list-style-type: none"> <li>1. Check fuses.</li> <li>2. Check HP Resistor.</li> <li>3. Change the DC Pump Board Part #: (03-01-0007).</li> </ol>
No Liquid is going to my treater	<ol style="list-style-type: none"> <li>1. Restriction in tubing.</li> <li>2. Seed Treatment valve is in Calibrate.</li> </ol>	<ol style="list-style-type: none"> <li>1. Flush tubing and check filter for any restrictions.</li> <li>2. Turn Seed Treatment valve to Process.</li> </ol>



## **PROXIMITY SWITCH ADJUSTMENT GUIDE**

The proximity switch located in the cone of the seed treater detects when seed is present. This will automatically shut off the SC Poly Unit when all seed has left the supply hopper.

Sometimes the proximity switch does not properly work. This can be caused from wear, dust, or even moisture. The first step is to clean the lens of the proximity switch. If this does not solve the problem, the next step would be to adjust the sensitivity of the proximity switch.

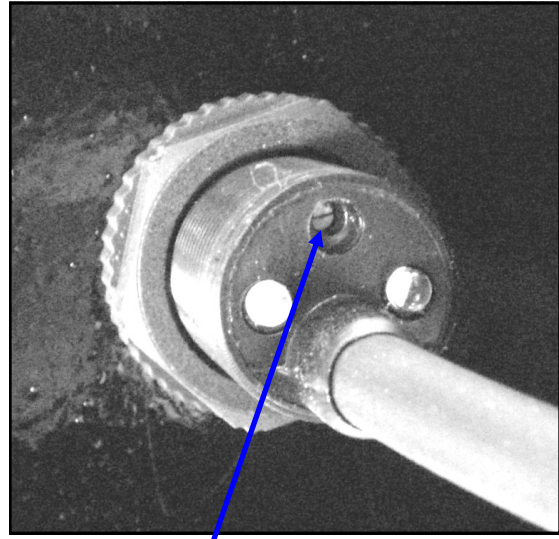

*Sensitivity Adjustment Screw*

Using the small screwdriver provided inside the control panel, you can adjust the proximity switch by turning the adjusting screw on the back of the proximity switch.

- Turn Clockwise to make the proximity switch more sensitive.
- Turn Counterclockwise to make the proximity switch less sensitive.



*Proximity Switch Screwdriver*

# MAINTENANCE

## SECTION G

Proper maintenance of the USC SC Poly Unit is critical for peak performance, reliability and accuracy of this system. The following is a guideline for the type of maintenance and servicing that should be performed on this unit. Your environment and uses may require additional maintenance and service beyond this list to assure a reliable and safe unit. The operator of this unit has ultimate responsibility to identify areas of concern and rectify them before they become a hazard or safety issue. There is no substitute for a trained, alert operator.



Do not put this unit into operation with any questionably maintained parts. Poor performance or a hazard may occur.

---

### MIX TANK

- Check agitation pump.
- Flush agitation pump with water and drain thoroughly.
- Check valves, fittings and plug on bottom of tank.

---

### PUMP AND PLUMBING

- Check pump in forward and reverse.
- Check pump voltage and inspect brushes in motors.
- Make sure pump head opens and closes smoothly.
- Inspect tubing and valves.
- Tighten hose clamps and check filter. Clean filter regularly to avoid build-up.

---

### CONTROL PANEL

- Check and tighten wire connections.
- Check starters and overloads.
- Check timers and relays.
- Check the front of the panel: switches, voltmeter, potentiometer, etc.
- Inspect fuses and breakers.
- Check and set the proximity switches.

**SECTION  
H****STORAGE**

When storing the USC SC Poly Unit for long periods of time, the following procedure must be followed to lessen the chance of rust, corrosion and fatigue.



Protective rubber gloves and protective eye wear shall be used when cleaning the machine

1. Make certain the inside of the tank is completely drained of chemical residue.
2. Thoroughly flush the inside of the tank with clean water.
3. Pump clean water through all areas of the plumbing including the mix tank, pumps, metering valve, and calibration valve.
4. Open all drain points and valves, and let as much of the liquid drain as possible.
5. If the unit will be exposed to possible freezing temperatures, the final flush of the system should be made with an anti-freeze liquid.
6. If the unit is supplied with a peristaltic pump, release the pump head and remove tubing to prevent any unnecessary wear.
7. Storing the machine inside a building is best to keep it from being exposed to the weather.
8. Disconnect power to the machine.

# MECHANICAL DRAWINGS

## SECTION I

The following pages show the parts of your SC Poly Unit. Please have the part number ready when ordering parts.

An electrical wiring diagram is located in the control panel of the self-contained unit at the time of shipment. The diagram located in the panel shows the exact electrical schematic for that model of self-contained unit. If you have any questions about the diagram, please call your local USC dealer.

**SC15MP - with Peristaltic Pump & Calibration Tube**

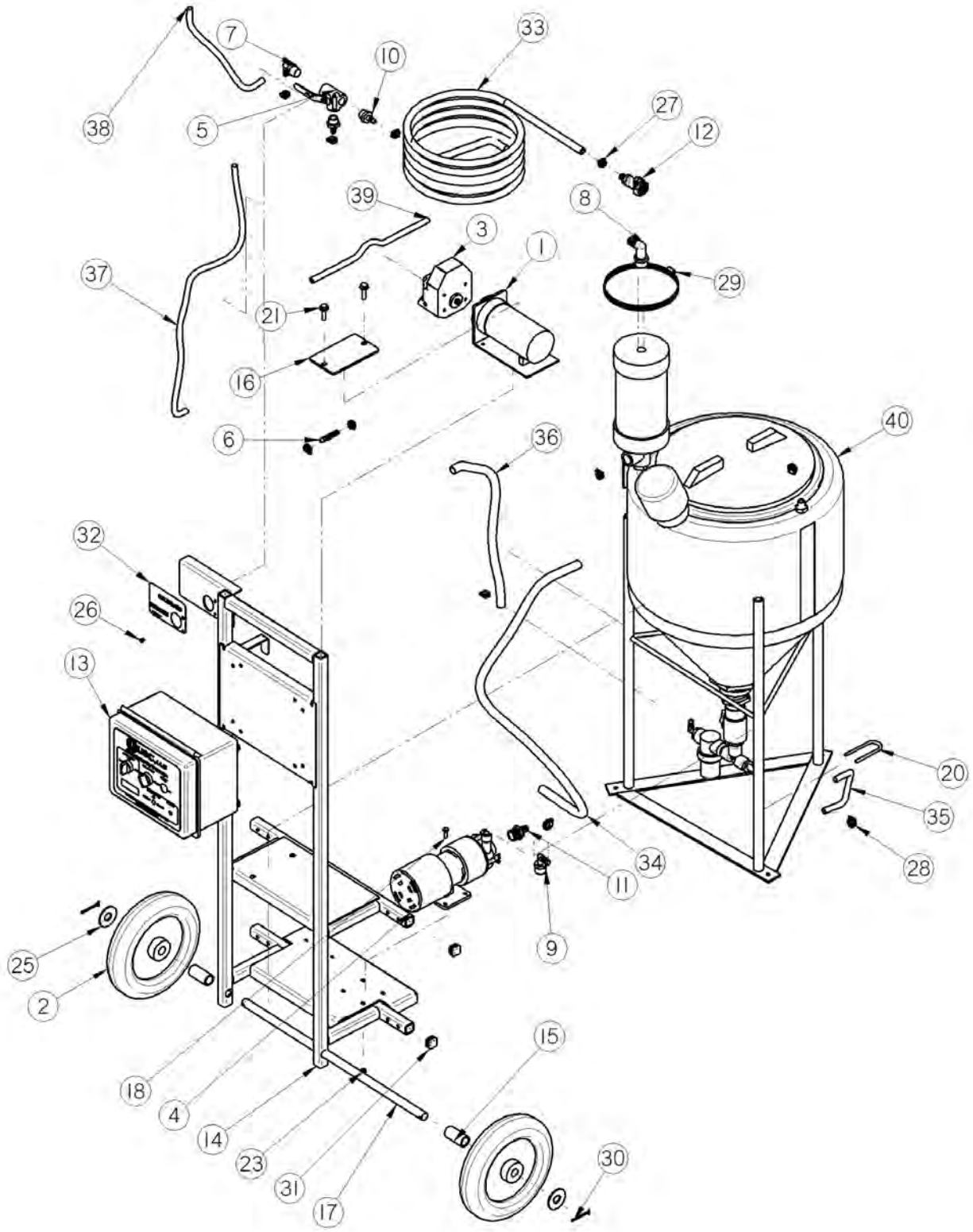

## SC POLY UNIT

**SC15MP - Parts List**

ITEM #	PART #	REV	TITLE	QTY
1	01-01-0010	A	MTR .1HP 6-600RPM 90VDC	1
2	01-06-0050	A	WHL 10 X 2.5 X .75ID RGD RBBR	2
3	02-01-0005	A	PUMP HEAD PRST MF LS 115V 600RPM	1
4	02-01-0023	A	CENR 4GPM 1740RPM (RECERC) 115V	1
5	02-02-0007	A	VLV BALL .500 NPT 3WAY BRSS	1
6	02-05-0002	A	FTTG CPLG .375 HB NYL	2
7	02-06-0006	A	FTTG 90 DEG .375HB X .500NPT ML NYL	1
8	02-06-0015	A	BARB, .750-14 NPT X .750 90DEG WP	1
9	02-06-0040	A	FTTG 90 DEG .500HB X .500NPT FM NYL	1
10	02-08-0005	A	1/2-14 NPT, 3/8 BARB, STRAIGHT WP	2
11	02-08-0008	A	FTTG STGHT .750-14, 500 HB	1
12	02-15-0025	A	FTTG CPLG .375 HB QCK DISC BODY	1
13	03-12-0130	A	PNL CNTL MNL ST SC -MOP PRST-RECIR 115V	1
14	05-03-0310	C	WDMT SC15 CNTL PNL-PUMP BRKT	1
15	05-08-0068	A	SLEEVE AXLE SPACER SC	2
16	5/10/3876	A	PLT SC PUMP CLMP	1
17	05-11-0128	A	AXLE SC .750 OD X 23.5IN LONG	1
18	06-01-0006	A	BOLT .250-20 X .750 ZP GR5	4
19*	06-01-0012	A	BOLT .313-18 X 1.00 ZP GR5	1
20	06-01-0152	A	BOLT U .25-20 X 1.125 X 3.188 L ZP	4
21	06-01-0189	A	BOLT, FLG .375-16 UNC ZP GRADE 5; 1-1/4" LG	2
22*	06-01-0215	A	SCRW MACH #14 X .750 SS PLASTITE	4
23	06-03-0001	A	NUT, LOCK, .250-20 ZP G5 NYLON INSERT	4
24*	06-03-0002	A	NUT NYL LOCK .313-18 ZP GR5	1
25	06-05-0007	A	WASHER, .750 FLAT ZP	2
26	06-06-0008	A	SCRW MACH 10-24 X .250 PHLP PHD ZP	2
27	06-07-0005	A	CLMP HOSE .219 TO .625 X .313W ZP	10
28	06-07-0006	A	CLMP HOSE .500 TO .906 X .313W ZP	4
29	06-07-0021	A	HOSE CLAMP, 4-1/8" to 7"	1
30	06-09-0018	A	.125 X 2.00 ZP COTTER PIN	2
31	06-10-0027	A	RIBBED POLYE 1X1 TBG PLUG	6
32	09-01-0127	A	LBL ATWK VLV SC	1
33	100927	A	100927	1
34	10092D	A	10092D	1
35	10092E	A	10092E	1
36	100A9F	A	100A9F	1
37	10135A	A	10135A	1
38	10135B	A	10135B	1
39	13-05-0018	A	100983	3
40	13-05-0181	A	ASSY 15 GAL CONE BTM W HI SPEED MX	1

**15 Gallon Cone Bottom Poly Tank Assembly with Hi Speed Mixer**

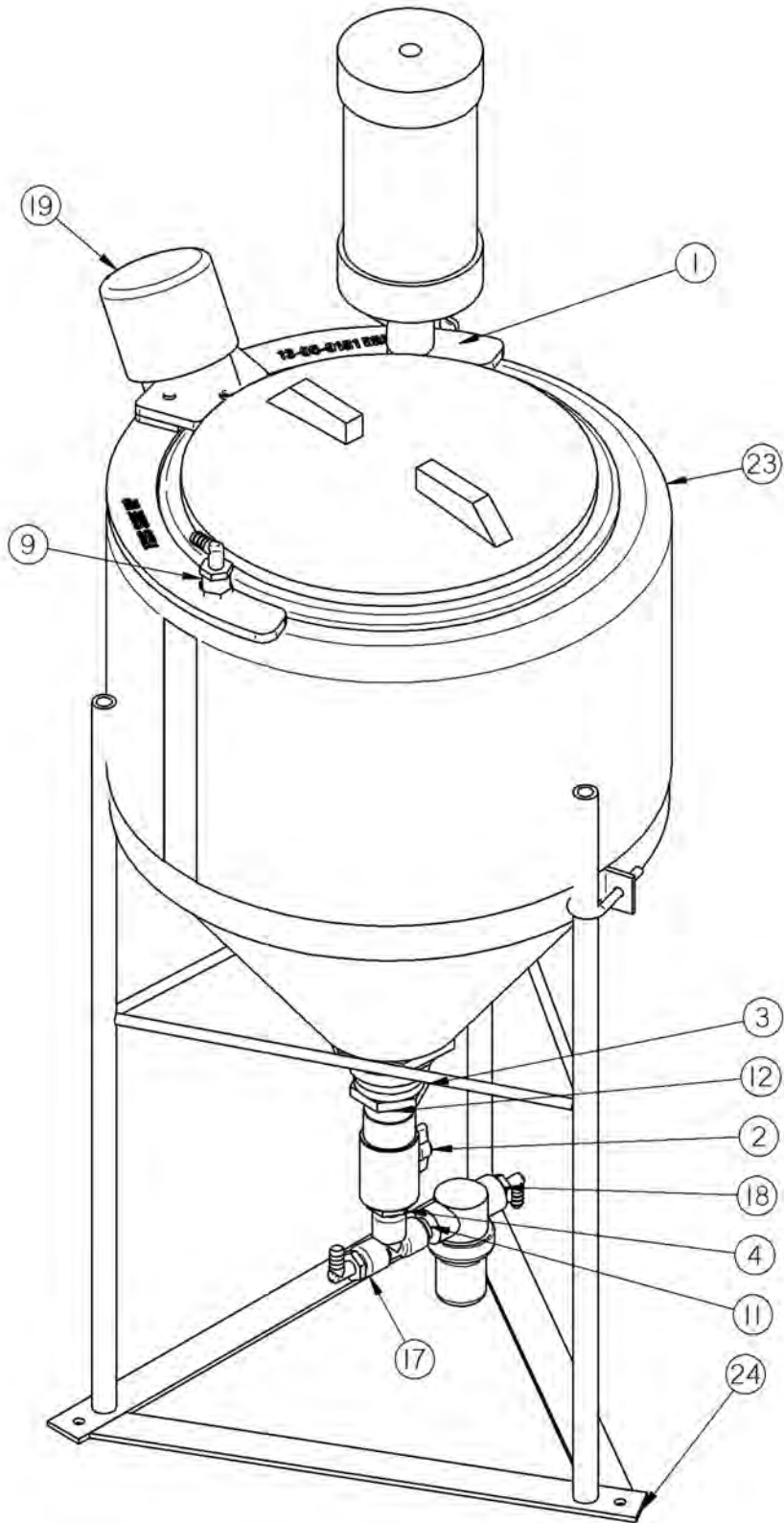



**15 Gallon Cone Bottom Poly Tank Assembly with Hi Speed Mixer**

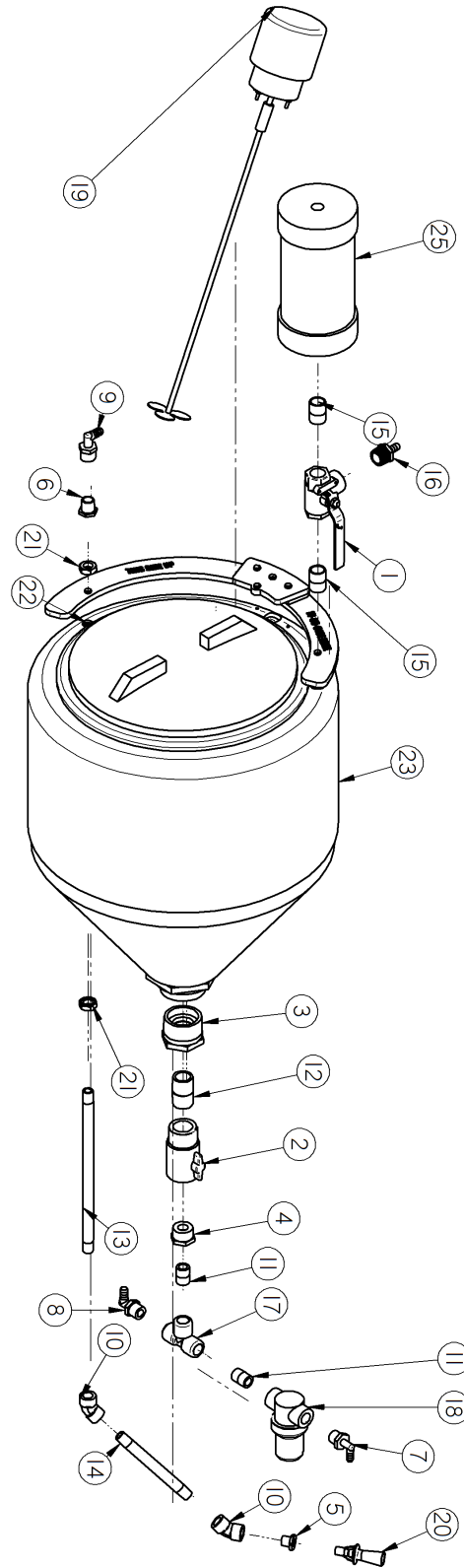

**15 Gallon Cone Bottom Poly Tank Assembly with Hi Speed Mixer - Parts List**

<u>Item #</u>	<u>Part #</u>	<u>Rev</u>	<u>Title</u>	<u>Qty</u>
1	02-02-0010	A	VLV BALL .750 NPT 3WAY BRSS	1
2	02-02-0048	A	VLV BALL 1.00 NPT FM PVC	1
3	02-04-0004	A	FTTG BUSH 2.00NPT X 1.00NPT NYL	1
4	02-04-0006	A	FTTG BUSH 1.00NPT X .500NPT PPE	1
5	02-04-0025	A	FTTG BUSH .375NPT X .250NPT PPE	1
6	02-04-0026	A	FTTG BUSH .500NPT X .375NPT NYL	1
7	02-06-0006	A	FTTG 90 DEG .375HB X .500NPT ML NYL	1
8	02-06-0010	A	FTTG 90 DEG .500HB X .500NPT ML NYL	1
9	02-06-0040	A	FTTG 90 DEG .500HB X .500NPT FM NYL	1
10	02-06-0046	A	FTTG 45 DEG .375NPT PVC	2
11	02-07-0054	A	FTTG NIP .500 NPT X 1.125 TBE G-PVC	2
12	02-07-0057	A	FTTG NIP 1.00 CLOSE BP	1
13	02-07-0061	A	FTTG NIP .375 NPT X 12.00 TBE PVC	1
14	02-07-0062	A	FTTG NIP .375 NPT X 6.00 TBE PVC	1
15	02-07-0071	A	FTTG NIP .75 NPT X 1.50 GALV SCH 40	2
16	02-08-0014	A	FTTG STGHT .375HB X .750NPT ML NYL	1
17	02-09-0005	A	FTTG TEE .500 NPT PPE	1
18	02-12-0002	A	FLTR TEE PPE .500 NPT 40 MESH LRG	1
19	04-03-0124	A	NEPTUNE L-1-BK MIXER	1
20	04-04-0008	A	NZL EDUCTOR PPE 46550-1/4-PP	1
21	06-03-0016	A	NUT LOCK .375 NPT PIPE	2
22	06-10-0010	A	O RING SIZE 114 VITON	1
23	07-02-0007	A	TNK 15GAL 60 DEG 2.00 NPT OUT	1
24	07-02-0015	A	FR 15GAL CONE BTM TNK	1
25	07-02-0018	A	CYL CALB LOOSE TOP 1300ML	1

SC POLY UNIT

**SC40 with Diaphragm Pump**

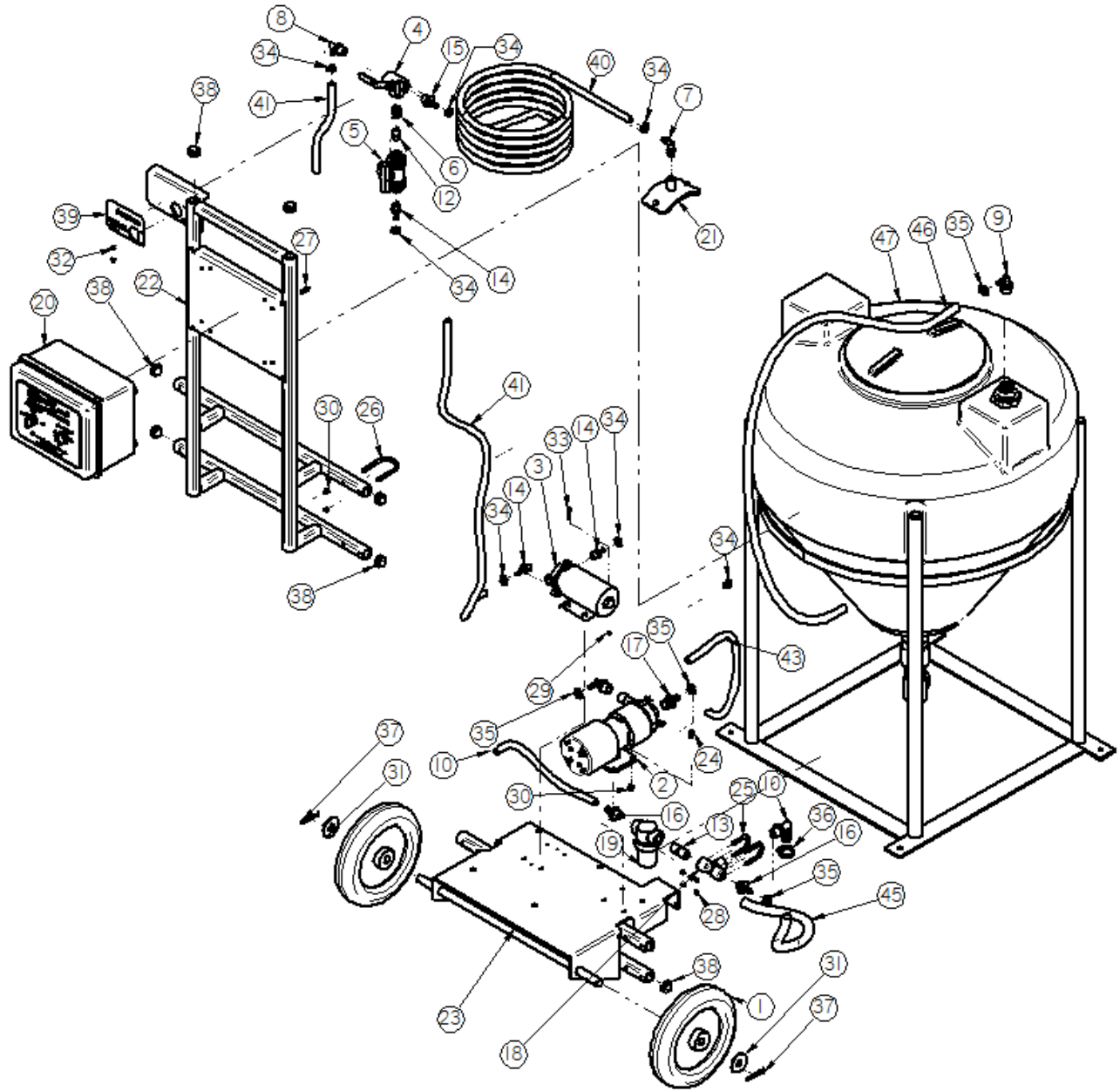

SC POLY UNIT

**SC40 with Diaphragm Pump - Parts List**

Item #	Doc #	Rev	Title	Qty
1	01-06-0050	A	WHL 10 X 2.5 X .75ID RGD RBBR	2
2	02-01-0023	A	CENR 4GPM 1740RPM (RECERC) 115V	1
3	02-01-0030	A	PUMP DPGM 1.4GPM 45PSI BYPASS 115V	1
4	02-02-0007	A	VLV BALL .500 NPT 3WAY BRSS	1
5*	02-02-0046	A	VLV DOUBLE UNION PPE BALL VALVE	1
6	02-05-0017		REDUCER .500NPT X .375 NPT 304SS	1
7	02-06-0005	A	3/8-18 NPT, 3/8 BARB, 90 DEG. WP	1
8	02-06-0006	A	FTTG 90 DEG .375HB X .500NPT ML NYL	1
9	02-06-0010	A	FTTG 90 DEG .500HB X .500NPT ML NYL	1
10	02-06-0014	A	1/2-14 NPT, 3/4 BARB, 90 DEG. WP	1
11*	02-06-0040	A	FTTG 90 DEG .500HB X .500NPT FM NYL	1
12	02-07-0001	A	NIPPLE, .375 NPT SCH. 40 304 SS	1
13	02-07-0009	A	FTTG NIP .500 NPT X 1.75 TBE BLK	1
14	02-08-0004	A	3/8-18 NPT, 3/8 BARB, STRAIGHT WP	3
15	02-08-0005	A	1/2-14 NPT, 3/8 BARB, STRAIGHT WP	1
16	02-08-0007	A	FTTG STGHT .500HB X .500NPT ML NYL	2
17	02-08-0008	A	FTTG STGHT .750-14,.500 HB	1
18	02-09-0005	A	FTTG TEE .500 NPT PPE	1
19	02-12-0002	A	FLTR TEE PPE .500 NPT 40 MESH LRG	1
20	03-12-0061	A	PNL CNTL MNL ST SC DPHG-RECIR 115V	1
21	04-01-0024	A	ASSY AUGER FEED TUBE ATMZR	1
22	05-03-0307	B	WDMT BOLT ON CNTL PNL BRKT	1
23	05-03-0308	C	WDMT PUMP AND AXLE MNT BRKT	1
24	06-01-0006	A	BOLT .250-20 X .750 ZP GR5	4
25	06-01-0120	A	U BOLT 1/4-20 1-1/8 INSIDE 2" LG	2
26	06-01-0151	A	U BOLT 1/4-20 1-1/8 INSIDE 2" LG	8
27	06-01-0215	A	SCRW MACH #14 X .750 SS PLASTITE	4
28	06-02-0001	A	NUT FULL .250-20 ZP GR5	4
29	06-02-0043	A	NUT,LOCK, #10-24 ZP NYLON INSERT	4
30	06-03-0001	A	NUT,LOCK, .250-20 ZP G5 NYLON INSERT	20
31	06-05-0007	A	WASHER, .750 FLAT ZP	2
32	06-06-0008	A	SCRW MACH 10-24 X .250 PHLP PHD ZP	2
33	06-06-0038	A	SRCW, PAN HD, 10-24 X 1.00 ZP	4
34	06-07-0005	A	CLMP HOSE .219 TO .625 X .313W ZP	7
35	06-07-0006	A	CLMP HOSE .500 TO .906 X .313W ZP	4
36	06-07-0008		HOSE CLAMP, #16 - 11/16" to 1-1/4"	2
37	06-09-0023	A	.188 X 2.00 ZP COTTER PIN	2
38	06-10-0027	A	RIBBED POLYE 1X1 TBG PLUG	10
39	09-01-0127	A	LBL ATWK VLV SC	1
40	100927	A	100927	1
41	100954	A	100954	1
42*	100955	A	100955	1
43	100A8F	A	100A8F	1
44*	100A90	A	100A90	1
45	100A91	A	100A91	1
46	100AA8	A	100AA8	1
47	13-05-0066	B	ASSY 40 GAL CONE BTM	1

SC POLY UNIT

**40 Gallon Cone Bottom Poly Tank Assembly & Parts List**

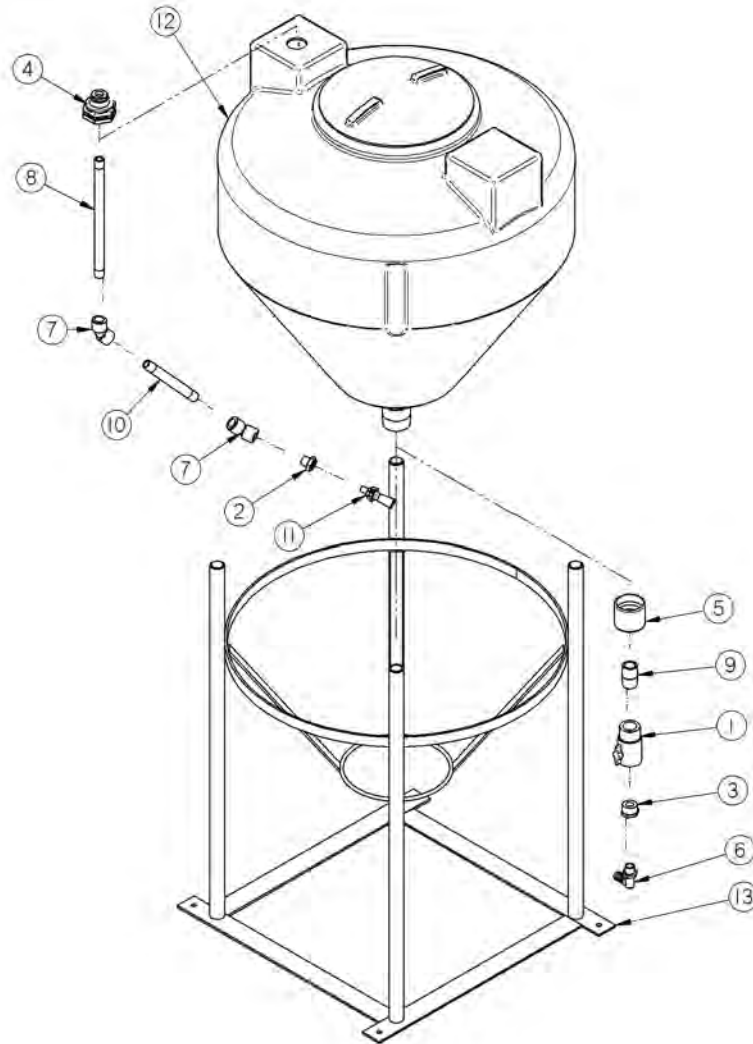

Item #	Part #	Rev	Title	Qty
1	02-02-0048	A	VLV BALL 1.00 NPT FM PVC	1
2	02-04-0001	A	1/2-14 NPT, REDUCER TO 1/4-18 NPT BP	1
3	02-04-0006	A	FTTG BUSH 1.00NPT X .500NPT PPE	1
4	02-05-0028	A	FTTG .500 NPT DBL THD PPE BULKHEAD	1
5	02-05-0039	A	REDUCER CPLG, 2.00NPT X 1.00 NPT	1
6	02-06-0014	A	1/2-14 NPT, 3/4 BARB, 90 DEG. WP	1
7	02-06-0045	A	FTTG 45 DEG .500NPT FM PPE BLK	2
8	02-07-0051	A	FTTG NIP .500 NPT X 12.00 TBE PVC	1
9	02-07-0057	A	FTTG NIP 1.00 CLOSE BP	1
10	02-07-0060	A	FTTG NIP .500 NPT X 6.00 TBE PVC	1
11	04-04-0008	A	NZL EDUCTOR PPE 46550-1/4-PP	1
12	07-02-0012	A	TNK 40GAL 60 DEG 2.00 MNPT FD	1
13	07-02-0014	A	TANK STAND 40/60 CONE BOTTOM	1

# LIMITED WARRANTY

## SECTION J

USC, LLC, (Manufacturer) warrants its seed treating equipment as follows:

1. **Limited Warranty:** Manufacturer warrants that the Products sold hereunder will be free from defects in material and workmanship for a period of 12 months from date of shipment. If the Products do not conform to this Limited Warranty during the warranty period, Buyer shall notify Manufacturer in writing of the claimed defects and demonstrate to Manufacturer satisfaction that said defects are covered by this Limited Warranty. If the defects are properly reported to Manufacturer within the warranty period, and the defects are of such type and nature as to be covered by this warranty, Manufacturer shall, at its expense, furnish replacement Products or, at Manufacturer's option, replacement parts for the defective products. Shipping and installation of the replacement Products or replacement parts shall be at the Buyer's expense.

2. **Other Limits:** THE FOREGOING IS IN LIEU OF ALL OTHER WARRANTIES, EXPRESSED OR IMPLIED, INCLUDING BUT NOT LIMITED TO THE IMPLIED WARRANTIES OF MERCHANTABILITY AND FITNESS FOR A PARTICULAR PURPOSE. Manufacturer does not warrant against damages or defects arising from improper installation (where installation is by persons other than Manufacturer), against defects in products or components not manufactured by Manufacturer, or against damages resulting from such non-Manufacturer made products or components. Manufacturer passes on to the Buyer the warranty it received (if any) from the maker of such non-Manufacturer made products or components. This warranty also does not apply to Products upon which repairs and/or modifications have been effected or attempted by persons other than pursuant to written authorization by Manufacturer. Manufacturer does not warrant against casualties or damages resulting from misuse and/or abuse of product(s), acts of nature, effects of weather, including effects of weather due to outside storage, accidents, or damages incurred during transportation by common carrier.

3. **Exclusive Obligation:** THIS WARRANTY IS EXCLUSIVE. The sole and exclusive obligation of Manufacturer shall be to repair or replace the defective Products in the manner and for the period provided above. Manufacturer shall not have any other obligation with respect to the Products or any part thereof, whether based on contract, tort, strict liability or otherwise. Under no circumstances, whether based on this Limited Warranty or otherwise, shall Manufacturer be liable for incidental, special, or consequential damages.

4. **Other Statements:** Manufacturer's employees or representatives' oral or other written statements do not constitute warranties, shall not be relied upon by Buyer, and are not a part of the contract for sale or this limited warranty.

5. **Return Policy:** Approval is required prior to returning goods to USC, LLC. A restocking fee will apply.

6. **Entire Obligation:** This Limited Warranty states the entire obligation of Manufacturer with respect to the Products. If any part of this Limited Warranty is determined to be void or illegal, the remainder shall remain in full force and effect.

**NOTES**

A large, empty rectangular box with a black border, intended for handwritten notes.



**USC, LLC**

2320 124th road

Sabetha, Ks 66534

PHONE: (785) 431-7900

FAX: (785) 431-7950

EMAIL: [sales-team@uscllc.com](mailto:sales-team@uscllc.com)

WEB: [www.uscllc.com](http://www.uscllc.com)

---